

SIEMENS



Motion Control Drives



# SINAMICS S210 Servo Drive System

Catalog  
D 32

Edition  
January  
2020

[siemens.com/drives](https://www.siemens.com/drives)

## Related catalogs

<p><b>Motion Control Drives</b> D 31.1 SINAMICS Inverters for Single-Axis Drives Built-In Units</p> <p>E86060-K5531-A111-A1-7600</p>		<p><b>Motion Control System</b> PM 21 SIMOTION Equipment for Production Machines</p> <p>E86060-K4921-A101-A4-7600</p>	
<p><b>Motion Control Drives</b> D 31.2 SINAMICS Inverters for Single-Axis Drives Distributed Inverters</p> <p>E86060-K5531-A121-A1-7600</p>		<p><b>Industrial Controls</b> IC 10 SIRIUS</p> <p>E86060-K1010-A101-B1-7600</p>	
<p><b>Motion Control Drives</b> D 31.5 SINAMICS Converters for Single-Axis Drives SINAMICS G120X infrastructure converters for HVAC/Water/Wastewater</p> <p>PDF (E86060-K5531-A151-A3-7600)</p>		<p><b>Industrial Controls</b> IC 10 AO SIRIUS Classic</p> <p>PDF (E86060-K1010-A191-A5-7600)</p>	
<p><b>SINAMICS S120</b> D 21.3 Chassis Format Converter Units Chassis-2 Format Converter Units Cabinet Modules, Cabinet Modules-2</p> <p><b>SINAMICS S150</b> Converter Cabinet Units E86060-K5521-A131-A7-7600</p>		<p><b>Low-Voltage Power Distribution and Electrical Installation Technology</b> LV 10 SENTRON • SIVACON • ALPHA Protection, Switching, Measuring and Monitoring Devices, Switchboards and Distribution Systems</p> <p>PDF (E86060-K8280-A101-B1-7600) Print (E86060-K8280-A101-A6-7600)</p>	
<p><b>Motion Control Drives</b> D 21.4 SINAMICS S120 and SIMOTICS</p> <p>E86060-K5521-A141-A1-7600</p>		<p><b>SIMATIC</b> ST 70 Products for Totally Integrated Automation</p> <p>PDF (E86060-K4670-A101-B7-7600)</p>	
<p><b>SIMOTICS S-1FG1</b> D 41 <b>Servo geared motors</b> Helical, Parallel shaft, Bevel and Helical worm geared motors</p> <p>PDF (E86060-K5541-A101-A4-7600)</p>		<p><b>SIMATIC HMI / PC-based Automation</b> ST 80/ST PC Human Machine Interface Systems PC-based Automation</p> <p>PDF (E86060-K4680-A101-C7-7600)</p>	
<p><b>SIMOTICS GP, SD, XP, DP</b> D 81.1 <b>Low-Voltage Motors</b> Type series 1FP1, 1LE1, 1LE5, 1MB1, 1MB5, 1PC1 Frame sizes 63 to 450 Power range 0.09 to 1000 kW PDF (E86060-K5581-A111-B4-7600)</p>		<p><b>Industrial Communication</b> IK PI SIMATIC NET</p> <p>E86060-K6710-A101-B8-7600</p>	
<p><b>FLENDER Couplings</b> MD 10.1 Standard Couplings</p> <p>E86060-K5710-A111-A5-7600</p>		<p><b>Products for Automation and Drives</b> CA 01 Interactive Catalog Download</p> <p><a href="http://www.siemens.com/automation/ca01">www.siemens.com/automation/ca01</a></p>	
<p><b>SIMOGEAR</b> D 50.1 <b>Geared Motors</b> Helical, parallel shaft, bevel, helical worm and worm geared motors</p> <p>E86060-K5250-A111-A6-7600</p>		<p><b>Industry Mall</b> Information and Ordering Platform on the Internet:</p> <p><a href="http://www.siemens.com/industrymall">www.siemens.com/industrymall</a></p>	

**SIEMENS**

# SINAMICS S210 Servo Drive System

Motion Control Drives

Catalog D 32 · January 2020

Dear Customer,

We are pleased to present you with the new Catalog D 32 · January 2020. This edition replaces Catalog D 32 · April 2019. The catalog provides a comprehensive overview of the new SINAMICS S210 servo drive system consisting of a SINAMICS S210 servo converter, a SIMOTICS S-1FK2 servomotor and a matching One Cable Connection (OCC).

The single-axis AC/AC servo converter system stands out due to its high performance and dynamic response for mid-range Motion Control applications. In addition to details of updates and technical modifications, the latest edition of the catalog has also been supplemented with the 400 V versions.

The products listed in this catalog are also included in the Industry Mall. Please contact your local Siemens office for additional information.

**NEW:** By clicking on the Article No. in the web PDF you can jump directly to the Industry Mall where you can obtain additional information and order products online.

Up-to-date information about SINAMICS S210 is available on the Internet at:

[www.siemens.com/sinamics-s210](http://www.siemens.com/sinamics-s210)

You can access our Interactive Catalog and Industry Mall online at:

[www.siemens.com/industrymall](http://www.siemens.com/industrymall)

Your personal contact will be happy to receive your suggestions and recommendations for improvement.

You can find your representative in our Personal Contact database at:

[www.siemens.com/automation-contact](http://www.siemens.com/automation-contact)

We hope that you will often enjoy using Catalog D 32 · January 2020 as a selection and ordering reference document and wish you every success with our products and solutions.

With kind regards,



Achim Peltz  
Vice President  
General Motion Control  
Siemens AG, Digital Industries, Motion Control



# SINAMICS S210 Servo Drive System

## Motion Control Drives



### Catalog D 32 · January 2020

Supersedes:  
Catalog D 32 · April 2019

Refer to the Industry Mall for current updates of  
this catalog:

[www.siemens.com/industrymall](http://www.siemens.com/industrymall)

The products contained in this catalog can also be found  
in the Interactive Catalog CA 01.

The Catalog CA 01 can be downloaded at:  
[www.siemens.com/automation/ca01](http://www.siemens.com/automation/ca01)

Please contact your local Siemens branch.

© Siemens 2020

Click on an Article No. in the catalog PDF to call it up in the  
Industry Mall and to obtain all the information.

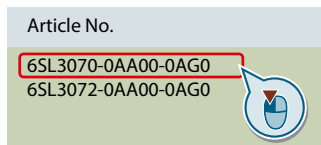

Or directly on the Internet, e.g.  
[www.siemens.com/product?6SL3070-0AA00-0AG0](http://www.siemens.com/product?6SL3070-0AA00-0AG0)



The products and systems described in  
this catalog are manufactured/distributed  
under application of a certified quality  
management system in accordance with  
DIN EN ISO 9001. The certificate is  
recognized by all IQNet countries.

## System overview

1

## SINAMICS S210 servo drive

2

## SIMOTICS S-1FK2 servomotors

3

## MOTION-CONNECT connection systems

4

## Engineering tools

5

## Services and documentation

6

## Appendix

7

# Digital Enterprise

## The building blocks that ensure everything works together perfectly in the digital enterprise

Digitalization is already changing all areas of life and existing business models. It is placing greater pressure on industry while at the same time creating new business opportunities. Today, thanks to scalable solutions from Siemens, companies can already become a digital enterprise and ensure their competitiveness.



### Industry faces tremendous challenges



#### Reduce time-to-market

Today manufacturers have to bring products to market at an ever-increasing pace despite the growing complexity of these products. In the past, a major manufacturer would push aside a small one, but now it is a fast manufacturer that overtakes a slow one.



#### Boost flexibility

Consumers want customized products, but at a price they would pay for a mass-produced item. That only works if production is more flexible than ever before.



#### Improve quality

To ensure a high level of quality while meeting legal requirements, companies have to establish closed quality loops and enable the traceability of products.

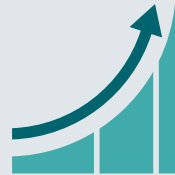

#### Boost efficiency

Today the product itself needs to be sustainable and environmentally friendly, while energy efficiency in production has become a competitive advantage.



#### Increase security

Increasing networking escalates the threat to production facilities of cyberattacks. Today more than ever, companies need suitable security measures.



## The digital enterprise has already become a reality

To fully benefit from all the advantages of digitalization, companies first have to achieve complete consistency of their data. Fully digitally integrated business processes, including those of suppliers, can help to create a digital representation of the entire value chain. This requires

- the integration of industrial software and automation,
- expansion of the communication networks,
- security in automation,
- and the use of business-specific industrial services.

## MindSphere

### The cloud-based open IoT operating system from Siemens

With MindSphere, Siemens offers a cost-effective and scalable cloud platform as a service (PaaS) for the development of applications. The platform, designed as an open operating system for the Internet of Things, makes it possible to improve the efficiency of plants by collecting and analyzing large volumes of production data.

### Totally Integrated Automation (TIA) Where digitalization becomes reality

Totally Integrated Automation (TIA) ensures the seamless transition from the virtual to the real world. It already encompasses all the necessary conditions for transforming the benefits of digitalization into true added value. The data that will form the digital twin for actual production is generated from a common base.

### Digital Plant

Learn more about the digital enterprise for the process industry  
[www.siemens.com/digitalplant](http://www.siemens.com/digitalplant)

### Digital Enterprise Suite

Learn more about the digital enterprise for the discrete industry  
[www.siemens.com/digital-enterprise-suite](http://www.siemens.com/digital-enterprise-suite)

# Integrated Drive Systems

Faster on the market and in the black with Integrated Drive Systems

Integrated Drive Systems are Siemens' trendsetting answer to the high degree of complexity that characterizes drive and automation technology today. The world's only true one-stop solution for entire drive systems is characterized in particular by its threefold integration: Horizontal, vertical, and lifecycle integration ensure that every drive system component fits seamlessly into the whole system, into any automation environment, and even into the entire lifecycle of a plant.

The outcome is an optimal workflow – from engineering all the way to service that entails more productivity, increased efficiency, and better availability. That's how Integrated Drive Systems reduce time to market and time to profit.

## Horizontal integration

**Integrated drive portfolio:** The core elements of a fully integrated drive portfolio are frequency converters, motors, couplings, and gear units. At Siemens, they're all available from a single source. Perfectly integrated, perfectly interacting. For all power and performance classes. As standard solutions or fully customized. No other player in the market can offer a comparable portfolio. Moreover, all Siemens drive components are perfectly matched, so they are optimally interacting.

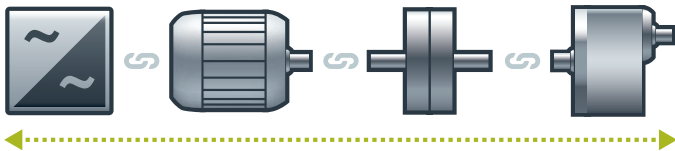

You can boost the availability of your application or plant to up to

**99%\***

\*e.g., conveyor application

## Vertical integration

Thanks to **vertical integration**, the complete drive train is seamlessly integrated in the entire automation environment – an important prerequisite for production with maximum value added. Integrated Drive Systems are part of Totally Integrated Automation (TIA), which means that they are perfectly embedded into the system architecture of the entire industrial production process. This enables optimal processes through maximum communication and control.

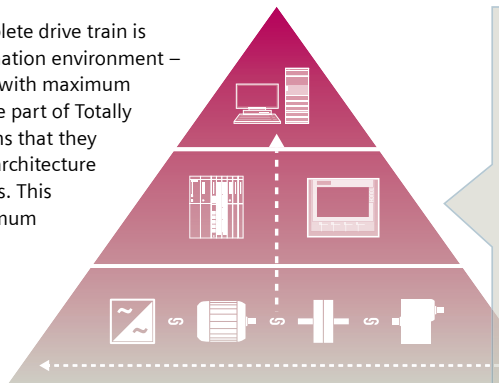

With TIA Portal you can cut your engineering time by up to

**30%**

## Lifecycle integration

**Lifecycle integration** adds the factor of time: Software and service are available for the entire lifecycle of an Integrated Drive System. That way, important optimization potential for maximum productivity, increased efficiency, and highest availability can be leveraged throughout the system's lifecycle – from planning, design, and engineering to operation, maintenance, and all the way even to modernization.

With Integrated Drive Systems, assets become important success factors. They ensure shorter time to market, maximum productivity and efficiency in operation, and shorter time to profit.

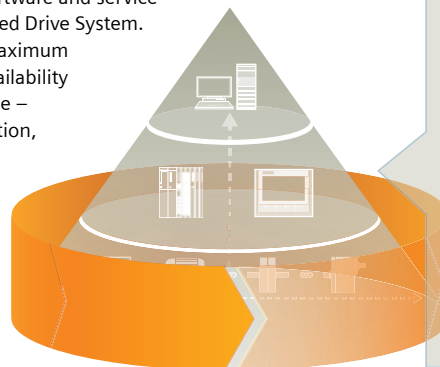

With Integrated Drive Systems you can reduce your maintenance costs by up to

**15%**



## System overview



1/2	<b>The SINAMICS converter family</b>
1/6	<b>Drive selection</b>
1/7	<b>SINAMICS S210 servo drive system</b>
1/13	Order overview
1/20	<b>SINAMICS S210 starter kit</b>

# System overview

## The SINAMICS converter family

### Overview

#### Integration in automation

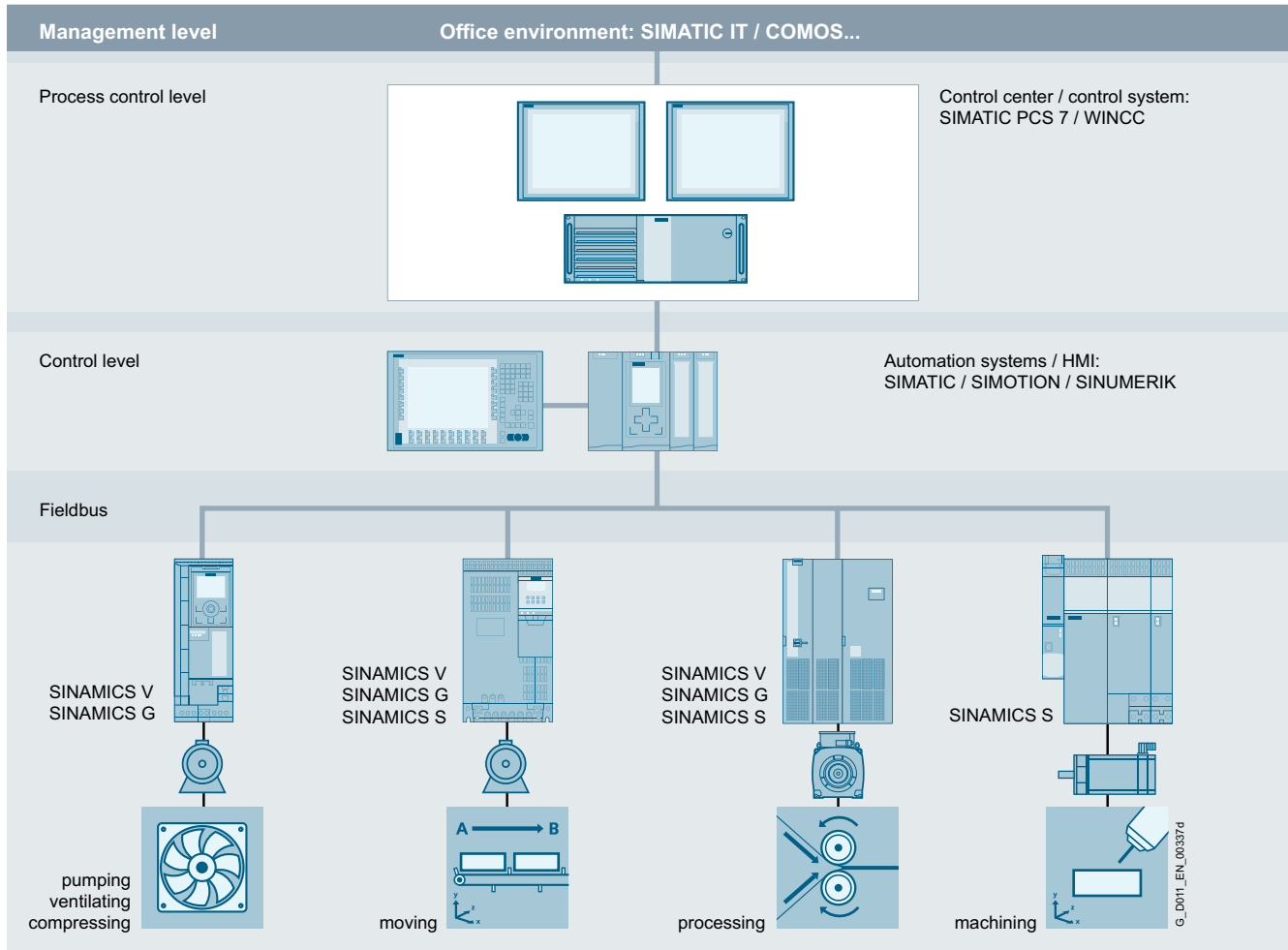

#### Totally Integrated Automation and communication

SINAMICS is an integral component of the Siemens "Totally Integrated Automation" concept. Integrated SINAMICS systems covering configuration, data storage, and communication at automation level ensure low-maintenance solutions with the SIMATIC, SIMOTION and SINUMERIK control systems.

Depending on the application, the appropriate variable frequency drives can be selected and incorporated in the automation concept. With this in mind, the drives are clearly subdivided into their different applications. A wide range of communication options (depending on the drive type) are available for establishing a communication link to the automation system:

- PROFINET
- PROFIBUS
- EtherNet/IP
- Modbus TCP
- Modbus RTU
- AS-Interface
- BACnet MS/TP

#### Applications

SINAMICS is the comprehensive converter family from Siemens designed for machine and plant engineering applications. SINAMICS offers solutions for all drive tasks:

- Simple pump and fan applications in the process industry
- Demanding single drives in centrifuges, presses, extruders, elevators, as well as conveyor and transport systems
- Drive line-ups in textile, plastic film, and paper machines as well as in rolling mill plants
- Highly dynamic servo drives for machine tools, as well as packaging and printing machines

## Overview

*SINAMICS as part of the Siemens modular automation system*



***Innovative, energy-efficient and reliable drive systems and applications as well as services for the entire drive train***

The solutions for drive technology place great emphasis on the highest productivity, energy efficiency and reliability for all torque ranges, performance and voltage classes.

Siemens offers not only the right innovative variable frequency drive for every drive application, but also a wide range of energy-efficient low-voltage motors, geared motors, explosion-protected motors and high-voltage motors for combination with SINAMICS.

Furthermore, Siemens supports its customers with global pre-sales and after-sales services, with over 295 service points in 130 countries – and with special services e.g. application consulting or motion control solutions.

***Energy efficiency***

Energy management process

Efficient energy management consultancy identifies the energy flows, determines the potential for making savings and implements them with focused activities.

Almost two thirds of the industrial power requirement is from electric motors. This makes it all the more important to use drive technology permitting energy consumption to be reduced effectively even in the configuration phase, and consequently to optimize plant availability and process stability. With SINAMICS, Siemens offers powerful energy efficient solutions which, depending on the application, enable a significant reduction in electricity costs.

G\_D011\_XX\_00515b

## System overview

### The SINAMICS converter family

#### Overview

##### Up to 70 % potential for savings using variable-speed operation

SINAMICS enables great potential for savings to be realized by controlling the motor speed. In particular, huge potential savings can be recovered from pumps, fans and compressors which are operated with mechanical throttle and valves. Here, changing to variable-speed drives brings enormous economic advantages. In contrast to mechanical control systems, the power consumption at partial load operation is always immediately adjusted to the demand at that time. So energy is no longer wasted, permitting savings of up to 60 % – in exceptional cases even up to 70 %. Variable-speed drives also offer clear advantages over mechanical control systems when it comes to maintenance and repair. Current spikes when starting up the motor and strong torque surges become things of the past – and the same goes for pressure waves in pipelines, cavitation or vibrations which cause sustainable damage to the plant. Smooth starting and ramp-down relieve the load on the mechanical system, ensuring a significantly longer service life of the entire drive train.

##### Regenerative feedback of braking energy

In conventional drive systems, the energy produced during braking is converted to heat using braking resistors. Energy produced during braking is efficiently recovered to the supply system by versions of SINAMICS G and SINAMICS S drives with regenerative feedback capability and these devices do not therefore need a braking resistor. This permits up to 60 % of the energy requirement to be saved, e.g. in lifting applications. Energy which can be reused at other locations on a machine. Furthermore, this reduced power loss simplifies the cooling of the system, enabling a more compact design.

##### Energy transparency in all configuration phases

Early on, in the configuration phase, the SIZER for Siemens Drives engineering tool provides information on the specific energy requirement. The energy consumption across the entire drive train is visualized and compared with different plant concepts.

##### SINAMICS in combination with energy-saving motors

Engineering integration stretches beyond the SINAMICS converter family to higher-level automation systems, and to a broad spectrum of energy-efficient motors with a wide range of performance classes, which, compared to previous motors, are able to demonstrate up to 10 % greater efficiency.

#### Variants

Depending on the application, the SINAMICS converter family offers the ideal variant for any drive task.

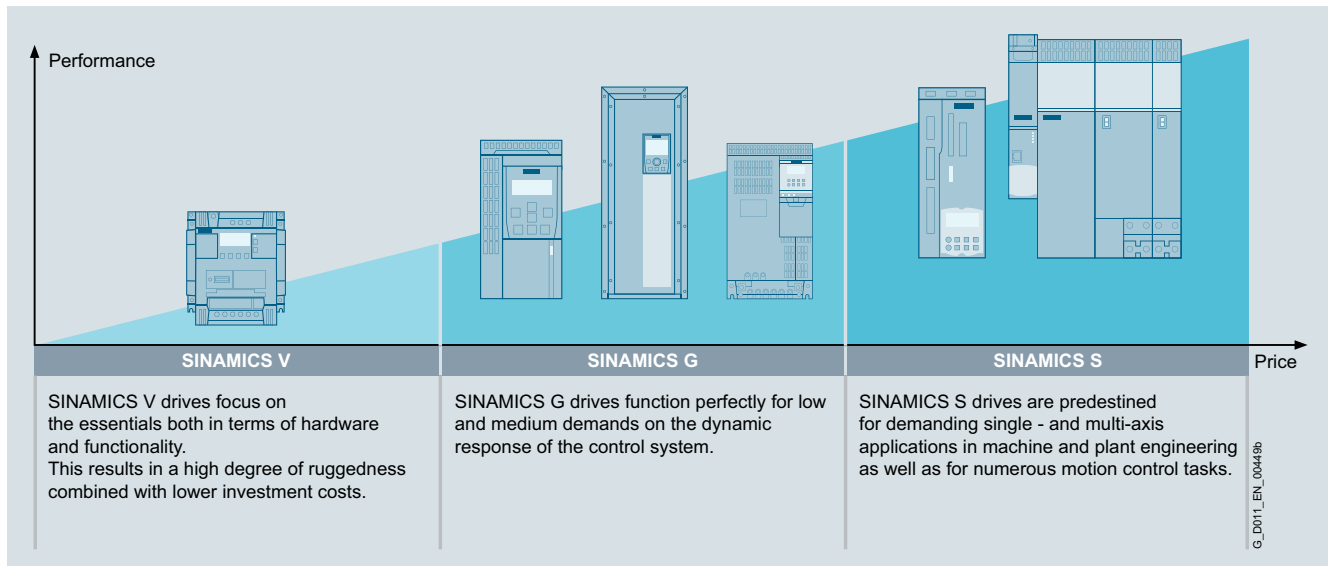

Overview

Platform concept

All SINAMICS variants are based on a platform concept. Joint hardware and software components, as well as standardized tools for dimensioning, configuration, and commissioning tasks ensure high-level integration across all components. SINAMICS handles a wide variety of drive tasks with no system gaps. The different SINAMICS variants can be easily combined with each other.

Quality management according to EN ISO 9001

SINAMICS conforms to the most exacting quality requirements. Comprehensive quality assurance measures in all development and production processes ensure a consistently high level of quality.

Of course, our quality management system is certified by an independent authority in accordance with EN ISO 9001.

IDS – Integration at its very best

The Siemens Integrated Drive Systems (IDS) solution offers perfectly matched drive components with which you can meet your requirements. The drive components reveal their true strengths as an Integrated Drive System over the full range from engineering and commissioning through to operation: Integrated system configuration is performed using the Drive Technology Configurator: Just select a motor and a converter and design them with the SIZER for Siemens Drives engineering tool. The STARTER and SINAMICS Startdrive commissioning tools integrate the motor data and at the same time simplify efficient commissioning. Integrated Drive Systems are incorporated in the TIA Portal – this simplifies engineering, commissioning and diagnostics.

Low voltage										Direct voltage	Medium voltage
Standard performance frequency converters		Distributed frequency converters	Industry-specific frequency converters		Servo drives			High performance frequency converters		DC converters	Converters for applications with high outputs
SINAMICS V20 G120C G120	SINAMICS G130 G150	SINAMICS G110D G120D G110M SIMATIC ET 200pro FC-2	SINAMICS G120X	SINAMICS G180	SINAMICS V90	SINAMICS S110	SINAMICS S210	SINAMICS S120 S120M	SINAMICS S150	SINAMICS DCM DCP *	SINAMICS GH150 GH180 GM150 SM150 GL150 SL150 SM120CM
0.12 kW to 250 kW	75 kW to 2700 kW	0.37 kW to 7.5 kW	0.75 kW to 630 kW	2.2 kW to 6600 kW	0.05 kW to 7 kW	0.55 kW to 132 kW	0.05 kW to 7 kW	0.55 kW to 5700 kW	75 kW to 1200 kW	6 kW to 30 MW	0.15 MW to 85 MW
Pumps, fans, compressors, conveyor belts, mixers, mills, spinning machines, textile machines, refrigerated display counters, fitness equipment, ventilation systems, single-axis positioning applications in machine and plant engineering	Pumps, fans, compressors, conveyor belts, mixers, mills, extruders	Conveyor technology, single-axis positioning applications (G120D)	Pumps, fans, compressors, building management systems, process industry, HVAC, water/waste water industries	Pumps, fans, compressors, conveyor belts, extruders, mixers, mills, kneaders, centrifuges, separators	Handling machines, packaging machines, automatic assembly machines, metal forming machines, printing machines, winding and unwinding units	Single-axis positioning applications in machine and plant engineering	Packaging machines, handling equipment, feed and withdrawal devices, stacking units, automatic assembly machines, laboratory automation, wood, glass and ceramics industry, digital printing machines	Production machines (packaging, textile and printing machines, paper machines, plastic processing machines), machine tools, plants, process lines and rolling mills, marine drives, test bays	Test bays, cross cutters, centrifuges	Rolling mill drives, wire-drawing machines, extruders and kneaders, cableways and lifts, test bay drives  * DC/DC controllers	Pumps, fans, compressors, mixers, extruders, mills, crushers, rolling mills, conveyor technology, excavators, test bays, marine drives, blast furnace fans, retrofit
Catalog D 31.1	Catalog D 11	Catalog D 31.2	Catalog D 31.5	Catalog D 18.1	Catalog D 33	Catalog D 31.1	Catalog D 32	Catalogs D 21.3, D 21.4, NC 62	Catalog D 21.3	Catalog D 23.1 * Industry Mall	Catalogs D 15.1, D 12

Engineering tools (e.g. Drive Technology Configurator, SIZER for Siemens Drives, STARTER and SINAMICS Startdrive)

G\_D011\_EN\_004500

# System overview

## Drive selection

1

### Overview

#### SINAMICS selection guide – typical applications

Use	Requirements for torque accuracy/speed accuracy/position accuracy/coordination of axes/functionality					
	Continuous motion			Non-continuous motion		
	Basic	Medium	High	Basic	Medium	High
<b>Pumping, ventilating, compressing</b> 	Centrifugal pumps Radial / axial fans Compressors V20 G120C G120X	Centrifugal pumps Radial / axial fans Compressors G120X G130/G150 G180 <sup>1)</sup>	Eccentric screw pumps S120	Hydraulic pumps Metering pumps G120	Hydraulic pumps Metering pumps S110	Descaling pumps Hydraulic pumps S120
<b>Moving</b> 	Conveyor belts Roller conveyors Chain conveyors V20 G110D G110M G120C ET 200pro FC-2 <sup>2)</sup>	Conveyor belts Roller conveyors Chain conveyors Lifting/lowering devices Elevators Escalators/moving walkways Indoor cranes Marine drives Cable railways G120 G120D G130/G150 G180 <sup>1)</sup>	Elevators Container cranes Mining hoists Excavators for open-cast mining Test bays S120 S150 DCM	Acceleration conveyors Storage and retrieval machines V90 G120 G120D	Acceleration conveyors Storage and retrieval machines Cross cutters Reel changers S110 <b>S210</b> DCM	Storage and retrieval machines Robotics Pick & place Rotary indexing tables Cross cutters Roll feeds Engagers/disengagers S120 <b>S210</b> DCM
<b>Processing</b> 	Mills Mixers Kneaders Crushers Agitators Centrifuges V20 G120C	Mills Mixers Kneaders Crushers Agitators Centrifuges Extruders Rotary furnaces G120 G130/G150 G180 <sup>1)</sup>	Extruders Winders/unwinders Lead/follower drives Calenders Main press drives Printing machines S120 S150 DCM	Tubular bagging machines Single-axis motion control such as • Position profiles • Path profiles V90 G120	Tubular bagging machines Single-axis motion control such as • Position profiles • Path profiles S110 <b>S210</b>	Servo presses Rolling mill drives Multi-axis motion control such as • Multi-axis positioning • Cams • Interpolations S120 <b>S210</b> DCM
<b>Machining</b> 	Main drives for • Turning • Milling • Drilling S110	Main drives for • Drilling • Sawing S110 S120	Main drives for • Turning • Milling • Drilling • Gear cutting • Grinding S120	Axis drives for • Turning • Milling • Drilling S110	Axis drives for • Drilling • Sawing S110 S120	Axis drives for • Turning • Milling • Drilling • Lasering • Gear cutting • Grinding • Nibbling and punching S120

#### Using the SINAMICS selection guide

The varying range of demands on modern variable frequency drives requires a large number of different types. Selecting the optimum drive has become a significantly more complex process. The application matrix shown simplifies this selection process considerably, by suggesting the ideal SINAMICS drive for examples of typical applications and requirements.

- The application type is selected from the vertical column
  - Pumping, ventilating, compressing
  - Moving
  - Processing
  - Machining
- The quality of the motion type is selected from the horizontal row
  - Basic
  - Medium
  - High

#### More Information

Further information about SINAMICS is available on the Internet at [www.siemens.com/sinamics](http://www.siemens.com/sinamics)

Practical application examples and descriptions are available on the Internet at [www.siemens.com/sinamics-applications](http://www.siemens.com/sinamics-applications)

<sup>1)</sup> Industry-specific converters.

<sup>2)</sup> Information on the SIMATIC ET 200pro FC-2 frequency converter is available in Catalog D 31.2 and at: [www.siemens.com/et200pro-fc](http://www.siemens.com/et200pro-fc)

## Overview



Example: SINAMICS S210 converter frame size FSB, 200 V 1 AC, with SIMOTICS S-1FK2 servomotor shaft height 30



Example: SINAMICS S210 converter frame size FSB, 400 V 3 AC, with SIMOTICS S-1FK2 servomotor shaft height 63

The new servo drive system comprises a SINAMICS S210 servo converter, a SIMOTICS S-1FK2 servomotor and a matching One Cable Connection (OCC) for connecting the motor to the converter. The SINAMICS S210 is a single-axis AC/AC servo converter system with high performance and dynamic response for mid-range Motion Control applications.

SINAMICS S210 servo converters are available for the following line voltages:

- 200 V to 240 V 1 AC (1 AC series)
- 200 V to 480 V 3 AC (3 AC series)

Depending on the converter voltage, the SIMOTICS S-1FK2 servomotors are available in the following frame sizes and torque ranges:

- **1 AC series**
  - Up to 240 V: Shaft heights 20 to 48 with 0.16 to 3.6 Nm
- **3 AC series**
  - Up to 240 V: Shaft heights 20 to 100 with 0.16 to 40 Nm
  - Up to 480 V: Shaft heights 40 to 100 with 1.27 to 40 Nm

The motors are available in the High Dynamic (HD) and Compact (CT) designs.

The SINAMICS S210 can be used in numerous applications. Typical applications are:

- Packaging machines
- Handling equipment
- Feed and withdrawal devices
- Stacking units
- Automatic assembly machines
- Laboratory automation
- Woodworking, glass and ceramic industries
- Digital printing machines

#### Flexible in application

The SINAMICS S210 is a flexible, versatile system. SIMOTICS S-1FK2 series synchronous servomotors are installed in rotary and linear axes. The integrated One Cable Connection (OCC) interface allows user-friendly connection of a SIMOTICS S-1FK2 motor with just one cable. The electronic motor type plate data can be read out, which eliminates the need to parameterize the converter with the motor data. This significantly simplifies and shortens commissioning.

In conjunction with the technological functions of the higher-level controller, there are many possibilities of motion – from continuous operation through positioning and synchronous operation, to coordinated motion of multiple axes via cyclic cams or interpolation – everything is possible.

The SINAMICS S210 converter has an integrated PROFINET communications interface for connecting to a control system.

The data exchange with the higher-level controllers takes place via standardized protocols – the PROFIdrive profile for positioning mode and the PROFIsafe profile for safety-related communication.

Thus, operation is optimally ensured with the SIMATIC S7 automation system. The drive axis is connected via technology objects and Motion Control blocks in the SIMATIC S7 or a SIMOTION controller.

#### High performance for fast and precise control

The high performance of the SINAMICS S210 servo drive system in conjunction with the SIMOTICS S-1FK2 servomotor derives from the following features:

- Low moment of inertia and high overload capability of the motor
- High-resolution encoder with fast scanning
- Current controller clock cycle of 62.5  $\mu$ s and a pulse frequency of 8 kHz of the servo converter

This enables short cycle times on the machine even with complex motion control.

#### DC link coupling (only 3 AC series)

For devices of the 3 AC series, the DC links of up to six converters can be coupled. Thus, energy balancing between the axes is possible and energy produced during braking can be used by other axes for accelerating. This is not only efficient but also reduces the dissipated heat in the control cabinet, because the energy that is produced no longer has to be converted to heat in the braking resistor.

# System overview

## SINAMICS S210 servo drive system

1

### Overview

#### Optimized connection technology with One Cable Connection (OCC)



Example: SINAMICS S210 M12 OCC connecting cable

Motor and converter are simply connected to one another by one instead of the usual two or three cables. With this One Cable Technology, energy supply, encoder signals and braking signal are brought together in a single cable. This results in the following advantages:

- Time-saving by laying only one cable
- Smaller installation space and space requirement in cable collars, tight bending radii
- Only one cable has to be cleaned. This is advantageous, e.g. in the pharmaceutical industry and where higher requirements are placed upon hygiene
- Can be ordered to the decimeter
- Compact connection system
- Rotatable connector on the motor side
- Motor with very low interfering contour for restricted installation space.

Cables are available in two different qualities:

- MOTION-CONNECT 500
- MOTION-CONNECT 800PLUS

In addition to the pre-assembled cable, individual components (connectors and products sold by the meter) can be ordered for self-assembly (available soon).

#### Easy commissioning via web server, One Button Tuning and SINAMICS Startdrive/TIA Portal (V15.1 or higher)

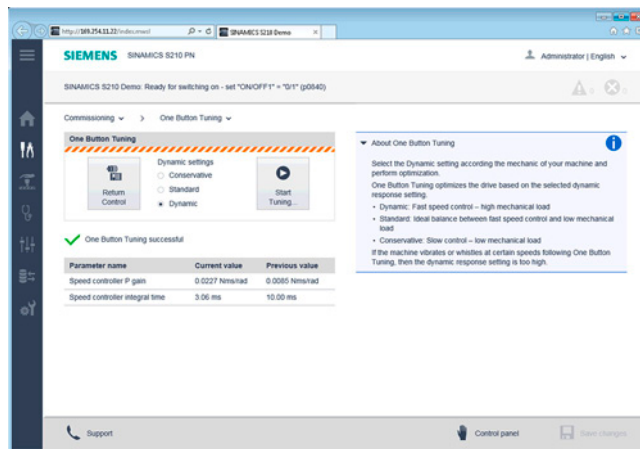

#### One Button Tuning

The web server of the converter offers a simple means of parameter assignment. The web server allows commissioning purely oriented on the functionality of the drive. With the web server, the SINAMICS S210 servo drive system can be brought into operation with a few clicks.

As a result of reading the electronic type plate of the connected SIMOTICS S-1FK2 servomotor, only a few operator actions, such as automatic controller optimization with One Button Tuning, are necessary, as the motor and encoder are automatically detected. The controller parameters are automatically optimized. The three selectable dynamic levels of the controller can optimally take into account the desired behavior of the connected mechanics.

A motion of the axis can take place directly via the control panel during commissioning.

The customer benefits from the web server in many ways:

- Commissioning can also be easily done in places difficult to access, as the web server in the converter can also be accessed directly via PROFINET from the controller.
- The web server provides full diagnostic capability without the need for additional software.
- Commissioning and diagnostics can also be done without a cable via mobile devices, such as laptops, smart phones and tablets (an additional WLAN access point is necessary).
- Intuitive user interface

In addition to easy commissioning directly via the web server of the converter, engineering is also possible with SINAMICS Startdrive and TIA Portal (V15.1 or higher). The tool for configuration, commissioning and diagnostics has been optimized with regard to the consistent utilization of the TIA Portal advantages – one shared work environment for PLC, HMI and drives. SINAMICS firmware V5.2 or higher is required for SINAMICS S210 devices.

For more information, see the [Engineering tools section](#).



## Overview

### Diagnostics

Faults and warnings are shown on the display located under the front cover, and they can be acknowledged with the Acknowledge button. Extensive diagnostics with plain text messages for cause and remedy information is possible via the web server.

### Safety Integrated

The integrated safety functions provide highly effective, application-oriented protection for personnel and machinery (terms as defined in IEC 61800-5-2).

The following Safety Integrated Basic Functions are included as standard:

- Safe Torque Off (STO)
- Safe Brake Control (SBC)
- Safe Stop 1 (SS1)

The following Safety Integrated Extended Functions <sup>1)</sup> are available as options:

- Safe Stop 2 (SS2)
- Safe Operating Stop (SOS)
- Safely-Limited Speed (SLS)
- Safe Speed Monitor (SSM)
- Safe Direction (SDI)
- Safely-Limited Acceleration (SLA)
- Safe Brake Test (SBT) diagnostic function

The Safety Integrated Functions are fully integrated into the drive system. They can be activated via fail-safe digital inputs on the converter (only STO and SS1) or via PROFINET with PROFIsafe.

The Safety Integrated Functions are implemented electronically and therefore require no additional installation effort or space in the control cabinet. Furthermore, the costs are considerably lower than for externally implemented monitoring functions.

The Safety Integrated Functions can be easily commissioned using the web server of the converter or SINAMICS Startdrive/TIA Portal V15.1 or higher.

### Perfect combination with SIMATIC S7-1500, SIMATIC S7-1500 T-CPU, SIMATIC ET 200SP Open Controller, and PROFINET

It communicates with the higher-level control via PROFINET IRT. For optimal interaction between the controller and the SINAMICS S210 servo drive system, SIMATIC S7-1500, SIMATIC S7-1500 T-CPU, SIMATIC ET 200SP Open Controller, and SIMOTION can be used as the control system.

The SINAMICS S210 servo converter has an integrated PROFINET communications interface with a cycle of up to 250 µs for connecting to a control system.

Standardized protocols for linking to a higher-level control with RT and IRT are supported – the PROFIdrive profile with DSC for positioning mode and the PROFIsafe profile for safety-related communication. Functions, such as Shared Device, ring redundancy and PROFInergy, are also possible.

Everything from one source: Through the use of Motion Control functionalities in the controller, the combination of converter and SIMATIC S7 automation system or a SIMOTION controller allows ideally harmonized engineering. As a result, commissioning times are shortened.

Via technology objects and Motion Control blocks of the higher-level controller, there are many possibilities of motion, such as continuous operation, positioning and synchronous operation, and coordinated motion of multiple axes via cyclic cams or interpolation.

Siemens offers tested SIMATIC PLC/HMI application examples for connection of the servo drive system to a SIMATIC controller: [www.siemens.com/sinamics-applications](http://www.siemens.com/sinamics-applications)

Further information on the SIMATIC S7-1500, SIMATIC S7-1500 T-CPU and SIMATIC ET 200SP Open Controller is available in the ST 70 Catalog and on the Internet under [www.siemens.com/simatic-s7-1500](http://www.siemens.com/simatic-s7-1500)

<sup>1)</sup> Available in SINAMICS V5.1 SP1 and higher. The Extended Functions require a Safety license.

## System overview

### SINAMICS S210 servo drive system

#### Overview

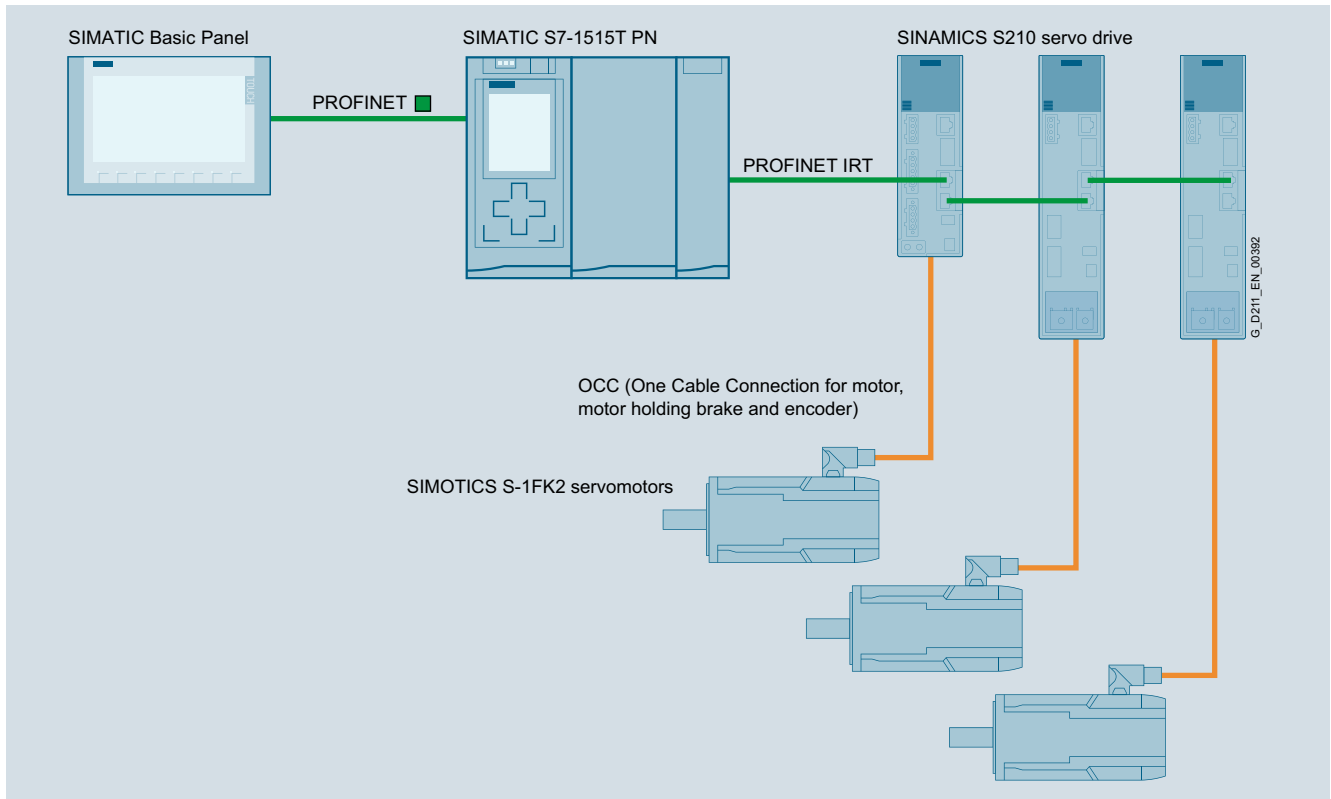

Example: Communication via PROFINET

#### Ruggedness

The SINAMICS S210 is equipped as standard with varnished or partially varnished modules. The painting on the modules protects the sensitive SMD components against corrosive gases, chemically active dust and moisture.

#### Can be used worldwide

In addition to the usual approvals, the SINAMICS S210 drive system also has UL approval for the North American market. This means that the drive system, comprising SINAMICS S210 and SIMOTICS S-1FK2, including the One Cable Connection (OCC), can be used worldwide.

#### More information

A **Quick Installation Guide** is supplied in hard copy form in English with every SINAMICS S210. Further documentation, such as the operating instructions, is available free on the Internet at:

[www.siemens.com/sinamics-s210/documentation](http://www.siemens.com/sinamics-s210/documentation)

Detailed information on the SINAMICS S210 drive system, including the latest technical documentation (brochures, tutorials, dimensional drawings, certificates, manuals and operating instructions), is available on the Internet at:

[www.siemens.com/sinamics-s210](http://www.siemens.com/sinamics-s210)

and is also available via the Drive Technology Configurator (DT Configurator) on the Internet.

The DT Configurator can be found in the Siemens Industry Mall at the following address:

[www.siemens.com/dt-configurator](http://www.siemens.com/dt-configurator)

Overview

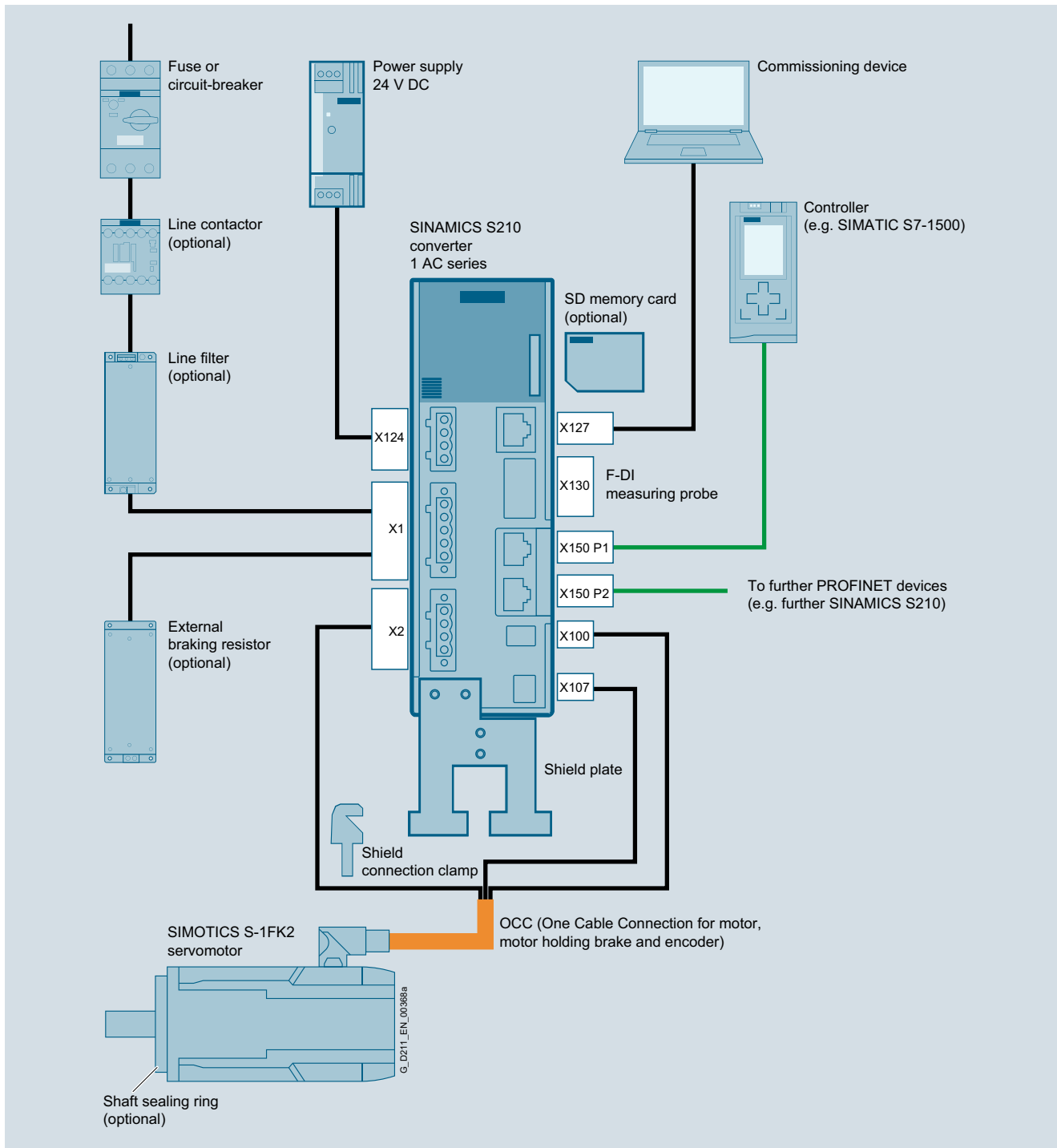

Example for the 1 AC series

# System overview

1

## SINAMICS S210 servo drive system

### Overview

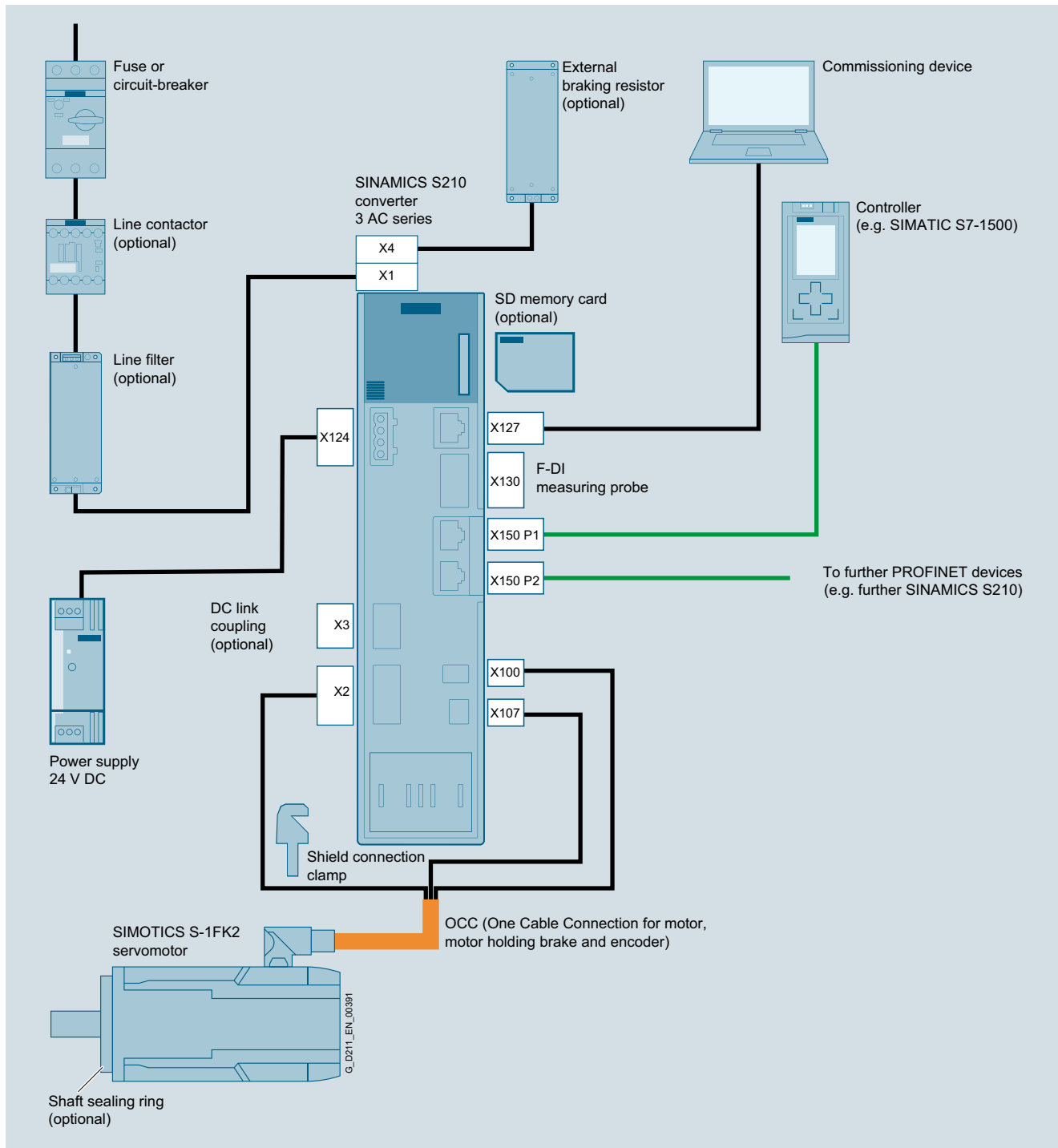

Example for the 3 AC series

6SL3255-0AA00-5AA0



## Order overview

## SINAMICS S210 drive system for line connection 200 ... 240 V 1 AC

SIMOTICS S-1FK2 servomotor							SINAMICS S210 servo converter (1 AC series) Supply voltage 200 ... 240 V 1 AC			MOTION-CONNECT motor connection cable
Static torque $M_0$ Nm (lb <sub>f</sub> -ft)	Maximum torque $M_{max}$ Nm (lb <sub>f</sub> -ft)	Maximum speed $n_{max}$ rpm	Rated power 230 V $P_{rated}$ kW (hp)	Rated torque $M_{rated}$ Nm (lb <sub>f</sub> -ft)	Rotor moment of inertia $J_{Mot}$ kg cm <sup>2</sup> (lb <sub>f</sub> -in <sup>2</sup> )	Article No.	Rated power 230 V $P_{rated}$ kW	Frame size	Article No.	Article No.
<b>High Dynamic for highly dynamic applications</b>							<b>SINAMICS S210 servo converter</b>			<b>One Cable Connection</b>
<b>Shaft height 20 – rated speed <math>n_{rated}</math> 3000 rpm</b>										
0.16 (0.12)	0.56 (0.41)	8000	0.05 (0.07)	0.16 (0.12)	0.025 (0.009)	<b>1FK2102-0AG</b> ■ ■ ■ ■ ■ A0	0.1	FSA	<b>6SL3210-5HB10-1UF0</b>	<b>6FX</b> ■ ■ ■ ■ ■ 002-8QN04-1 ■ ■ ■ ■ ■
0.32 (0.24)	1.11 (0.82)	8000	0.1 (0.13)	0.32 (0.24)	0.036 (0.012)	<b>1FK2102-1AG</b> ■ ■ ■ ■ ■ A0	0.1	FSA	<b>6SL3210-5HB10-1UF0</b>	<b>6FX</b> ■ ■ ■ ■ ■ 002-8QN04-1 ■ ■ ■ ■ ■
<b>Shaft height 30 – rated speed <math>n_{rated}</math> 3000 rpm</b>										
0.64 (0.47)	1.95 (1.44)	8000	0.2 (0.27)	0.64 (0.47)	0.093 (0.032)	<b>1FK2103-2AG</b> ■ ■ ■ ■ ■ A0	0.2	FSA	<b>6SL3210-5HB10-2UF0</b>	<b>6FX</b> ■ ■ ■ ■ ■ 002-8QN04-1 ■ ■ ■ ■ ■
1.27 (0.94)	4.05 (2.99)	7300	0.4 (0.54)	1.27 (0.94)	0.14 (0.048)	<b>1FK2103-4AG</b> ■ ■ ■ ■ ■ A0	0.4	FSB	<b>6SL3210-5HB10-4UF0</b>	<b>6FX</b> ■ ■ ■ ■ ■ 002-8QN04-1 ■ ■ ■ ■ ■
<b>Shaft height 40 – rated speed <math>n_{rated}</math> 1500 rpm</b>										
1.27 (0.94)	3.75 (2.77)	3600	0.2 (0.27)	1.27 (0.94)	0.35 (0.120)	<b>1FK2104-4AF</b> ■ ■ ■ ■ ■ A0	0.2	FSA	<b>6SL3210-5HB10-2UF0</b>	<b>6FX</b> ■ ■ ■ ■ ■ 002-8QN08-1 ■ ■ ■ ■ ■
2.4 (1.77)	7.5 (5.53)	3300	0.38 (0.51)	2.4 (1.77)	0.56 (0.191)	<b>1FK2104-5AF</b> ■ ■ ■ ■ ■ A0	0.4	FSB	<b>6SL3210-5HB10-4UF0</b>	<b>6FX</b> ■ ■ ■ ■ ■ 002-8QN08-1 ■ ■ ■ ■ ■
3.2 (2.36)	10 (7.38)	3600	0.5 (0.67)	3.2 (2.36)	0.76 (0.260)	<b>1FK2104-6AF</b> ■ ■ ■ ■ ■ A0	0.75	FSC	<b>6SL3210-5HB10-8UF0</b>	<b>6FX</b> ■ ■ ■ ■ ■ 002-8QN08-1 ■ ■ ■ ■ ■
<b>Shaft height 40 – rated speed <math>n_{rated}</math> 3000 rpm</b>										
1.27 (0.94)	3.85 (2.84)	7500	0.4 (0.54)	1.27 (0.94)	0.35 (0.120)	<b>1FK2104-4AK</b> ■ ■ ■ ■ ■ A0	0.4	FSB	<b>6SL3210-5HB10-4UF0</b>	<b>6FX</b> ■ ■ ■ ■ ■ 002-8QN08-1 ■ ■ ■ ■ ■
2.4 (1.77)	7.6 (5.61)	7100	0.75 (1.01)	2.4 (1.77)	0.56 (0.191)	<b>1FK2104-5AK</b> ■ ■ ■ ■ ■ A0	0.75	FSC	<b>6SL3210-5HB10-8UF0</b>	<b>6FX</b> ■ ■ ■ ■ ■ 002-8QN08-1 ■ ■ ■ ■ ■
<b>Compact for high precision applications</b>							<b>SINAMICS S210 servo converter</b>			<b>One Cable Connection</b>
<b>Shaft height 30 – rated speed <math>n_{rated}</math> 3000 rpm</b>										
0.64 (0.47)	1.85 (1.36)	8000	0.2 (0.27)	0.64 (0.47)	0.20 (0.068)	<b>1FK2203-2AG</b> ■ ■ ■ ■ ■ A0	0.2	FSA	<b>6SL3210-5HB10-2UF0</b>	<b>6FX</b> ■ ■ ■ ■ ■ 002-8QN04-1 ■ ■ ■ ■ ■
1.27 (0.94)	3.75 (2.77)	7800	0.4 (0.54)	1.27 (0.94)	0.35 (0.120)	<b>1FK2203-4AG</b> ■ ■ ■ ■ ■ A0	0.4	FSB	<b>6SL3210-5HB10-4UF0</b>	<b>6FX</b> ■ ■ ■ ■ ■ 002-8QN04-1 ■ ■ ■ ■ ■
<b>Shaft height 40 – rated speed <math>n_{rated}</math> 1500 rpm</b>										
2.4 (1.77)	7.1 (5.24)	3700	0.38 (0.51)	2.4 (1.77)	1.2 (0.410)	<b>1FK2204-5AF</b> ■ ■ ■ ■ ■ A0	0.4	FSB	<b>6SL3210-5HB10-4UF0</b>	<b>6FX</b> ■ ■ ■ ■ ■ 002-8QN08-1 ■ ■ ■ ■ ■
3.2 (2.36)	9.5 (7.01)	3800	0.5 (0.67)	3.2 (2.36)	1.6 (0.547)	<b>1FK2204-6AF</b> ■ ■ ■ ■ ■ A0	0.75	FSC	<b>6SL3210-5HB10-8UF0</b>	<b>6FX</b> ■ ■ ■ ■ ■ 002-8QN08-1 ■ ■ ■ ■ ■
<b>Shaft height 40 – rated speed <math>n_{rated}</math> 3000 rpm</b>										
2.4 (1.77)	7.1 (5.24)	7500	0.75 (1.01)	2.4 (1.77)	1.2 (0.410)	<b>1FK2204-5AK</b> ■ ■ ■ ■ ■ A0	0.75	FSC	<b>6SL3210-5HB10-8UF0</b>	<b>6FX</b> ■ ■ ■ ■ ■ 002-8QN08-1 ■ ■ ■ ■ ■
<b>Shaft height 48 – rated speed <math>n_{rated}</math> 1500 rpm</b>										
3.6 (2.66)	10.8 (7.97)	3200	0.53 (0.71)	3.4 (2.51)	3.2 (1.093)	<b>1FK2205-2AF</b> ■ ■ ■ ■ ■ A0	0.75	FSC	<b>6SL3210-5HB10-8UF0</b>	<b>6FX</b> ■ ■ ■ ■ ■ 002-8QN08-1 ■ ■ ■ ■ ■
<b>Article No. supplements</b>										
<b>Holding brake</b>										
Without brake							0			
With brake							1			
<b>Degree of protection</b>										
IP64 (without shaft sealing ring)							0			
IP65 (with shaft sealing ring)							1			
<b>Shaft extension / feather key</b>										
Plain shaft							0			
Shaft with feather key							1			
Plain shaft, reduced shaft diameter							0 2			
<ul style="list-style-type: none"> <li>• Ø11 × 23 mm (0.43 × 0.91 in) (only for 1FK2.03 and IP64)</li> <li>• Ø14 × 30 mm (0.55 × 1.18 in) (only for 1FK2.04 and IP64)</li> </ul>										
<b>Encoder</b>										
AS22DQC (absolute encoder 22-bit singleturn)							S			
AM22DQC (absolute encoder 22-bit + 12-bit multiturn)							M			
							<b>Pre-assembled MOTION-CONNECT cable</b>			
							MOTION-CONNECT 500			5
							MOTION-CONNECT 800PLUS			8
							<b>Length code (max. 50 m (164 ft))</b>			
							0 m (0 ft)			A
							10 m (32.8 ft)			B
							...			...
							50 m (164 ft)			F
							0 m (0 ft)			A
							1 m (3.28 ft)			B
							2 m (6.56 ft)			C
							3 m (9.84 ft)			D
							4 m (13.1 ft)			E
							5 m (16.4 ft)			F
							6 m (19.7 ft)			G
							7 m (23.0 ft)			H
							8 m (26.2 ft)			J
							9 m (29.5 ft)			K
							0 m (0 ft)			0
							0.1 m (0.33 ft)			1
							...			...
							0.8 m (2.62 ft)			8

## System overview

Clicking to the Industry Mall

6SL3255-0AA00-5AA0



## SINAMICS S210 servo drive system

## Order overview

## SINAMICS S210 drive system for line connection 200 ... 240 V 3 AC

SIMOTICS S-1FK2 servomotor							SINAMICS S210 servo converter (3 AC series) Supply voltage 200 ... 240 V 3 AC			MOTION-CONNECT motor connection cable
Static torque $M_0$ Nm (lb <sub>f</sub> -ft)	Maximum torque $M_{max}$ Nm (lb <sub>f</sub> -ft)	Maximum speed $n_{max}$ rpm	Rated power 240 V $P_{rated}$ kW (hp)	Rated torque $M_{rated}$ Nm (lb <sub>f</sub> -ft)	Rotor moment of inertia $J_{Mot}$ kg cm <sup>2</sup> (lb <sub>f</sub> -in <sup>2</sup> )	Article No.	Rated power 240 V $P_{rated}$ kW	Frame size	Article No.	Article No.
<b>High Dynamic for highly dynamic applications</b>							<b>SINAMICS S210 servo converter</b>			<b>One Cable Connection</b>
<b>Shaft height 20 – rated speed <math>n_{rated}</math> 3000 rpm</b>										
0.16 (0.12)	0.56 (0.41)	8000	0.05 (0.07)	0.16 (0.12)	0.025 (0.009)	<b>1FK2102-0AG</b>	0.24	FSA	<b>6SL3210-5HE10-4UF0</b>	<b>6FX002-8QN04-1</b>
0.32 (0.24)	1.11 (0.82)	8000	0.1 (0.13)	0.32 (0.24)	0.036 (0.012)	<b>1FK2102-1AG</b>	0.24	FSA	<b>6SL3210-5HE10-4UF0</b>	<b>6FX002-8QN04-1</b>
<b>Shaft height 30 – rated speed <math>n_{rated}</math> 3000 rpm</b>										
0.64 (0.47)	1.95 (1.44)	8000	0.2 (0.27)	0.64 (0.47)	0.093 (0.032)	<b>1FK2103-2AG</b>	0.45	FSA	<b>6SL3210-5HE10-8UF0</b>	<b>6FX002-8QN04-1</b>
1.27 (0.94)	4.05 (2.99)	8000	0.4 (0.54)	1.27 (0.94)	0.14 (0.048)	<b>1FK2103-4AG</b>	0.6	FSA	<b>6SL3210-5HE11-0UF0</b>	<b>6FX002-8QN04-1</b>
<b>Shaft height 40 – rated speed <math>n_{rated}</math> 1500 rpm</b>										
1.27 (0.94)	3.75 (2.77)	7200	0.2 (0.27)	1.27 (0.94)	0.35 (0.120)	<b>1FK2104-4AF</b>	0.24	FSA	<b>6SL3210-5HE10-4UF0</b>	<b>6FX002-8QN08-1</b>
2.4 (1.77)	7.5 (5.53)	6700	0.38 (0.51)	2.4 (1.77)	0.56 (0.191)	<b>1FK2104-5AF</b>	0.45	FSA	<b>6SL3210-5HE10-8UF0</b>	<b>6FX002-8QN08-1</b>
3.2 (2.36)	10 (7.38)	7200	0.5 (0.67)	3.2 (2.36)	0.76 (0.260)	<b>1FK2104-6AF</b>	0.6	FSA	<b>6SL3210-5HE11-0UF0</b>	<b>6FX002-8QN08-1</b>
<b>Shaft height 40 – rated speed <math>n_{rated}</math> 3000 rpm</b>										
1.27 (0.94)	3.85 (2.84)	8000	0.4 (0.54)	1.27 (0.94)	0.35 (0.120)	<b>1FK2104-4AK</b>	0.6	FSA	<b>6SL3210-5HE11-0UF0</b>	<b>6FX002-8QN08-1</b>
2.4 (1.77)	7.6 (5.61)	8000	0.75 (1.01)	2.4 (1.77)	0.56 (0.191)	<b>1FK2104-5AK</b>	0.9	FSB	<b>6SL3210-5HE11-5UF0</b>	<b>6FX002-8QN08-1</b>
<b>Shaft height 52 – rated speed <math>n_{rated}</math> 1500 rpm</b>										
5 (3.69)	15 (11.06)	6000	0.79 (1.06)	5 (3.69)	1.7 (0.581)	<b>1FK2105-4AF</b>	0.9	FSB	<b>6SL3210-5HE11-5UF0</b>	<b>6FX002-8QN08-1</b>
8 (5.90)	24 (17.70)	6000	1.26 (1.69)	8 (5.90)	2.7 (0.923)	<b>1FK2105-6AF</b>	1.2	FSB	<b>6SL3210-5HE12-0UF0</b>	<b>6FX002-8QN08-1</b>
<b>Shaft height 63 – rated speed <math>n_{rated}</math> 1500 rpm</b>										
9 (6.64)	24.5 (18.07)	6000	1.3 (1.74)	8.3 (6.12)	4.6 (1.572)	<b>1FK2106-3AF</b>	3	FSC	<b>6SL3210-5HE15-0UF0</b>	<b>6FX002-8QN11-1</b>
12 (8.85)	32.5 (23.97)	6000	1.64 (2.20)	10.5 (7.74)	6.0 (2.050)	<b>1FK2106-4AF</b>	3	FSC	<b>6SL3210-5HE15-0UF0</b>	<b>6FX002-8QN11-1</b>
16 (11.80)	42 (30.98)	6000	2.15 (2.88)	13.8 (10.18)	8.7 (2.973)	<b>1FK2106-6AF</b>	4.2	FSC	<b>6SL3210-5HE17-0UF0</b>	<b>6FX002-8QN11-1</b>

## Article No. supplements

## Holding brake

Without brake	0
With brake	1

## Degree of protection

IP64 (without shaft sealing ring)	0
IP65 (with shaft sealing ring)	1

## Shaft extension / feather key

Plain shaft	0
Shaft with feather key	1
Plain shaft, reduced shaft diameter	0 2
• $\varnothing 11 \times 23$ mm (0.43 × 0.91 in) (only for 1FK2.03 and IP64)	
• $\varnothing 14 \times 30$ mm (0.55 × 1.18 in) (only for 1FK2.04 and IP64)	

## Encoder

AS22DQC (absolute encoder 22-bit singleturn)	S
AM22DQC (absolute encoder 22-bit + 12-bit multiturn)	M

## Pre-assembled MOTION-CONNECT cable

MOTION-CONNECT 500	5
MOTION-CONNECT 800PLUS	8

## Length code (max. 50 m (164 ft))

0 m (0 ft)	A
10 m (32.8 ft)	B
...	...
50 m (164 ft)	F
0 m (0 ft)	A
1 m (3.28 ft)	B
2 m (6.56 ft)	C
3 m (9.84 ft)	D
4 m (13.1 ft)	E
5 m (16.4 ft)	F
6 m (19.7 ft)	G
7 m (23.0 ft)	H
8 m (26.2 ft)	J
9 m (29.5 ft)	K

0 m (0 ft)	0
0.1 m (0.33 ft)	1
...	...
0.8 m (2.62 ft)	8

When operating a SINAMICS S210 servo converter with a supply voltage of 200 V to 240 V 3 AC, an external, intrinsically safe braking resistor is always required.

6SL3255-0AA00-5AA0



## Order overview

## SINAMICS S210 drive system for line connection 200 ... 240 V 3 AC (continued)

SIMOTICS S-1FK2 servomotor							SINAMICS S210 servo converter (3 AC series) Supply voltage 200 ... 240 V 3 AC			MOTION-CONNECT motor connection cable
Static torque $M_0$ Nm (lb <sub>f</sub> -ft)	Maximum torque $M_{max}$ Nm (lb <sub>f</sub> -ft)	Maximum speed $n_{max}$ rpm	Rated power 240 V $P_{rated}$ kW (hp)	Rated torque $M_{rated}$ Nm (lb <sub>f</sub> -ft)	Rotor moment of inertia $J_{Mot}$ kg cm <sup>2</sup> (lb <sub>f</sub> -in <sup>2</sup> )	Article No.	Rated power 240 V $P_{rated}$ kW	Frame size	Article No.	Article No.
<b>Compact for high precision applications</b>							<b>SINAMICS S210 servo converter</b>			<b>One Cable Connection</b>
<b>Shaft height 30 – rated speed <math>n_{rated}</math> 3000 rpm</b>										
0.64 (0.47)	1.85 (1.36)	8000	0.2 (0.27)	0.64 (0.47)	0.20 (0.068)	<b>1FK2203-2AG</b>	0.45	FSA	<b>6SL3210-5HE10-8UF0</b>	<b>6FX002-8QN04-1</b>
1.27 (0.94)	3.75 (2.77)	8000	0.4 (0.54)	1.27 (0.94)	0.35 (0.120)	<b>1FK2203-4AG</b>	0.6	FSA	<b>6SL3210-5HE11-0UF0</b>	<b>6FX002-8QN04-1</b>
<b>Shaft height 40 – rated speed <math>n_{rated}</math> 1500 rpm</b>										
2.4 (1.77)	7.1 (5.24)	7500	0.38 (0.51)	2.4 (1.77)	1.2 (0.410)	<b>1FK2204-5AF</b>	0.45	FSA	<b>6SL3210-5HE10-8UF0</b>	<b>6FX002-8QN08-1</b>
3.2 (2.36)	9.5 (7.01)	7600	0.5 (0.67)	3.2 (2.36)	1.6 (0.547)	<b>1FK2204-6AF</b>	0.6	FSA	<b>6SL3210-5HE11-0UF0</b>	<b>6FX002-8QN08-1</b>
<b>Shaft height 40 – rated speed <math>n_{rated}</math> 3000 rpm</b>										
2.4 (1.77)	7.1 (5.24)	8000	0.75 (1.01)	2.4 (1.77)	1.2 (0.410)	<b>1FK2204-5AK</b>	0.9	FSB	<b>6SL3210-5HE11-5UF0</b>	<b>6FX002-8QN08-1</b>
<b>Shaft height 48 – rated speed <math>n_{rated}</math> 1500 rpm</b>										
3.6 (2.66)	10.8 (7.97)	6000	0.53 (0.71)	3.4 (2.51)	3.2 (1.093)	<b>1FK2205-2AF</b>	0.6	FSA	<b>6SL3210-5HE11-0UF0</b>	<b>6FX002-8QN08-1</b>
6 (4.43)	18 (13.28)	6000	0.86 (1.15)	5.5 (4.06)	5.1 (1.743)	<b>1FK2205-4AF</b>	0.9	FSB	<b>6SL3210-5HE11-5UF0</b>	<b>6FX002-8QN08-1</b>
<b>Shaft height 63 – rated speed <math>n_{rated}</math> 1500 rpm</b>										
6.5 (4.79)	18 (13.28)	6000	0.97 (1.30)	6.1 (4.50)	7.8 (2.665)	<b>1FK2206-2AF</b>	0.9	FSB	<b>6SL3210-5HE11-5UF0</b>	<b>6FX002-8QN11-1</b>
12 (8.85)	36 (26.55)	5800	1.72 (2.31)	10.9 (8.04)	15 (5.126)	<b>1FK2206-4AF</b>	2.1	FSC	<b>6SL3210-5HE13-5UF0</b>	<b>6FX002-8QN11-1</b>
<b>Shaft height 80 – rated speed <math>n_{rated}</math> 1000 rpm</b>										
18 (13.28)	51 (37.62)	4100	1.74 (2.33)	16.6 (12.24)	30 (10.251)	<b>1FK2208-3AC</b>	2.1	FSC	<b>6SL3210-5HE13-5UF0</b>	<b>6FX002-8QN11-1</b>
22 (16.23)	66 (48.68)	4600	2.15 (2.88)	20 (14.75)	39 (13.326)	<b>1FK2208-4AC</b>	3	FSC	<b>6SL3210-5HE15-0UF0</b>	<b>6FX002-8QN11-1</b>
27 (19.92)	80 (59.01)	4700	2.5 (3.35)	23.5 (17.33)	48 (16.402)	<b>1FK2208-5AC</b>	4.2	FSC	<b>6SL3210-5HE17-0UF0</b>	<b>6FX002-8QN11-1</b>
<b>Shaft height 100 – rated speed <math>n_{rated}</math> 750 rpm</b>										
30 (22.13)	90 (66.38)	2500	2.5 (3.35)	30 (22.13)	89 (30.411)	<b>1FK2210-3AB</b>	2.1	FSC	<b>6SL3210-5HE13-5UF0</b>	<b>6FX002-8QN11-1</b>
40 (29.50)	120 (88.51)	2500	3.05 (4.09)	39 (28.77)	120 (41.004)	<b>1FK2210-4AB</b>	3	FSC	<b>6SL3210-5HE15-0UF0</b>	<b>6FX002-8QN11-1</b>
<b>Shaft height 100 – rated speed <math>n_{rated}</math> 1000 rpm</b>										
30 (22.13)	90 (66.38)	4400	3.2 (4.29)	30 (22.13)	89 (30.411)	<b>1FK2210-3AC</b>	4.2	FSC	<b>6SL3210-5HE17-0UF0</b>	<b>6FX002-8QN11-1</b>
40 (29.50)	120 (88.51)	3300	3.9 (5.23)	37 (27.29)	120 (41.004)	<b>1FK2210-4AC</b>	4.2	FSC	<b>6SL3210-5HE17-0UF0</b>	<b>6FX002-8QN11-1</b>

## Article No. supplements

<b>Holding brake</b>	
Without brake	0
With brake	1
<b>Degree of protection</b>	
IP64 (without shaft sealing ring)	0
IP65 (with shaft sealing ring)	1
<b>Shaft extension / feather key</b>	
Plain shaft	0
Shaft with feather key	1
Plain shaft, reduced shaft diameter	0 2
• Ø11 × 23 mm (0.43 × 0.91 in) (only for 1FK2.03 and IP64)	
• Ø14 × 30 mm (0.55 × 1.18 in) (only for 1FK2.04 and IP64)	
<b>Encoder</b>	
AS22DQC (absolute encoder 22-bit singleturn)	S
AM22DQC (absolute encoder 22-bit + 12-bit multiturn)	M

<b>Pre-assembled MOTION-CONNECT cable</b>	
MOTION-CONNECT 500	5
MOTION-CONNECT 800PLUS	8

<b>Length code (max. 50 m (164 ft))</b>	
0 m (0 ft)	A
10 m (32.8 ft)	B
...	...
50 m (164 ft)	F
0 m (0 ft)	A
1 m (3.28 ft)	B
2 m (6.56 ft)	C
3 m (9.84 ft)	D
4 m (13.1 ft)	E
5 m (16.4 ft)	F
6 m (19.7 ft)	G
7 m (23.0 ft)	H
8 m (26.2 ft)	J
9 m (29.5 ft)	K

0 m (0 ft)	0
0.1 m (0.33 ft)	1
...	...
0.8 m (2.62 ft)	8

When operating a SINAMICS S210 servo converter with a supply voltage of 200 V to 240 V 3 AC, an external, intrinsically safe braking resistor is always required.

# System overview

Clicking to the Industry Mall

6SL3255-0AA00-5AA0



1

## SINAMICS S210 servo drive system

### Order overview

#### SINAMICS S210 drive system for line connection 380 ... 480 V 3 AC

SIMOTICS S-1FK2 servomotor							SINAMICS S210 servo converter (3 AC series) Supply voltage 380 ... 480 V 3 AC			MOTION-CONNECT motor connection cable	
Static torque	Maximum torque	Maximum speed	Rated power 400 V	Rated torque	Rotor moment of inertia	Article No.	Rated power 400 V	Frame size	Article No.	Article No.	
$M_0$ Nm (lb <sub>f</sub> -ft)	$M_{max}$ Nm (lb <sub>f</sub> -ft)	$n_{max}$ rpm	$P_{rated}$ kW (hp)	$M_{rated}$ Nm (lb <sub>f</sub> -ft)	$J_{Mot}$ kg cm <sup>2</sup> (lb <sub>f</sub> -in <sup>2</sup> )		$P_{rated}$ kW				
<b>High Dynamic for highly dynamic applications</b>							SINAMICS S210 servo converter			<b>One Cable Connection</b>	
<b>Shaft height 40 – rated speed <math>n_{rated}</math> 3000 rpm</b>											
1.27 (0.94)	3.75 (2.77)	7200	0.4 (0.54)	1.27 (0.94)	0.35 (0.120)	<b>1FK2104-4AF-...-...A0</b>	0.4	FSA	<b>6SL3210-5HE10-4UF0</b>	<b>6FX...002-8QN08-1...</b>	
2.4 (1.77)	7.5 (5.53)	6700	0.75 (1.01)	2.4 (1.77)	0.56 (0.191)	<b>1FK2104-5AF-...-...A0</b>	0.75	FSA	<b>6SL3210-5HE10-8UF0</b>	<b>6FX...002-8QN08-1...</b>	
3.2 (2.36)	10 (7.38)	7200	1 (1.34)	3.2 (2.36)	0.76 (0.260)	<b>1FK2104-6AF-...-...A0</b>	1	FSA	<b>6SL3210-5HE11-0UF0</b>	<b>6FX...002-8QN08-1...</b>	
<b>Shaft height 52 – rated speed <math>n_{rated}</math> 3000 rpm</b>											
5 (3.69)	15 (11.06)	6000	1.45 (1.94)	4.6 (3.39)	1.7 (0.581)	<b>1FK2105-4AF-...-...A0</b>	1.5	FSB	<b>6SL3210-5HE11-5UF0</b>	<b>6FX...002-8QN08-1...</b>	
8 (5.90)	24 (17.70)	6000	2.1 (2.82)	6.6 (4.87)	2.7 (0.923)	<b>1FK2105-6AF-...-...A0</b>	2	FSB	<b>6SL3210-5HE12-0UF0</b>	<b>6FX...002-8QN08-1...</b>	
<b>Shaft height 63 – rated speed <math>n_{rated}</math> 3000 rpm</b>											
9 (6.64)	24.5 (18.07)	6000	2.3 (3.08)	7.3 (5.38)	4.6 (1.572)	<b>1FK2106-3AF-...-...A0</b>	5	FSC	<b>6SL3210-5HE15-0UF0</b>	<b>6FX...002-8QN11-1...</b>	
12 (8.85)	32.5 (23.97)	6000	2.7 (3.62)	8.6 (6.34)	6.0 (2.050)	<b>1FK2106-4AF-...-...A0</b>	5	FSC	<b>6SL3210-5HE15-0UF0</b>	<b>6FX...002-8QN11-1...</b>	
16 (11.80)	42 (30.98)	6000	3.3 (4.43)	10.6 (7.82)	8.7 (2.973)	<b>1FK2106-6AF-...-...A0</b>	7	FSC	<b>6SL3210-5HE17-0UF0</b>	<b>6FX...002-8QN11-1...</b>	
<b>Article No. supplements</b>											
<b>Holding brake</b>											
Without brake	<b>0</b>										
With brake	<b>1</b>										
<b>Degree of protection</b>											
IP64 (without shaft sealing ring)	<b>0</b>										
IP65 (with shaft sealing ring)	<b>1</b>										
<b>Shaft extension / feather key</b>											
Plain shaft	<b>0</b>										
Shaft with feather key	<b>1</b>										
Plain shaft, reduced shaft diameter	<b>0 2</b>										
• $\varnothing 11 \times 23$ mm (0.43 × 0.91 in) (only for 1FK2.03 and IP64)											
• $\varnothing 14 \times 30$ mm (0.55 × 1.18 in) (only for 1FK2.04 and IP64)											
<b>Encoder</b>											
AS22DQC (absolute encoder 22-bit singleturn)	<b>S</b>										
AM22DQC (absolute encoder 22-bit + 12-bit multiturn)	<b>M</b>										
<b>Pre-assembled MOTION-CONNECT cable</b>											
MOTION-CONNECT 500	<b>5</b>										
MOTION-CONNECT 800PLUS	<b>8</b>										
<b>Length code (max. 50 m (164 ft))</b>											
0 m (0 ft)	<b>A</b>										
10 m (32.8 ft)	<b>B</b>										
...	<b>...</b>										
50 m (164 ft)	<b>F</b>										
0 m (0 ft)	<b>A</b>										
1 m (3.28 ft)	<b>B</b>										
2 m (6.56 ft)	<b>C</b>										
3 m (9.84 ft)	<b>D</b>										
4 m (13.1 ft)	<b>E</b>										
5 m (16.4 ft)	<b>F</b>										
6 m (19.7 ft)	<b>G</b>										
7 m (23.0 ft)	<b>H</b>										
8 m (26.2 ft)	<b>J</b>										
9 m (29.5 ft)	<b>K</b>										
0 m (0 ft)	<b>0</b>										
0.1 m (0.33 ft)	<b>1</b>										
...	<b>...</b>										
0.8 m (2.62 ft)	<b>8</b>										



6SL3255-0AA00-5AA0



## Order overview

## SINAMICS S210 drive system for line connection 380 ... 480 V 3 AC (continued)

SIMOTICS S-1FK2 servomotor							SINAMICS S210 servo converter (3 AC series) Supply voltage 380 ... 480 V 3 AC			MOTION-CONNECT motor connection cable
Static torque $M_0$ Nm (lb <sub>f</sub> -ft)	Maximum torque $M_{max}$ Nm (lb <sub>f</sub> -ft)	Maximum speed $n_{max}$ rpm	Rated power 400 V $P_{rated}$ kW (hp)	Rated torque $M_{rated}$ Nm (lb <sub>f</sub> -ft)	Rotor moment of inertia $J_{Mot}$ kg cm <sup>2</sup> (lb <sub>f</sub> -in <sup>2</sup> )	Article No.	Rated power 400 V $P_{rated}$ kW	Frame size	Article No.	Article No.
<b>Compact for high precision applications</b>							<b>SINAMICS S210 servo converter</b>			<b>One Cable Connection</b>
<b>Shaft height 40 – rated speed <math>n_{rated}</math> 3000 rpm</b>										
2.4 (1.77)	7.1 (5.24)	7500	0.75 (1.01)	2.4 (1.77)	1.2 (0.410)	<b>1FK2204-5AF-...-...A0</b>	0.75	FSA	<b>6SL3210-5HE10-8UF0</b>	<b>6FX...002-8QN08-1...</b>
3.2 (2.36)	9.5 (7.01)	7600	1 (1.34)	3.2 (2.36)	1.6 (0.547)	<b>1FK2204-6AF-...-...A0</b>	1	FSA	<b>6SL3210-5HE11-0UF0</b>	<b>6FX...002-8QN08-1...</b>
<b>Shaft height 40 – rated speed <math>n_{rated}</math> 6000 rpm</b>										
2.4 (1.77)	7.1 (5.24)	8000	0.57 (0.76)	0.9 (0.66)	1.2 (0.410)	<b>1FK2204-5AK-...-...A0</b>	1.5	FSB	<b>6SL3210-5HE11-5UF0</b>	<b>6FX...002-8QN08-1...</b>
<b>Shaft height 48 – rated speed <math>n_{rated}</math> 3000 rpm</b>										
3.6 (2.66)	10.8 (7.97)	6000	0.94 (1.26)	3 (2.21)	3.2 (1.093)	<b>1FK2205-2AF-...-...A0</b>	1	FSA	<b>6SL3210-5HE11-0UF0</b>	<b>6FX...002-8QN08-1...</b>
6 (4.43)	18 (13.28)	6000	1.45 (1.94)	4.6 (3.39)	5.1 (1.743)	<b>1FK2205-4AF-...-...A0</b>	1.5	FSB	<b>6SL3210-5HE11-5UF0</b>	<b>6FX...002-8QN08-1...</b>
<b>Shaft height 63 – rated speed <math>n_{rated}</math> 3000 rpm</b>										
6.5 (4.79)	18 (13.28)	6000	1.71 (2.29)	5.4 (3.98)	7.8 (2.665)	<b>1FK2206-2AF-...-...A0</b>	1.5	FSB	<b>6SL3210-5HE11-5UF0</b>	<b>6FX...002-8QN11-1...</b>
12 (8.85)	36 (26.55)	5800	2.85 (3.82)	9.1 (6.71)	15 (5.126)	<b>1FK2206-4AF-...-...A0</b>	3.5	FSC	<b>6SL3210-5HE13-5UF0</b>	<b>6FX...002-8QN11-1...</b>
<b>Shaft height 80 – rated speed <math>n_{rated}</math> 2000 rpm</b>										
18 (13.28)	51 (37.62)	4100	3.05 (4.09)	14.5 (10.70)	30 (10.251)	<b>1FK2208-3AC-...-...A0</b>	3.5	FSC	<b>6SL3210-5HE13-5UF0</b>	<b>6FX...002-8QN11-1...</b>
22 (16.23)	66 (48.68)	4600	3.55 (4.76)	17 (12.54)	39 (13.326)	<b>1FK2208-4AC-...-...A0</b>	5	FSC	<b>6SL3210-5HE15-0UF0</b>	<b>6FX...002-8QN11-1...</b>
27 (19.92)	80 (59.01)	4700	4 (5.36)	19.1 (14.09)	48 (16.402)	<b>1FK2208-5AC-...-...A0</b>	7	FSC	<b>6SL3210-5HE17-0UF0</b>	<b>6FX...002-8QN11-1...</b>
<b>Shaft height 100 – rated speed <math>n_{rated}</math> 1500 rpm</b>										
30 (22.13)	90 (66.38)	2500	4.5 (6.03)	28.5 (21.02)	89 (30.411)	<b>1FK2210-3AB-...-...A0</b>	3.5	FSC	<b>6SL3210-5HE13-5UF0</b>	<b>6FX...002-8QN11-1...</b>
40 (29.50)	120 (88.51)	2500	5.4 (7.24)	34.5 (25.45)	120 (41.004)	<b>1FK2210-4AB-...-...A0</b>	5	FSC	<b>6SL3210-5HE15-0UF0</b>	<b>6FX...002-8QN11-1...</b>
<b>Shaft height 100 – rated speed <math>n_{rated}</math> 2000 rpm</b>										
30 (22.13)	90 (66.38)	4400	5.5 (7.38)	26 (19.18)	89 (30.411)	<b>1FK2210-3AC-...-...A0</b>	7	FSC	<b>6SL3210-5HE17-0UF0</b>	<b>6FX...002-8QN11-1...</b>
40 (29.50)	120 (88.51)	3300	6.4 (8.58)	30.5 (22.50)	120 (41.004)	<b>1FK2210-4AC-...-...A0</b>	7	FSC	<b>6SL3210-5HE17-0UF0</b>	<b>6FX...002-8QN11-1...</b>
<b>Article No. supplements</b>										
<b>Holding brake</b>							<b>Pre-assembled MOTION-CONNECT cable</b>			
Without brake							MOTION-CONNECT 500			
With brake							MOTION-CONNECT 800PLUS			
<b>Degree of protection</b>							<b>Length code (max. 50 m (164 ft))</b>			
IP64 (without shaft sealing ring)							0 m (0 ft)			
IP65 (with shaft sealing ring)							10 m (32.8 ft)			
							...			
							50 m (164 ft)			
<b>Shaft extension / feather key</b>										
Plain shaft							0 m (0 ft)			
Shaft with feather key							1 m (3.28 ft)			
Plain shaft, reduced shaft diameter							2 m (6.56 ft)			
• Ø11 × 23 mm (0.43 × 0.91 in) (only for 1FK2.03 and IP64)							3 m (9.84 ft)			
• Ø14 × 30 mm (0.55 × 1.18 in) (only for 1FK2.04 and IP64)							4 m (13.1 ft)			
							5 m (16.4 ft)			
							6 m (19.7 ft)			
							7 m (23.0 ft)			
							8 m (26.2 ft)			
							9 m (29.5 ft)			
<b>Encoder</b>										
AS22DQC (absolute encoder 22-bit singleturn)							0 m (0 ft)			
AM22DQC (absolute encoder 22-bit + 12-bit multiturn)							0.1 m (0.33 ft)			
							...			
							0.8 m (2.62 ft)			



## SINAMICS S210 servo drive system

1

## Order overview

## Accessories for SINAMICS S210 servo converters

Description	Article No.
<b>SINAMICS SD card (optional)</b> 512 MB The parameter assignment, firmware and licenses for a converter can be stored on this memory card. Firmware V5.2 or higher is required for the 3 AC series.	
<ul style="list-style-type: none"> <li>Empty</li> <li>With firmware V5.1</li> <li>With firmware V5.1 SP1</li> <li>With firmware V5.1 SP1 and Safety license (Extended Functions)</li> <li>With firmware V5.2</li> <li>With firmware V5.2 and Safety license (Extended Functions)</li> <li>With firmware V5.2 SP3</li> <li>With firmware V5.2 SP3 and Safety license (Extended Functions)</li> </ul>	6SL3054-4AG00-2AA0 6SL3054-4FB00-2BA0 6SL3054-4FB10-2BA0 6SL3054-4FB10-2BA0-Z F01 6SL3054-4FC00-2BA0 6SL3054-4FC00-2BA0-Z F01 <b>NEW</b> 6SL3054-4FC30-2BA0 <b>NEW</b> 6SL3054-4FC30-2BA0-Z F01
<b>Safety license</b> (Extended Functions) <sup>1)</sup> <ul style="list-style-type: none"> <li>CoL in paper form</li> <li>CoL in electronic form</li> </ul>	6SL3074-0AA10-0AA0 <b>NEW</b> 6SL3074-0AA10-0AH0
<b>PROFINET patch cable</b> For the networking of concatenated converters <ul style="list-style-type: none"> <li>0.3 m</li> <li>0.5 m</li> </ul>	6XV1870-3QE30 6XV1870-3QE50
<b>Only for the 1 AC series</b>	
<b>Line filter</b> <b>NEW</b> With this line filter, Category C2 for cable lengths up to 25 m (82 ft), Category C3 for cable lengths up to 50 m (164 ft) acc. to IEC 61800-3 can be achieved.	6SL3203-0BB21-8VA1
<b>Only for the 3 AC series</b>	
<b>Line filter</b> With these line filters, Category C2 for cable lengths up to 25 m (82 ft), Category C3 for cable lengths up to 50 m (164 ft) acc. to IEC 61800-3 can be achieved. When connected via a DC link, a total cable length of up to 100 m (328 ft) with Category C2 and up to 250 m (820 ft) with Category C3 is possible <sup>2)</sup> <ul style="list-style-type: none"> <li>≤ 35 A</li> <li>≤ 65 A</li> </ul>	<b>NEW</b> 6SL3203-0BE23-5HA0 <b>NEW</b> 6SL3203-0BE26-5HA0
<b>Connector set AC bus and DC link</b> For coupling the DC link and the line infeed Scope of delivery: 1 AC bus connector, 1 DC link connector, 2 cover caps The AC bus connector replaces the push-in connector included in the scope of delivery of the converter. Wiring is performed with conventional 16 mm <sup>2</sup> cable (not included in scope of delivery) <sup>3)</sup>	6SL3260-2DC00-0AA0
<b>Connector set AC bus individual</b> For coupling the line infeed Scope of delivery: 1 AC bus connector, 1 cover cap This connector replaces the push-in connector included in the scope of delivery of the converter. Wiring is performed with conventional 16 mm <sup>2</sup> cable (not included in scope of delivery) <sup>3)</sup>	6SL3260-2DC10-0AA0
<b>External braking resistors for 200 ... 240 V 3 AC</b> For a supply voltage of 200 V to 240 V 3 AC, an external, intrinsically safe braking resistor is always required for each converter <ul style="list-style-type: none"> <li>100 W, 47 Ω for FSA and FSB</li> <li>240 W, 14 Ω for FSC</li> </ul>	<b>NEW</b> GXK:BWG250047TS-190 <b>NEW</b> GXK:BWG600014TS-190

## Accessories for SIMOTICS S-1FK2 servomotors

Description	For motor	Article No.
<b>Shaft sealing ring (optional)</b>	1FK2.02	<b>1FK2902-0GC00</b>
To achieve degree of protection IP65 for retrofitting or as spare part	1FK2.03	<b>1FK2903-0GC00</b>
	1FK2.04	<b>1FK2904-0GC00</b>

## Starter kit

Description	Article No.
<b>SINAMICS S210 starter kit with Extended Safety</b> Scope of delivery: <ul style="list-style-type: none"> <li>SINAMICS S210 servo converter, 230 V 1 AC, 400 W</li> <li>SIMOTICS S-1FK2 servomotor, High Dynamic, shaft height 30, 400 W, without brake, shaft with feather key, with absolute encoder multiturn</li> <li>One Cable Connection (OCC) motor connection cables, 3 m (9.84 ft)</li> <li>Memory card with firmware V5.2 and Safety license (Extended Functions)</li> </ul> The delivery quantity is limited to three units per customer	<b>6SL3200-0AE61-0AA0</b>

## Training case

Description	Article No.
<b>SINAMICS S210 training case</b> Scope of delivery: <ul style="list-style-type: none"> <li>2 × SINAMICS S210 servo converters, 0.1 kW, 230 V 1 AC</li> <li>2 × SIMOTICS S-1FK2 servomotors, High Dynamic</li> <li>2 × One Cable Connection (OCC) motor connection cables</li> <li>Rail, prepared for installation of a controller, e.g. SIMATIC S7-1500 (controller not included in scope of delivery)</li> </ul> The SINAMICS S210 training case is supplied as a trolley with a hood.	<b>6AG1067-1AA33-0AA0</b>

- Extended function for an existing memory card (firmware V5.1 SP1 or higher). The memory card is not included in the scope of delivery. The Safety license can also be ordered together with a memory card (see above). With a CoL in electronic form, the license is supplied as a PDF file. Notification of this with a download link is received by email. For further information, see section [Supplementary system components > Memory cards](#).
- The data is applicable for the complete cable length of the motors, whose associated converters are coupled with one another via an AC coupling or through the DC link.  
The maximum cable length per motor is 25 m using the internal filters or an external filter to achieve EMC category C2. If an external filter is used to achieve EMC category C3, the maximum cable length per motor is 50 m.
- Permissible cables:
  - 16 mm<sup>2</sup>, Class 5 (finely stranded, PVC-insulated) H07V-K + H07V2-K according to EN 50525-2-31
  - HELUTHERM 145: 16 mm<sup>2</sup>, Class 5 (finely stranded, crosslinked polyolefin-copolymer, halogen-free) [www.helukabel.com](http://www.helukabel.com)
  - External diameter 6.7 mm to 8.1 mm
 Permissible cables (UL approval):
  - AWG 6, copper cable with PVC insulation, with or without nylon jacket, 19 strands
  - Types: MTW, THHW, THW, THW-2, THHN, THWN-2, TW, TWN
  - CSA types: TW, TWU, TWN75, TW75, TWU75, T90, no compressed conductors

6SL3255-0AA00-5AA0



## Order overview

## Accessories for MOTION-CONNECT connection systems

## OCC extension cables

Description	Cross-section mm <sup>2</sup>	For motor	OCC extension cable (for length code, see SINAMICS S210 drive system table) Article No.
<b>Pre-assembled OCC extension cable MOTION-CONNECT 500</b>	0.38	1FK2102, 1FK2.03	<b>6FX5002-8QE04-1</b> ■■■■
	0.75	1FK2.04, 1FK2.05	<b>6FX5002-8QE08-1</b> ■■■■
	1.5	1FK2.06, 1FK2.08, 1FK2.10	<b>6FX5002-8QE11-1</b> ■■■■
	2.5 <sup>2)</sup>	1FK2.06, 1FK2.08, 1FK2.10	<b>6FX5002-8QE21-1</b> ■■■■
<b>Pre-assembled OCC extension cable MOTION-CONNECT 800PLUS</b>	0.38	1FK2102, 1FK2.03	<b>6FX8002-8QE04-1</b> ■■■■
	0.75	1FK2.04, 1FK2.05	<b>6FX8002-8QE08-1</b> ■■■■
	1.5	1FK2.06, 1FK2.08, 1FK2.10	<b>6FX8002-8QE11-1</b> ■■■■
	2.5 <sup>2)</sup>	1FK2.06, 1FK2.08, 1FK2.10	<b>6FX8002-8QE21-1</b> ■■■■
<b>Pre-assembled OCC extension cable MOTION-CONNECT 500<sup>1)</sup></b> (male contacts fixed at the converter end, insulators and connector housing supplied with cable)	0.38	1FK2102, 1FK2.03	<b>6FX5012-8QE04-1</b> ■■■■
	0.75	1FK2.04, 1FK2.05	<b>6FX5012-8QE08-1</b> ■■■■
	1.5	1FK2.06, 1FK2.08, 1FK2.10	<b>6FX5012-8QE11-1</b> ■■■■
<b>Pre-assembled OCC extension cable MOTION-CONNECT 800PLUS<sup>1)</sup></b> (male contacts fixed at the converter end, insulators and connector housing supplied with cable)	0.38	1FK2102, 1FK2.03	<b>6FX8012-8QE04-1</b> ■■■■
	0.75	1FK2.04, 1FK2.05	<b>6FX8012-8QE08-1</b> ■■■■
	1.5	1FK2.06, 1FK2.08, 1FK2.10	<b>6FX8012-8QE11-1</b> ■■■■
	2.5 <sup>2)</sup>	1FK2.06, 1FK2.08, 1FK2.10	<b>6FX8012-8QE21-1</b> ■■■■

## OCC components for self assembly

Description	Cross-section mm <sup>2</sup>	For motor	OCC component (for length code, see SINAMICS S210 drive system table) Article No.
<b>Sold by the meter OCC line MOTION-CONNECT 500<sup>1)</sup></b>	0.38	1FK2102, 1FK2.03	<b>6FX5008-1BE04-1</b> ■■■■
	0.75	1FK2.04, 1FK2.05	<b>6FX5008-1BE08-1</b> ■■■■
	1.5	1FK2.06, 1FK2.08, 1FK2.10	<b>6FX5008-1BE11-1</b> ■■■■
	2.5 <sup>2)</sup>	1FK2.06, 1FK2.08, 1FK2.10	<b>6FX5008-1BE21-1</b> ■■■■

## OCC components for self assembly (continued)

Description	Cross-section mm <sup>2</sup>	For motor	OCC component (for length code, see SINAMICS S210 drive system table) Article No.	
<b>Sold by the meter OCC line MOTION-CONNECT 800PLUS<sup>1)</sup></b>	0.38	1FK2102, 1FK2.03	<b>6FX8008-1BE04-1</b> ■■■■	
	0.75	1FK2.04, 1FK2.05	<b>6FX8008-1BE08-1</b> ■■■■	
	1.5	1FK2.06, 1FK2.08, 1FK2.10	<b>6FX8008-1BE11-1</b> ■■■■	
	2.5 <sup>2)</sup>	1FK2.06, 1FK2.08, 1FK2.10	<b>6FX8008-1BE21-1</b> ■■■■	
<b>Motor-side SPEED-CONNECT connector<sup>1)</sup></b>				
	• M12	0.38	1FK2102, 1FK2.03	<b>6FX2003-0LU64</b>
	• M17	0.75	1FK2.04, 1FK2.05	<b>6FX2003-0LU54</b>
• M23	1.5 and 2.5	1FK2.06, 1FK2.08, 1FK2.10	<b>6FX2003-0LU34</b>	
<b>SPEED-CONNECT connector with external thread for extension cable<sup>1)</sup></b>				
	• M12	0.38	1FK2102, 1FK2.03	<b>6FX2003-0LA64</b>
	• M17	0.75	1FK2.04, 1FK2.05	<b>6FX2003-0LA54</b>
• M23	1.5 and 2.5	1FK2.06, 1FK2.08, 1FK2.10	<b>6FX2003-0LA34</b>	
<b>Converter-side Siemens IX signal connector<sup>1)</sup></b>	–	–	<b>6FX2003-0DE01</b>	
<b>Shield clamp</b> (Packing unit: 10 items)				
	• For pre-assembled cables with M12 and M17 connectors	0.38 and 0.75	–	<b>6FX2003-7EX10</b>
• For pre-assembled cables with M23 connectors	1.5 and 2.5	–	<b>6FX2003-7EX11</b>	

## Control cabinet bushings

Description	For motor	Article No.
<b>Mounting flange</b>	1FK2102, 1FK2.03	<b>6FX2003-7JX00</b>
	1FK2.04, 1FK2.05	<b>6FX2003-7HX00</b>
	1FK2.06, 1FK2.08, 1FK2.10	<b>6FX2003-7BX00</b>

## Recommended SIMATIC S7 controller

Further information about SIMATIC S7-1500 and SIMATIC S7-1500 T-CPU controllers is available in Catalog ST 70 and on the Internet at [www.siemens.com/simatic-s7-1500](http://www.siemens.com/simatic-s7-1500)

<sup>1)</sup> Available soon.

<sup>2)</sup> For increased requirement regarding routing type and ambient temperature. See tables in the section MOTION-CONNECT connection systems > More information > Current carrying capacity and derating factors.



## SINAMICS S210 starter kit

1

## Overview



The SINAMICS S210 starter kit with Extended Safety with Article No. 6SL3200-0AE61-0AA0 comprises

- a SINAMICS S210 servo converter, 230 V 1 AC, 400 W (Article No. 6SL3210-5HB10-4UF0)
- a SIMOTICS S-1FK2 servomotor, High Dynamic, shaft height 30, 400 W, without brake, shaft with feather key, with absolute encoder multiturn (Article No. 1FK2103-4AG00-1MA0)
- a corresponding One Cable Connection cable (OCC), 3 m (9.84 ft) (Article No. 6FX5002-8QN04-1AD0)
- a memory card with firmware V5.2 and Safety license (Extended Functions) (Article No. 6SL3054-4FC00-2BA0-Z F01)

The delivery quantity is limited to three per customer.

The SINAMICS S210 starter kit can be perfectly combined with the SIMATIC S7-1500 starter kit. In this way, Motion Control applications can be quickly and easily implemented.

For more information on SIMATIC S7-1500 starter kits, see: [www.siemens.com/s7-1500-starterkits](http://www.siemens.com/s7-1500-starterkits)

## Selection and ordering data

Description	Article No.
<b>SINAMICS S210 starter kit with Extended Safety</b> With SINAMICS S210 servo converter, SIMOTICS S-1FK2 servomotor (power rating 400 W), OCC cable (3 m (9.84 ft)) and memory card with Safety license (Extended Functions)	<b>6SL3200-0AE61-0AA0</b>

## SINAMICS S210 servo drive



<b>2/2</b>	<b>SINAMICS S210 servo drive</b>
2/2	Overview
2/4	Design
2/5	Function
2/5	Configuration
2/6	Integration
2/8	Selection and ordering data
2/10	Technical specifications
2/13	Dimensional drawings
2/14	Accessories
<b>2/15</b>	<b>Line-side components</b>
2/15	Line filters
2/16	Recommended line-side overcurrent protection devices
<b>2/17</b>	<b>DC link components</b>
2/17	External braking resistors
<b>2/18</b>	<b>Supplementary system components</b>
2/18	Memory cards

Detailed technical information on the SINAMICS S210 servo drive system is available on the Internet at [www.siemens.com/sinamics-s210/documentation](http://www.siemens.com/sinamics-s210/documentation)

In addition, the Drive Technology Configurator (DT Configurator) can be used on the Internet at the following address: [www.siemens.com/dt-configurator](http://www.siemens.com/dt-configurator)

## SINAMICS S210 servo drive

0.1 kW to 7 kW

### SINAMICS S210 servo drive

#### Overview

#### *SINAMICS S210 – the single-axis servo drive for highly dynamic applications*



SINAMICS S210, 1 AC series, frame sizes FSA to FSC



SINAMICS S210, 3 AC series, frame sizes FSA to FSC

The SINAMICS S210 servo converter is designed for connection to SIMOTICS S-1FK2 synchronous servomotors. PROFINET RT/IRT is available for connection to a higher-level control system. That allows, above all, SIMATIC S7 and SIMOTION to be used as controllers.

SINAMICS S210 is optimized for operation with SIMATIC S7-1500 and SIMATIC S7-1500T, which have their own positioning functionality. Therefore no additional basic positioner is integrated into the converter.

The converter works with a servo controller with or without Dynamic Servo Control (DSC) and has a torque setpoint limitation. A wide range of internal protection functions are included to protect the converter.

The status of the converter is indicated by two multi-color LEDs and a 7-segment display. Pending faults can be acknowledged with a button under the front cover.

The converter has a web server, which can be called via the service interface or via PROFINET from a web browser on a PC. Both commissioning and diagnostics can be performed through this. With the web server, the converter can be brought into operation in a few steps. As the motor data from the converter is read from the electronic type plate, they do not need to be parameterized. The PROFIdrive telegram is automatically accepted by the controller; so only the controller parameters have to be adjusted. This is simply done with the One Button Tuning function, which automatically determines the parameters.

In addition to easy commissioning directly via the web server of the converter, engineering is also possible with SINAMICS Startdrive and TIA Portal (as of V15.1). The tool for configuration, commissioning and diagnostics has been optimized with regard to user friendliness and the consistent utilization of the TIA Portal advantages of a shared work environment for PLC, HMI and drives (requires SINAMICS S210 firmware V5.2 or higher).

SIMOTICS S-1FK2 servomotors can be connected and operated via a One Cable Connection (OCC) line. Third-party motors cannot be connected because the converter requires the type plate data of the motor.

No additional components are required for controlling the motor holding brake as all the required components are integrated into the converter. In addition, no special power supply is required because the converter optimally sets the voltage for the brake internally. Thus, in combination with the 1FK2 motors, shortened opening and closing times of the brakes are also possible.

The converter can be operated optionally with a memory card. The card is inserted in the card slot behind the front cover. Firmware and drive parameters can be stored on the memory card, so that the converter can easily be replaced without any other aids. This memory card can also be used to perform series commissioning on multiple drives of identical type.

The card is available as an empty memory card or containing the latest drive firmware version. The memory card also contains the licenses for chargeable functions, such as the safety license for the Extended Safety Functions. To use these functions, a memory card containing the corresponding safety license must be permanently inserted.

If necessary, the converter contains an integrated braking resistor. As a result of the generous dimensioning of the resistor and the DC link capacities, an external braking resistor is only necessary to meet very high requirements. When operating a SINAMICS S210 servo converter with a supply voltage of 200 V to 240 V 3 AC, an external, intrinsically safe braking resistor is always required.

For the 3 AC series, DC link coupling of up to six devices is possible. Thus, the energy that is generated when braking axes can be used for accelerating other axes. This conserves energy and reduces the amount of heat dissipated via the braking resistors.

The converter also features an integrated line filter. For the 1 AC series, it satisfies category C2 for cable lengths up to 10 m and category C3 for cable lengths up to 25 m. With an optional external line filter, cable lengths of up to 25 m are also possible with category C2 and up to 50 m with category C3. For the 3 AC series, category C3 is achieved for cable lengths up to 25 m. For requirements that go beyond this, an external line filter is required.

**Overview**

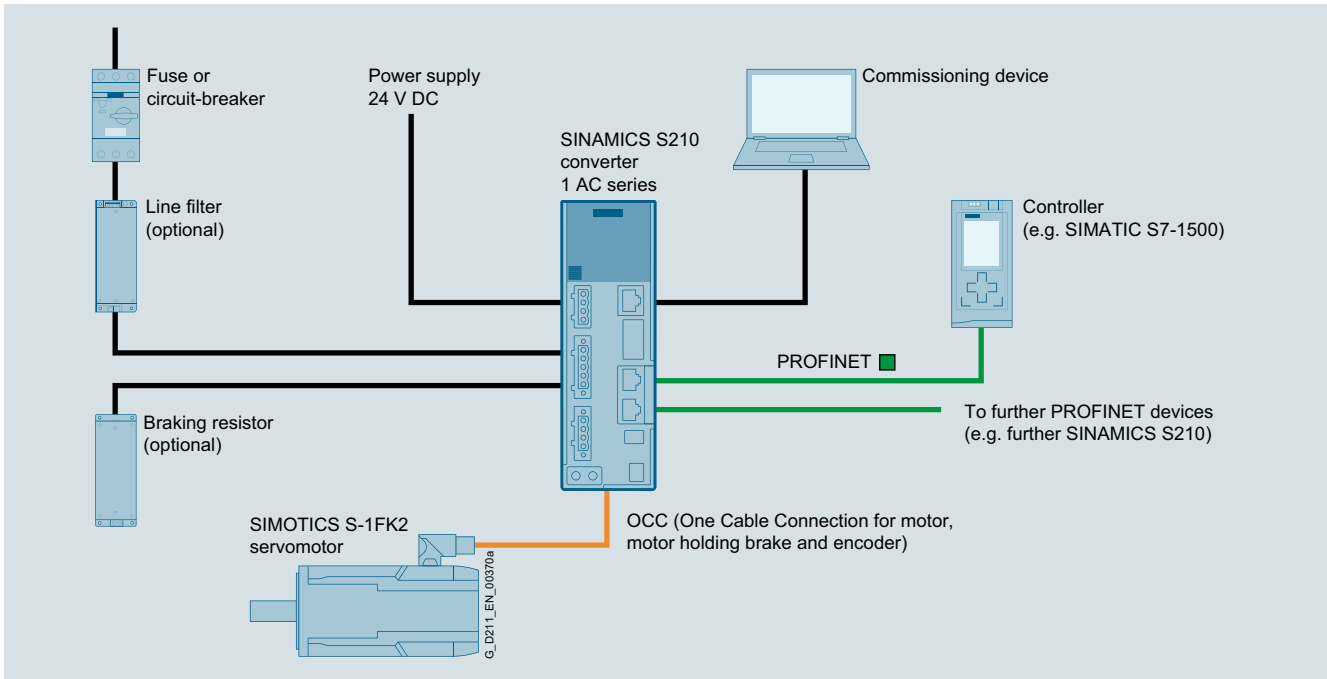

SINAMICS S210 drive system, 1 AC series with optional components

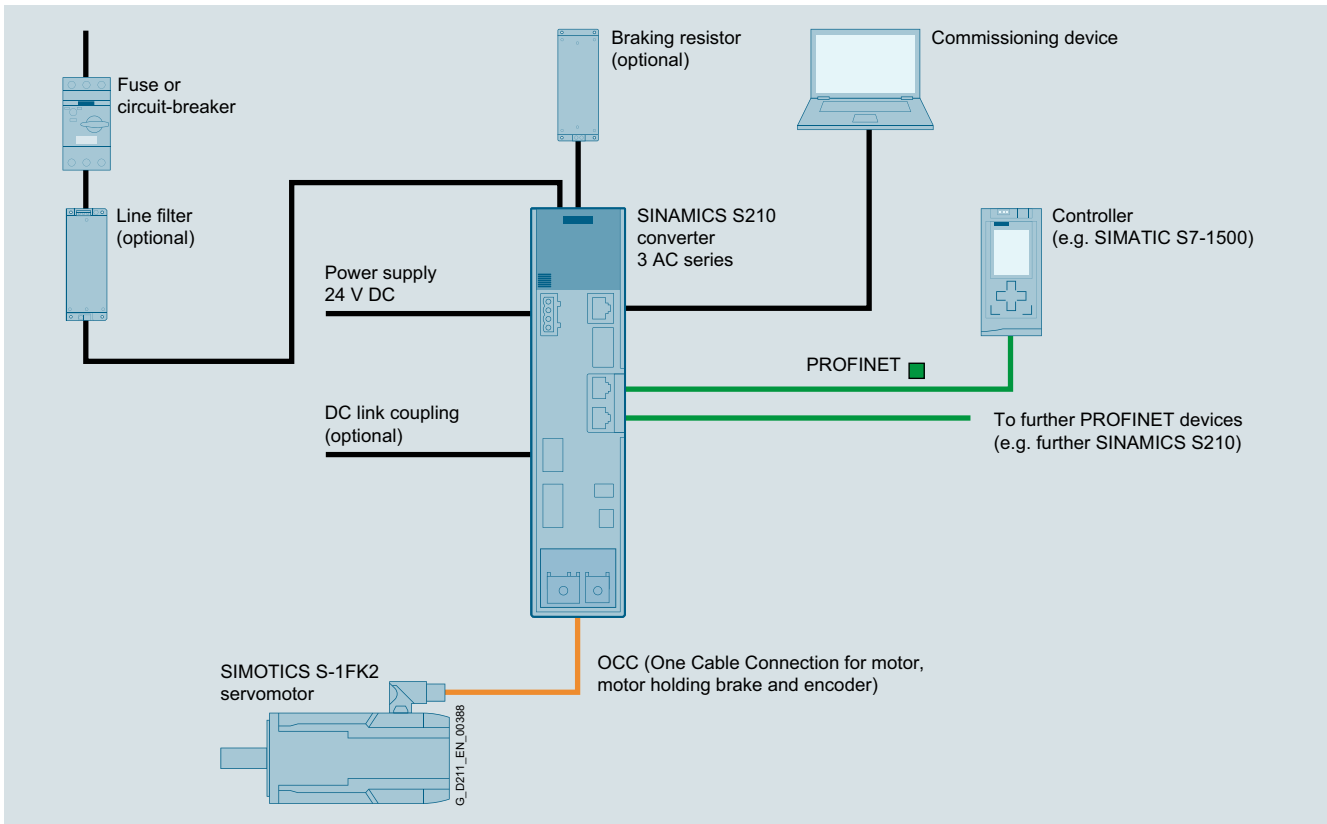

SINAMICS S210 drive system, 3 AC series with optional components

## SINAMICS S210 servo drive

0.1 kW to 7 kW

### SINAMICS S210 servo drive

#### Design

The single-axis AC/AC converter contains a power unit and a Control Unit for the powerful communication, open and closed-loop control functions.

The SINAMICS S210 servo converter features the following connections and interfaces as standard:

- Fieldbus interface
  - 1 PROFINET interface with two ports (RJ45 sockets) with PROFINET V4 profile
- 1 service interface for Ethernet communications with a service PC
- One Cable Connection (OCC)
  - 1 communications connector for communication with the encoder of the SIMOTICS S-1FK2 motor
  - 1 motor power connector for the power conductors of the SIMOTICS S-1FK2 motor
  - 1 brake connection for the conductors of the motor holding brake of the SIMOTICS S-1FK2 motor
- 1 connection for the electronic power supply via the 24 V DC supply connector (supply can be looped through connectors for several SINAMICS S210)
- 1 connection for the line voltage and an external braking resistor (braking resistor optional, for the 3 AC series via a separate connector). When connecting to 200 V to 240 V 3 AC, an external, intrinsically safe braking resistor is always required.
- 1 connection for the DC link coupling (optional, only for the 3 AC series)
- Digital inputs
  - 1 fail-safe digital input (isolated) for controlling STO and SS1 via terminals
  - 2 high-speed digital inputs for measuring probe or reference marks
  - 1 digital input for monitoring the temperature of an external braking resistor
- 1 slot for a memory card on which the firmware, parameters and licenses can be stored
- 1 display with 3-digit, 7-segment display for indicating faults and two status LEDs
- 1 button for acknowledging errors

#### DC link coupling (only 3 AC series)

For devices of the 3 AC series, the DC links of up to six converters can be coupled. Thus, energy balancing between the axes is possible and energy produced during braking can be used by other axes for accelerating. This is not only efficient but also reduces the dissipated heat in the control cabinet, because the energy that is produced no longer has to be converted to heat in the braking resistor. For DC link coupling, the line side must also be coupled (AC bus).

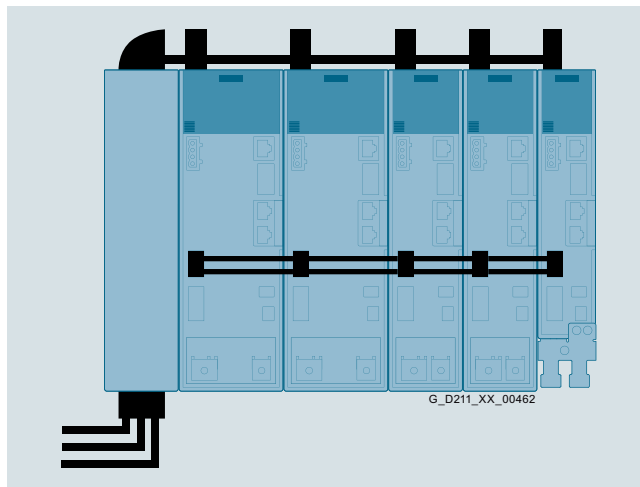

SINAMICS S210, 3 AC series, one line filter plus five servo converters, AC coupling and DC link coupling



## Function

<b>Closed-loop control</b>	Servo control with DSC
<b>Control functions</b>	Speed control with encoder Dynamic Servo Control (DSC) Torque setpoint limitation Current controller and current controller adaptation suitably adjusted for SIMOTICS S-1FK2 servomotors One Button Tuning with moment of inertia estimator and reference model Local measuring probe Simple brake control Direction reversal without changing the setpoint channel Travel to fixed stop Vertical axis Speed controller adaptation Thermal monitoring for power unit and servomotor High-performance brake control
<b>Protective functions</b>	Undervoltage DC link voltage Overvoltage DC link voltage Overcurrent power unit Overcurrent motor Overload power unit ( $I^2t$ ) Short-circuit Ground fault Temperature rise servomotor Temperature rise power unit
<b>Safety Integrated</b>	Safe Torque OFF (STO) Safe Brake Control (SBC) Safe Stop 1 (SS1) Safe Stop 2 (SS2) <sup>1)</sup> Safe Operating Stop (SOS) <sup>1)</sup> Safely-Limited Speed (SLS) <sup>1)</sup> Safe Speed Monitor (SSM) <sup>1)</sup> Safe Direction (SDI) <sup>1)</sup> Safely-Limited Acceleration (SLA) <sup>1)</sup> Safe Brake Test (SBT) diagnostic function <sup>1)</sup>
<b>Commissioning</b>	Identification of the SIMOTICS S-1FK2 motors via the electronic type plate Automatic controller optimization

## Configuration

The following electronic configuring aids and engineering tools are available for the SINAMICS S210 servo converters:

### **Drive Technology Configurator (DT Configurator) within the CA 01**

The Interactive Catalog CA 01 – the offline Industry Mall of Siemens – contains over 100000 products with approximately 5 million possible drive system product variants. The Drive Technology Configurator (DT Configurator) has been developed to facilitate selection of the correct motor and/or converter from the wide spectrum of drives. It is integrated as a selection tool in the Interactive Catalog CA 01.

### **Online DT Configurator**

In addition, the DT Configurator can be used on the Internet without requiring any installation. The DT Configurator can be found in the Siemens Industry Mall at the following address:  
[www.siemens.com/dt-configurator](http://www.siemens.com/dt-configurator)

### **Drive dimensioning of the SINAMICS S210 servo drive system with the TIA Selection Tool**

The SINAMICS S210 servo drive system is easily configured with the TIA Selection Tool under the Drive Dimensioning plug-in. It provides support when selecting the hardware and firmware components necessary to implement a drive task. The plug-in encompasses the configuration of the entire drive system and allows the handling of individual drives.

- Intuitive user interface, menu-based operation and help
- Configuration of the SINAMICS S210 servo drive system
- Adjustable traversing cycles and various mechanical systems integrated for single-axis applications
- Interface to the TIA Portal and Industry Mall

The TIA Selection Tool is available for free on the Internet at  
[www.siemens.com/tia-selection-tool-standalone](http://www.siemens.com/tia-selection-tool-standalone)

#### Note:

Multi-axis applications and integration into the online version available soon.

### **SINAMICS web server for SINAMICS S210**

The converter can be brought easily and quickly into operation and optimized with the web server. Additional software does not need to be installed as access comes directly from a web browser.

You can find further information about the web server for SINAMICS S210 in the Engineering tools section.

### **SINAMICS Startdrive commissioning tool (TIA Portal)**

SINAMICS Startdrive is a tool for configuring, commissioning and diagnosing the SINAMICS converter family that is integrated into TIA Portal (V15.1 or higher).

The SINAMICS Startdrive has been optimized with regard to user friendliness and consistent use of the TIA Portal benefits of a common working environment for PLC, HMI and drives. SINAMICS firmware V5.2 or higher is required for SINAMICS S210.

The SINAMICS Startdrive Advanced license is required for the Safety Integrated acceptance test.

The SINAMICS Startdrive commissioning tool is available free on the Internet at  
[www.siemens.com/startdrive](http://www.siemens.com/startdrive)

You can find further information on the SINAMICS Startdrive commissioning tool in the section Engineering tools.

<sup>1)</sup> Available in firmware V5.1 SP1 and higher. The Extended Functions require a Safety license.

# SINAMICS S210 servo drive

0.1 kW to 7 kW

## SINAMICS S210 servo drive

### Integration

2

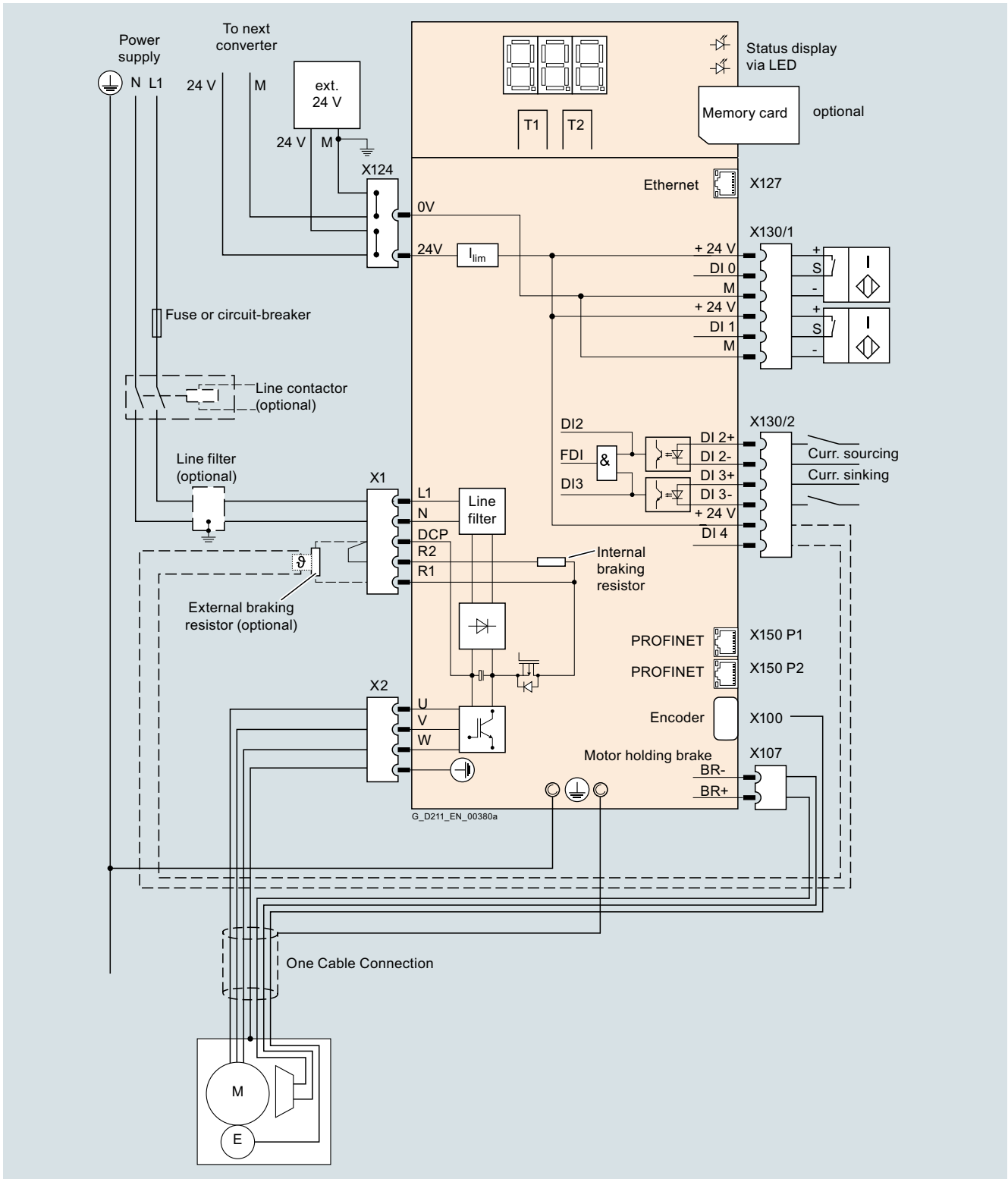

Connection example SINAMICS S210 servo converter, 1 AC series

**Integration**

2

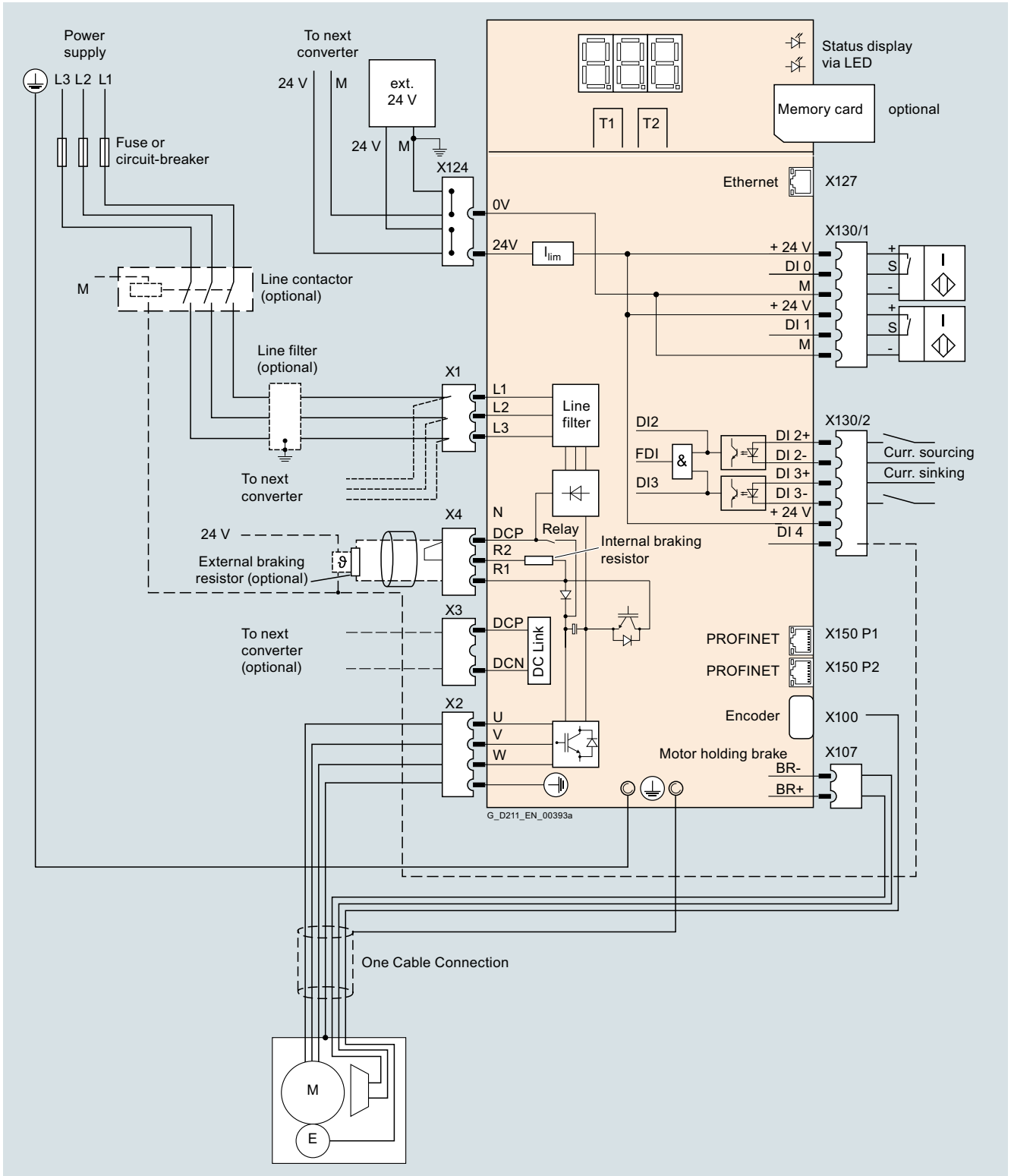

Connection example SINAMICS S210 servo converter, 3 AC series

# SINAMICS S210 servo drive



0.1 kW to 7 kW

## SINAMICS S210 servo drive

### Selection and ordering data



2

Description	Frame size	Article No.
<b>200 ... 240 V 1 AC</b>		
<b>SINAMICS S210 servo converters</b> with shield plate and push-in connectors without memory card The shield clamp is included in the scope of delivery of the MOTION-CONNECT cable.		
 <ul style="list-style-type: none"> <li>• 0.1 kW</li> </ul>	FSA	<b>6SL3210-5HB10-1UF0</b>
	FSA	<b>6SL3210-5HB10-2UF0</b>
 <ul style="list-style-type: none"> <li>• 0.4 kW</li> </ul>	FSB	<b>6SL3210-5HB10-4UF0</b>
	FSC	<b>6SL3210-5HB10-8UF0</b>
 <ul style="list-style-type: none"> <li>• 0.75 kW</li> </ul>	FSC	<b>6SL3210-5HB10-8UF0</b>

Description	Frame size	Article No.
<b>200 ... 480 V 3 AC</b>		
<b>SINAMICS S210 servo converters</b> with shield plate (for FSA only) and push-in connectors without memory card The shield clamp is included in the scope of delivery of the MOTION-CONNECT cable.		
 <ul style="list-style-type: none"> <li>• 0.4 kW</li> <li>• 0.75 kW</li> <li>• 1 kW</li> </ul>	FSA	<b>6SL3210-5HE10-4UF0</b>
	FSA	<b>6SL3210-5HE10-8UF0</b>
	FSA	<b>6SL3210-5HE11-0UF0</b>
 <ul style="list-style-type: none"> <li>• 1.5 kW</li> <li>• 2 kW</li> </ul>	FSB	<b>6SL3210-5HE11-5UF0</b>
	FSB	<b>6SL3210-5HE12-0UF0</b>
 <ul style="list-style-type: none"> <li>• 3.5 kW</li> <li>• 5 kW</li> <li>• 7 kW</li> </ul>	FSC	<b>6SL3210-5HE13-5UF0</b>
	FSC	<b>6SL3210-5HE15-0UF0</b>
	FSC	<b>6SL3210-5HE17-0UF0</b>





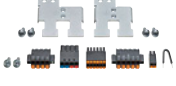

**When operating a SINAMICS S210 servo converter with a supply voltage of 200 V to 240 V 3 AC, an external, intrinsically safe braking resistor is always required.**

**Selection and ordering data**
**Accessories**

Description	Article No.
 <p><b>SINAMICS SD card (optional)</b> 512 MB</p> <p>The parameter assignment, firmware and licenses for a converter can be stored on this memory card.</p> <p>Firmware V5.2 or higher is required for the 3 AC series.</p> <ul style="list-style-type: none"> <li>• Empty</li> <li>• With firmware V5.1</li> <li>• With firmware V5.1 SP1</li> <li>• With firmware V5.1 SP1 and Safety license (Extended Functions)</li> <li>• With firmware V5.2</li> <li>• With firmware V5.2 and Safety license (Extended Functions)</li> <li>• With firmware V5.2 SP3 <b>NEW</b></li> <li>• With firmware V5.2 SP3 and Safety license (Extended Functions) <b>NEW</b></li> </ul>	<p><b>6SL3054-4AG00-2AA0</b>  <b>6SL3054-4FB00-2BA0</b>  <b>6SL3054-4FB10-2BA0</b>  <b>6SL3054-4FB10-2BA0-Z F01</b></p> <p><b>6SL3054-4FC00-2BA0</b>  <b>6SL3054-4FC00-2BA0-Z F01</b></p> <p><b>6SL3054-4FC30-2BA0</b> <b>NEW</b></p> <p><b>6SL3054-4FC30-2BA0-Z F01</b> <b>NEW</b></p>
<p><b>Safety license</b> (Extended Functions) <sup>1)</sup></p> <ul style="list-style-type: none"> <li>• CoL in paper form</li> <li>• CoL in electronic form <b>NEW</b></li> </ul>	<p><b>6SL3074-0AA10-0AA0</b>  <b>6SL3074-0AA10-0AH0</b> <b>NEW</b></p>
 <p><b>PROFINET patch cable</b></p> <p>For the networking of concatenated converters</p> <p>Industrial Ethernet TP cord, CAT 6 A, twisted pair line 4 × 2 cores, pre-assembled with two RJ45 connectors</p> <ul style="list-style-type: none"> <li>• 0.3 m (0.98 ft)</li> <li>• 0.5 m (1.64 ft)</li> </ul>	<p><b>6XV1870-3QE30</b>  <b>6XV1870-3QE50</b></p>
<b>Only for the 1 AC series</b>	
 <p><b>Line filter</b> <b>NEW</b></p> <p>With this line filter, Category C2 for cable lengths up to 25 m (82 ft), Category C3 for cable lengths up to 50 m (164 ft) acc. to EN 61800-3 can be achieved.</p>	<p><b>6SL3203-0BB21-8VA1</b> <b>NEW</b></p>
 <p><b>Replacement connector set</b></p> <p>For frame sizes FSA, FSB and FSC</p> <p>With a connector set, as in the scope of delivery, and two shield plates</p>	<p><b>6SL3260-2DB00-0AA0</b></p>

<sup>1)</sup> Extended function for an existing memory card (firmware V5.1 SP1 or higher). The memory card is not included in the scope of delivery. The Safety license can also be ordered together with a memory card (see above). With a CoL in electronic form, the license is supplied as a PDF file. Notification of this with a download link is received by email. For further information, see section Supplementary system components > Memory cards.

<sup>2)</sup> The data is applicable for the complete cable length of the motors, whose associated converters are coupled with one another via an AC coupling or through the DC link. The maximum cable length per motor is 25 m using the internal filters or an external filter to achieve EMC category C2. If an external filter is used to achieve EMC category C3, the maximum cable length per motor is 50 m.

Description	Article No.
<b>Only for the 3 AC series</b>	
 <p><b>Line filter</b></p> <p>With these line filters, Category C2 for cable lengths up to 25 m (82 ft), Category C3 for cable lengths up to 50 m (164 ft) acc. to IEC 61800-3 can be achieved.</p> <p>When connected via a DC link, a total cable length of up to 100 m (328 ft) with Category C2 and up to 250 m (820 ft) with Category C3 is possible <sup>2)</sup></p> <ul style="list-style-type: none"> <li>• ≤ 35 A <b>NEW</b></li> <li>• ≤ 65 A <b>NEW</b></li> </ul>	<p><b>6SL3203-0BE23-5HA0</b>  <b>6SL3203-0BE26-5HA0</b> <b>NEW</b></p>
 <p><b>Connector set AC bus and DC link</b></p> <p>For coupling the DC link and the line infeed</p> <p>Scope of delivery: 1 AC bus connector, 1 DC link connector, 2 cover caps</p> <p>The AC bus connector replaces the push-in connector included in the scope of delivery of the converter.</p> <p>Wiring is performed with conventional 16 mm<sup>2</sup> cable (not included in scope of delivery) <sup>3)</sup></p>	<p><b>6SL3260-2DC00-0AA0</b></p>
 <p><b>Connector set AC bus individual</b></p> <p>For coupling the line infeed</p> <p>Scope of delivery: 1 AC bus connector, 1 cover cap</p> <p>This connector replaces the push-in connector included in the scope of delivery of the converter. Wiring is performed with conventional 16 mm<sup>2</sup> cable (not included in scope of delivery) <sup>3)</sup></p>	<p><b>6SL3260-2DC10-0AA0</b></p>
 <p><b>External braking resistors for 200 ... 240 V 3 AC</b></p> <p>For a supply voltage of 200 V to 240 V 3 AC, an external, intrinsically safe braking resistor is always required for each converter</p> <ul style="list-style-type: none"> <li>• 100 W, 47 Ω for <b>NEW</b> FSA and FSB</li> <li>• 240 W, 14 Ω for <b>NEW</b> FSC</li> </ul>	<p><b>GXK:BWG250047TS-190</b> <b>NEW</b></p> <p><b>GXK:BWG600014TS-190</b> <b>NEW</b></p>
 <p><b>Replacement connector set</b></p> <p>For frame sizes FSA, FSB and FSC</p> <p>With a connector set, as in the scope of delivery, and one shield plate (for FSA)</p>	<p><b>6SL3260-2DB10-0AA0</b></p>
 <p><b>Replacement fan</b></p> <p>Incl. support</p> <ul style="list-style-type: none"> <li>• Frame size FSA</li> <li>• Frame size FSB</li> <li>• Frame size FSC</li> </ul>	<p><b>6SL3260-0AA00-0AA0</b>  <b>6SL3260-0AB00-0AA0</b>  <b>6SL3260-0AC00-0AA0</b></p>

<sup>3)</sup> Permissible cables:

- 16 mm<sup>2</sup>, Class 5 (finely stranded, PVC-insulated) H07V-K + H07V2-K according to EN 50525-2-31
- HELUTHERM 145: 16 mm<sup>2</sup>, Class 5 (finely stranded, crosslinked polyolefin-copolymer, halogen-free) ([www.helukabel.com](http://www.helukabel.com))
- External diameter 6.7 mm to 8.1 mm

Permissible cables (UL approval):

- AWG 6, copper cable with PVC insulation, with or without nylon jacket, 19 strands
- Types: MTW, THHW, THW, THW-2, THHN, THWN-2, TW, TWN
- CSA types: TW, TWU, TWN75, TW75, TWU75, T90, no compressed conductors

**SINAMICS S210 servo drive**

0.1 kW to 7 kW

**SINAMICS S210 servo drive****Technical specifications**

Unless explicitly specified otherwise, the following technical specifications are valid for all SINAMICS S210 servo converters.

**General technical specifications****Mechanical specifications****Vibratory load**

- Transport <sup>1)</sup> acc. to IEC 60721-3-2: 1997
- Operation acc. to IEC 60721-3-3: 2002
  - Test values according to IEC/EN 60068-2-6

Class 2M3  
Class 3M2  
Test Fc (sinusoidal)

- 9 ... 18 Hz: 1.5 mm deflection amplitude
- 18 Hz ... 200 Hz: 2 × g acceleration amplitude
- 10 frequency cycles per axis

**Shock load**

- Transport <sup>1)</sup> acc. to IEC 60721-3-2: 1997
- Operation acc. to IEC 60721-3-3: 2002
  - Test values according to IEC/EN 60068-2-27

Class 2M3  
Class 3M2  
Test Ea (semisinusoidal)

- 5 × g peak acceleration
- 30 ms duration
- 3 shocks in all three axes in both directions

**Environmental conditions****Protection class**

According to IEC/EN 61800-5-1

Class I (with protective bonding circuit) and class III (PELV or SELV)

**Degree of protection**

According to IEC/EN 60529

IP20  
Mounting in control cabinet necessary**Permissible ambient temperature (air) in operation**

0 ... 50 °C (32 ... 122 °F)

**Installation altitude**

Up to max. 4000 m (13123 ft) (IEC/EN/UL), up to max. 2000 m (6562 ft) (CSA)

- Up to 1000 m (3281 ft) above sea level without derating
- As from 1000 m (3281 ft) derating 10 % of current or 5 K per 1000 m (3281 ft)
- For 1 AC devices, an isolating transformer is required from 2000 m (6562 ft)

**Climatic environmental conditions**

- Storage <sup>2)</sup> acc. to IEC 60721-3-1: 1997
- Transport <sup>1)</sup> acc. to IEC 60721-3-2: 1997
- Operation acc. to IEC 60721-3-3: 2002

Class 1K4  
-25 ... +55 °C (-13 ... +131 °F)

Class 2K4  
-40 ... +70 °C (-40 ... +158 °F)  
Max. air humidity: 95 % at 40 °C (104 °F)  
Better than class 3K3

0 ... 50 °C (32 ... 122 °F)  
Relative air humidity: 5 ... 95 %  
Condensation, splashwater, and ice formation not permitted (IEC/EN 60204, Part 1)

**Environmental class/harmful chemical substances**

- Storage <sup>2)</sup> acc. to IEC 60721-3-1: 1997
- Transport <sup>1)</sup> acc. to IEC 60721-3-2: 1997
- Operation acc. to IEC 60721-3-3: 2002

Class 1C2  
Class 2C2  
Class 3C2

**Organic/biological influences**

- Storage <sup>2)</sup> acc. to IEC 60721-3-1: 1997
- Transport <sup>1)</sup> acc. to IEC 60721-3-2: 1997
- Operation acc. to IEC 60721-3-3: 2002

Class 1B2  
Class 2B2  
Class 3B2

**Degree of pollution**

According to IEC/EN 61800-5-1

2

**Standards****Certificates of suitability**

CE, cULus (UL File No. E355661 for 1 AC series, E192450 for 3 AC series), RCM, EAC, KC (only for 1 AC series, available soon for 3 AC series)

**Functional safety**

- SIL 2 according to IEC 61508 parts 1 to 3 (2010) and IEC 61800-5-2 (2016)
- PL d according to ISO 13849 part 1 (2015)
- Category 3 according to IEC 60204 (2007)

<sup>1)</sup> In transport packaging.

<sup>2)</sup> In product packaging.

**Technical specifications**

Line voltage 200 ... 240 V 1 AC		SINAMICS S210 servo converters, 1 AC series			
		6SL3210-5HB10-1UF0	6SL3210-5HB10-2UF0	6SL3210-5HB10-4UF0	6SL3210-5HB10-8UF0
<b>Line supply connection</b>					
• Supply voltage		200 ... 240 V 1 AC ±10 %			
• Line frequency	Hz	50/60			
• Conductor cross-section, max.	mm <sup>2</sup>	2.5			
• Line system configuration		Grounded TN/TT networks and ungrounded IT networks			
<b>Rated current</b>	A	1.4	2.7	5	9.3
<b>Inrush current</b>	A	8	8	8	8
<b>Power loss</b>	W	15.7	23.2	38.5	71.1
<b>Electronic power supply</b>					
• Voltage		24 V -15 % ... +20 %			
• Power requirement, max.	A	0.8 without brake <a href="#">For current consumption of the brake, see section SIMOTICS S-1FK2 servomotors &gt; Technical specifications &gt; Holding brake, page 3/10</a>			
• Conductor cross-section, max.	mm <sup>2</sup>	2.5			
<b>Output</b>					
• Rated power 230 V	kW	0.1	0.2	0.4	0.75
• Rated current	A	0.8	1.4	2.4	4.4
• Output current, max.	A	3.1	4.8	8.7	16
<b>Pulse frequency power unit</b>	kHz	8			
<b>Output frequency</b>	Hz	0 ... 550			
<b>Line filter</b>		Integrated, category C2 (up to 10 m (32.8 ft) cable length), category C3 (up to 25 m (82.0 ft) cable length)			
<b>Braking resistor</b>		Without <sup>1)</sup>	Integrated	Integrated	Integrated
<b>Digital inputs <sup>2)</sup></b>					
• Fast inputs for measuring probes, reference marks, temperature monitoring, external braking resistor		3			
- Low level		-30 V ... +5 V and ≤ 2 mA			
- High level		15 V ... 30 V			
- Current consumption	mA	6			
- Delay time, typ., L → H	µs	5			
- Delay time, typ., H → L	µs	50			
- Galvanic isolation		No			
• Fail-safe input		1			
- Low level		-30 V ... +5 V and ≤ 2 mA			
- High level		15 V ... 30 V			
- Current consumption	mA	5			
- Delay time, typ., L → H	µs	50			
- Delay time, typ., H → L	µs	100			
- Galvanic isolation		Yes			
• Conductor cross-section, max.	mm <sup>2</sup>	1.5			
<b>Cooling</b>		Convection (without fan)			
<b>Frame size</b>		FSA		FSB	FSC
<b>Dimensions</b>					
• Width	mm (in)	45 (1.77)		55 (2.17)	74.5 (2.93)
• Height	mm (in)	170 (6.69)		170 (6.69)	170 (6.69)
• Depth	mm (in)	170 (6.69)		170 (6.69)	195 (7.68)
<b>Weight, approx.</b>	kg (lb)	1.1 (2.43)		1.2 (2.65)	1.9 (4.19)

<sup>1)</sup> An internal braking resistor is not required for normal operation on account of the available DC link capacity.

<sup>2)</sup> The specified delay times refer to the hardware. The actual reaction time depends on the time slot in which the digital input is processed.

# SINAMICS S210 servo drive

0.1 kW to 7 kW

## SINAMICS S210 servo drive

### Technical specifications

Line voltage 200 ... 480 V 3 AC		SINAMICS S210 servo converters, 3 AC series								
		6SL3210-5HE10-4UF0	6SL3210-5HE10-8UF0	6SL3210-5HE11-0UF0	6SL3210-5HE11-5UF0	6SL3210-5HE12-0UF0	6SL3210-5HE13-5UF0	6SL3210-5HE15-0UF0	6SL3210-5HE17-0UF0	
<b>Line supply connection</b> <ul style="list-style-type: none"> <li>Supply voltage</li> <li>Line frequency</li> <li>Conductor cross-section, max.</li> <li>Line system configuration</li> </ul>	Hz	200 ... 480 V 3 AC ±10 %								
	mm <sup>2</sup>	50/60								
		6								
		Grounded TN/TT networks, ungrounded IT networks and networks with grounded line conductor only with an isolating transformer								
<b>Rated current</b>	A	1.6	2.8	3.8	6	7.5	12.5	15	17.9	
<b>Inrush current</b>	A	4.3	4.3	4.3	8.6	8.6	27.8	27.8	27.8	
<b>Power loss</b>	W	69	81	94	114	131	167	191	204	
<b>Electronic power supply</b> <ul style="list-style-type: none"> <li>Voltage</li> <li>Power requirement, max.</li> </ul>	A	24 V -15 % ... +20 %								
		1.2 without brake								
		For current consumption of the brake, see section SIMOTICS S-1FK2 servomotors > Technical specifications > Holding brake, page 3/10								
<ul style="list-style-type: none"> <li>Conductor cross-section, max.</li> </ul>	mm <sup>2</sup>	2.5								
<b>Output</b> <ul style="list-style-type: none"> <li>Rated power</li> <li>- 400 V</li> <li>- 240 V</li> <li>Rated current</li> <li>Output current, max.</li> </ul>	kW	0.4	0.75	1	1.5	2	3.5	5	7	
	kW	0.24	0.45	0.6	0.9	1.2	2.1	3	4.2	
	A	1.2	2.3	3	5	7	9	12	15	
	A	4.2	7.6	10.9	19	24	33	44	55	
<b>Pulse frequency power unit</b>	kHz	8								
<b>Output frequency</b>	Hz	0 ... 550								
<b>Line filter</b>		Category C3 (up to 25 m (82.0 ft) cable length for a single axis, for DC link coupling see Accessories/line filters)								
<b>Braking resistor</b>		Integrated, when connecting to 200 V ... 240 V 3 AC, an external, intrinsically safe braking resistor is always required.								
<b>Digital inputs <sup>1)</sup></b> <ul style="list-style-type: none"> <li>Fast inputs for measuring probes, reference marks, temperature monitoring, external braking resistor</li> <li>- Low level</li> <li>- High level</li> <li>- Current consumption</li> <li>- Delay time, typ., L → H</li> <li>- Delay time, typ., H → L</li> <li>- Galvanic isolation</li> <li>Fail-safe input</li> <li>- Low level</li> <li>- High level</li> <li>- Current consumption</li> <li>- Delay time, typ., L → H</li> <li>- Delay time, typ., H → L</li> <li>- Galvanic isolation</li> <li>Conductor cross-section, max.</li> </ul>		3								
			-30 V ... +5 V and ≤ 2 mA							
			15 V ... 30 V							
		mA	6							
		μs	5							
		μs	50							
			No							
			1							
			-30 V ... +5 V and ≤ 2 mA							
			15 V ... 30 V							
		mA	5							
		μs	50							
		μs	100							
		Yes								
	mm <sup>2</sup>	1.5								
<b>Cooling</b>		Air cooling with integrated fan								
<b>Frame size</b>		FSA			FSB		FSC			
<b>Dimensions</b> <ul style="list-style-type: none"> <li>Width</li> <li>Height</li> <li>Depth</li> </ul>	mm (in)	50 (1.97)			70 (2.76)		105 (4.13)			
	mm (in)	231 (9.09)			280 (11.0)		280 (11.0)			
	mm (in)	223 (8.78)			223 (8.78)		223 (8.78)			
<b>Weight, approx.</b>	kg (lb)	2.1 (4.63)			3.3 (7.28)		5 (11.03)			

<sup>1)</sup> The specified delay times refer to the hardware. The actual reaction time depends on the time slot in which the digital input is processed.



**Dimensional drawings**

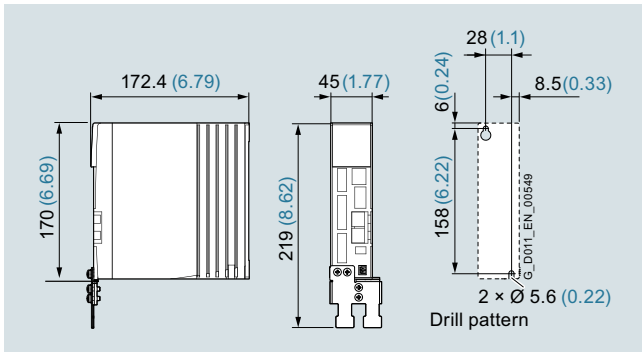

Dimensional drawing SINAMICS S210, frame size FSA, 1 AC series

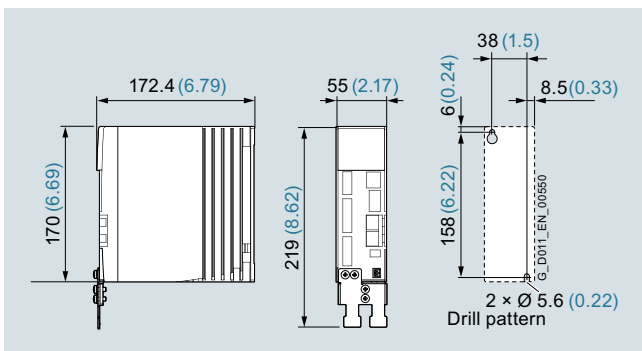

Dimensional drawing SINAMICS S210, frame size FSB, 1 AC series

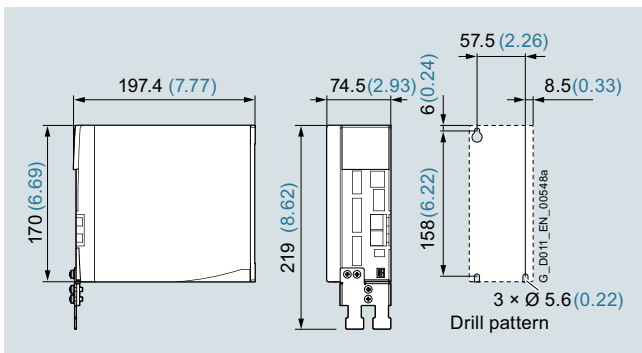

Dimensional drawing SINAMICS S210, frame size FSC, 1 AC series

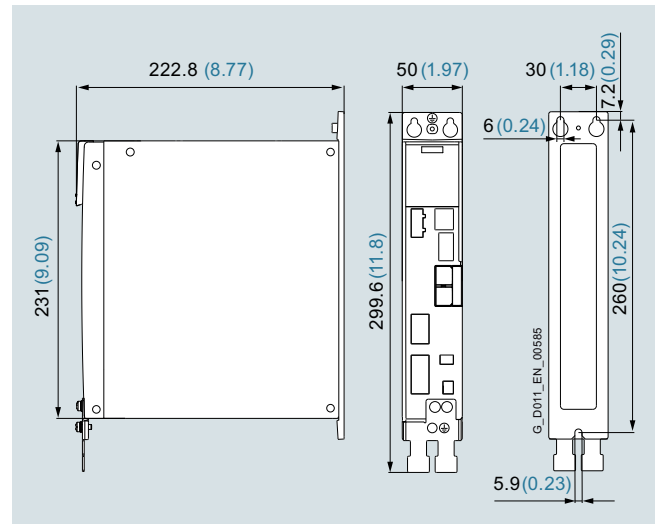

Dimensional drawing SINAMICS S210, frame size FSA, 3 AC series

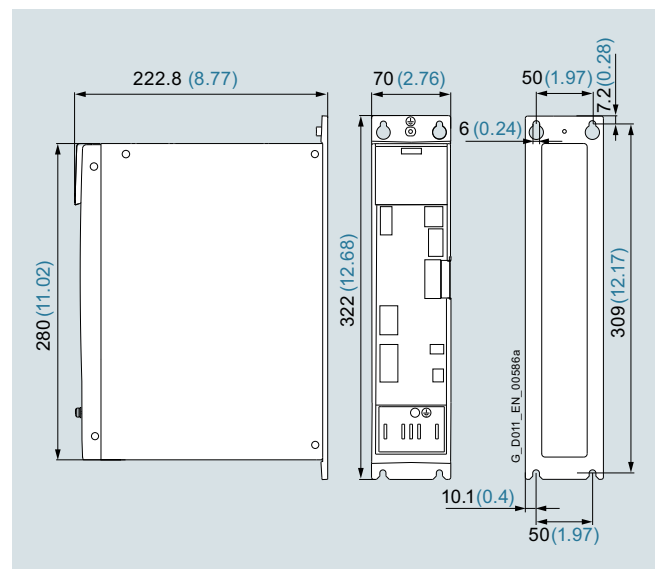

Dimensional drawing SINAMICS S210, frame size FSB, 3 AC series

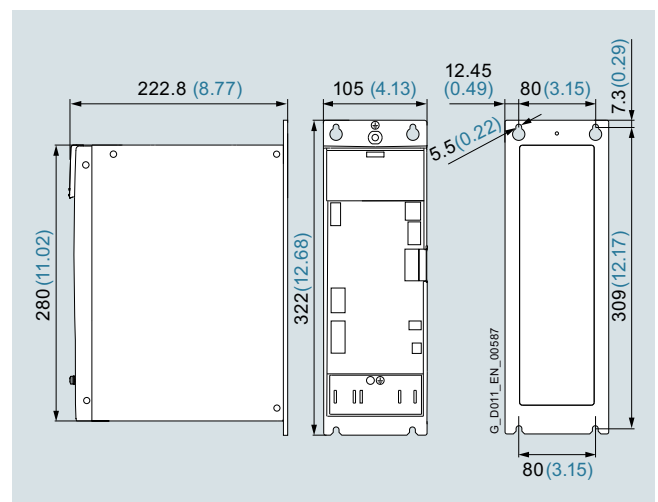

Dimensional drawing SINAMICS S210, frame size FSC, 3 AC series

All dimensions in mm (values in brackets are in inches).

With the OCC motor connection cable connected, the overall depth increases by 56.6 mm (2.28 inches).

## SINAMICS S210 servo drive

0.1 kW to 7 kW

### SINAMICS S210 servo drive

#### Accessories

##### Line filters

###### 1 AC series

Filters are already integrated in order to achieve category C2 (for motor cable lengths up to 10 m) or category C3 (for motor cable lengths up to 25 m). Further requirements can be achieved using an external line filter.

1 AC series	Maximum motor cable length	
	for converters without additional line filter	for converters with external line filter
EMC category C2	10 m (32.8 ft)	25 m (82.0 ft)
EMC category C3	25 m (82.0 ft)	50 m (164 ft)

###### 3 AC series

Filters for achieving category C3 are already integrated (for motor cable lengths up to 25 m). Further requirements can be achieved using an external line filter.

3 AC series	Line/DC link coupling	Maximum motor cable length	
		for converters with integrated line filter	for converters with external line filter
EMC category C2	Without line/DC link coupling	–	25 m (82 ft)
	With line/DC link coupling ≤ 6 converters <sup>1)</sup>	–	100 m (328 ft)
EMC category C3	Without line/DC link coupling	25 m (82 ft)	50 m (164 ft)
	With line/DC link coupling ≤ 6 converters <sup>1)</sup>	100 m (328 ft)	250 m (820 ft)



Example: SINAMICS S210, 3 AC line filter with servo converter, frame size FSB

##### Recommended line-side overcurrent protection devices

Overcurrent protection devices are absolutely necessary for the operation of the converters. The table listed in the section "Recommended line-side overcurrent protection devices" provides recommendations according to IEC and UL regulations, depending on the area of application. Recommendations on further overcurrent protection devices are available at: <https://support.industry.siemens.com/cs/document/109748999>

Additional information about the listed Siemens fuses is available in Catalog LV 10 as well as in the Industry Mall.

##### Braking resistors

As far as necessary, braking resistors are integrated into the converters. Together with the generously dimensioned DC link capacities, an external braking resistor is not necessary in the normal case.

If the internal braking resistor is inadequate for applications with very high requirements, an external braking resistor can be connected as an alternative. When operating a SINAMICS S210 servo converter with a supply voltage of 200 V to 240 V 3 AC, an external, intrinsically safe braking resistor is always required.

##### Memory cards

A memory card (SINAMICS SD card) can be optionally used with SINAMICS S210. The associated slot is located under the front cover of the converter. Not only the firmware but also the device parameterization of a SINAMICS S210 servo converter can be stored on the memory card.

When service is required, e.g. after the converter has been replaced and the data have been downloaded from the memory card, the drive system is immediately ready for use again.

A memory card is only absolutely necessary if functions requiring license, such as the Extended Safety Functions, are used. The necessary license is saved on the memory card.

<sup>1)</sup> The data is applicable for the complete cable length of the motors, whose associated converters are coupled with one another via an AC coupling or through the DC link.  
The maximum cable length per motor is 25 m using the internal filters or an external filter to achieve EMC category C2. If an external filter is used to achieve EMC category C3, the maximum cable length per motor is 50 m.

## Overview



1 AC line filter, 18 A



3 AC line filter, 35 A and 65 A

The line filters are connected via the AC coupling of the converters.  
The total of the rated currents of the converters on an AC bus must not exceed the rated current of the line filter.

## Selection and ordering data

Rated current of the servo converter A	Suitable for SINAMICS S210	Line filter Article No.
<b>Line voltage 200 ... 240 V 1 AC</b>		
1.4	6SL3210-5HB10-1UF0	<b>NEW</b> 6SL3203-0BB21-8VA1
2.7	6SL3210-5HB10-2UF0	
5	6SL3210-5HB10-4UF0	
9.3	6SL3210-5HB10-8UF0	
<b>Line voltage 200 ... 480 V 3 AC</b>		
1.6	6SL3210-5HE10-4UF0	
2.8	6SL3210-5HE10-8UF0	
3.8	6SL3210-5HE11-0UF0	
6	6SL3210-5HE11-5UF0	
7.5	6SL3210-5HE12-0UF0	
12.5	6SL3210-5HE13-5UF0	
15	6SL3210-5HE15-0UF0	
17.9	6SL3210-5HE17-0UF0	
	• Total of the currents $\leq 35$ A	<b>NEW</b> 6SL3203-0BE23-5HA0
	• Total of the currents $\leq 65$ A	<b>NEW</b> 6SL3203-0BE26-5HA0

## Technical specifications

<b>Line voltage</b> 200 ... 240 V 1 AC	<b>Line filter</b> 6SL3203-0BB21-8VA1	
<b>Rated current</b>	A	18
<b>Power loss</b>	W	< 1.2
<b>Line/load connection</b>	Screw terminals	
• Conductor cross-section	mm <sup>2</sup>	0.25 ... 6 AWG 24 ... 10
- For single-conductor connection	mm <sup>2</sup>	0.25 ... 4 AWG 24 ... 12
- For flexible cables		
<b>PE connection</b>	M5 screw stud	
<b>Degree of protection</b>	IP20	
<b>Dimensions</b>		
• Width	mm (in)	62 (2.44)
• Height	mm (in)	155 (6.10)
• Depth	mm (in)	53 (2.09)
<b>Weight, approx.</b>	kg (lb)	0.7 (1.54)
<b>Suitable for SINAMICS S210 servo converter</b>	Type	6SL3210-5HB10-1UF0 (1.4 A) 6SL3210-5HB10-2UF0 (2.7 A) 6SL3210-5HB10-4UF0 (5 A) 6SL3210-5HB10-8UF0 (9.3 A)
<b>Line voltage</b> 200 ... 480 V 3 AC	<b>Line filter</b> 6SL3203-0BE23-5HA0 6SL3203-0BE26-5HA0	
<b>Rated current</b>	A	35 65
<b>Power loss</b>	W	12 18
<b>Line supply connection</b>	Screw terminals Screw terminals	
• Conductor cross-section	mm <sup>2</sup>	0.5 ... 10 AWG 24 ... 6 4 ... 25 AWG 10 ... 3
<b>Load connection</b>	Screw terminals Screw terminals	
• Conductor cross-section	mm <sup>2</sup>	16 AWG 6 16 AWG 6
<b>PE connection</b>	M4 screw stud M5 screw stud	
<b>Degree of protection</b>	IP20 IP20	
<b>Dimensions</b>		
• Width	mm (in)	50 (1.97) 70 (2.76)
• Height	mm (in)	296.2 (11.66) 348.8 (13.73)
• Depth	mm (in)	220 (8.66) 220 (8.66)
<b>Weight, approx.</b>	kg (lb)	2.3 (5.07) 3.5 (7.72)
<b>Suitable for SINAMICS S210 servo converter</b>	Type	6SL3210-5HE10-4UF0 (1.6 A) 6SL3210-5HE10-8UF0 (2.8 A) 6SL3210-5HE11-0UF0 (3.8 A) 6SL3210-5HE11-5UF0 (6 A) 6SL3210-5HE12-0UF0 (7.5 A) 6SL3210-5HE13-5UF0 (12.5 A) 6SL3210-5HE15-0UF0 (15 A) 6SL3210-5HE17-0UF0 (17.9 A)

**SINAMICS S210 servo drive**

0.1 kW to 7 kW

**Line-side components > Recommended line-side overcurrent protection devices****Selection and ordering data**

Overcurrent protection devices are absolutely necessary for the operation of the converters. The following table lists recommendations for fuses.

- Siemens fuses of type 3NA3 for use in the area of validity of IEC
- UL-listed fuses Class J for use in USA and Canada

Recommendations on further overcurrent protection devices are available at:

<https://support.industry.siemens.com/cs/document/109748999>

The Short Circuit Current Rating (SCCR) according to UL for industrial control cabinet installations to NEC Article 409 or UL 508A/508C or UL 61800-5-1 is as follows for Class J fuses for

- SINAMICS S210: 65 kA

SCCR and ICC values for combination with further overcurrent protection devices are available at:

<https://support.industry.siemens.com/cs/document/109748999>

Notes for installations in Canada:

The converters are intended for line supply systems with overvoltage category III.

More information is available in the technical documentation on the Internet at:

[www.siemens.com/sinamics-s210/documentation](http://www.siemens.com/sinamics-s210/documentation)

Additional information about the listed Siemens fuses is available in Catalog LV 10 as well as in the Industry Mall.

Rated power kW	SINAMICS S210 Type	IEC-compliant Fuse		UL/cUL-compliant Fuse type Rated voltage 600 V AC	
		Current A	3NA3 Article No.	Class	Current A
<b>Line voltage 200 ... 240 V 1 AC</b>					
0.1	6SL3210-5HB10-1UF0	6	3NA3801	J	6
0.2	6SL3210-5HB10-2UF0	6	3NA3801	J	6
0.4	6SL3210-5HB10-4UF0	10	3NA3803	J	10
0.75	6SL3210-5HB10-8UF0	16	3NA3805	J	20
<b>Line voltage 200 ... 480 V 3 AC</b>					
0.4	6SL3210-5HE10-4UF0	16	3NA3805	J	15
0.75	6SL3210-5HE10-8UF0	16	3NA3805	J	15
1	6SL3210-5HE11-0UF0	16	3NA3805	J	15
1.5	6SL3210-5HE11-5UF0	32	3NA3812	J	30
2	6SL3210-5HE12-0UF0	32	3NA3812	J	30
3.5	6SL3210-5HE13-5UF0	63	3NA3822	J	70
5	6SL3210-5HE15-0UF0	63	3NA3822	J	70
7	6SL3210-5HE17-0UF0	63	3NA3822	J	70

Group protection of multiple converters

Further information is available in the technical documentation on the Internet at:

[www.siemens.com/sinamics-s210/documentation](http://www.siemens.com/sinamics-s210/documentation)

<https://support.industry.siemens.com/cs/document/109748999>

## Overview

As far as necessary, braking resistors are integrated into the converters. Together with the generously dimensioned DC link capacities, another external braking resistor is not necessary in the normal case.

If the internal braking resistor is inadequate for applications with very high requirements, an external braking resistor can be connected as an alternative.

Only intrinsically safe braking resistors with temperature monitoring may be used in order to minimize the risk of an explosion, the outbreak of fire or melting of the enclosure in the event of a continuous overload, e.g. due to a defect.

### External braking resistors for 200 V to 240 V 3 AC



For operation with a supply voltage of 200 V to 240 V 3 AC, an external, intrinsically safe braking resistor is always required for each converter. Use of braking resistors integrated in the converter is not permissible with this supply voltage.

The following resistors are recommended as a substitute for the internal braking resistors. If these are not sufficient, the resistors from Michael Koch GmbH listed in the table can be used.

- 100 W, 47  $\Omega$  for frame sizes FSA and FSB:  
**GXK:BWG250047TS-190**
- 240 W, 14  $\Omega$  for frame size FSC:  
**GXK:BWG600014TS-190**

These resistors have approvals for the North American market (cURus and CSA).

If the temperature sensor of the resistor is connected to the input DI4 of the converter, the converter switches off when the braking resistor is overloaded.

## More Information

Further information is available from the "Siemens Product Partner for Drives Options":

[www.siemens.com/drives-options-partner](http://www.siemens.com/drives-options-partner)

## Technical specifications

### Requirements placed on an external braking resistor

Converter Article No.	Rated power kW	Braking resistor			
		Min. resistance $\Omega$	Max. continuous power W	Max. peak power W	Max. braking energy kJ
<b>Line voltage 200 ... 240 V 1 AC</b>					
5HB10-1UF0	0.1	300	50	350	0.7
5HB10-2UF0	0.2	150	100	600	1.3
5HB10-4UF0	0.4	100	200	1300	2.3
5HB10-8UF0	0.75	50	380	2400	3.8
<b>Line voltage 200 ... 240 V 3 AC</b>					
5HE10-4UF0	0.4	100	200	600	1
5HE10-8UF0	0.75	100	380	1200	1
5HE11-0UF0	1	100	500	1700	1
5HE11-5UF0	1.5	50	880	2900	20
5HE12-0UF0	2	50	1000	3800	20
5HE13-5UF0	3.5	15	1750	7500	25
5HE15-0UF0	5	15	2500	9500	25
5HE17-0UF0	7	15	3250	12500	25
<b>Line voltage 380 ... 480 V 3 AC</b>					
5HE10-4UF0	0.4	200	200	1200	8
5HE10-8UF0	0.75	200	380	2400	8
5HE11-0UF0	1	200	500	3400	8
5HE11-5UF0	1.5	100	880	5700	80
5HE12-0UF0	2	100	1000	7600	80
5HE13-5UF0	3.5	30	1750	15000	100
5HE15-0UF0	5	30	2500	19000	100
5HE17-0UF0	7	30	3250	25000	100

### Examples of braking resistors from Michael Koch GmbH

Converter Article No.	Braking resistors from Michael Koch GmbH Order designation with temperature sensor 190 °C	Continuous power		Max. peak power W	Max. braking energy kJ
		for CE W	for UL W		
6SL3210-...					
<b>Line voltage 200 ... 240 V 1 AC</b>					
5HB10-1UF0	BWG250047TS-190	50	50	350	0.7
5HB10-2UF0	BWG250047TS-190	100	100	600	1.1
5HB10-4UF0	BWG250047TS-190	100	100	1300	1.8
5HB10-8UF0	BWG500027TS-190	200	200	2400	2.7
<b>Line voltage 200 ... 240 V 3 AC</b>					
5HE10-4UF0	BWG500027TS-190	200	200	600	0.9
5HE10-8UF0	BWG600014TS-190	380	240	1200	0.8
5HE11-0UF0	BWG600014TS-190	400	240	1700	0.8
5HE11-5UF0	BWD500027K03LIP65IS	600	600	2900	14.5
5HE12-0UF0	BWD500027K03LIP65IS	600	600	3800	13.9
5HE13-5UF0	BWD600014K03LIP65IS	1200	720	7500	18.7
5HE15-0UF0	BWD600014K03LIP65IS	1200	720	9500	17.8
5HE17-0UF0	BWD600014K03LIP65IS	1200	720	12500	18.2
<b>Line voltage 380 ... 480 V 3 AC</b>					
5HE10-4UF0	BWG500100TS-190	200	200	1200	5.2
5HE10-8UF0	BWG600047TS-190	380	240	2400	6.2
5HE11-0UF0	BWG600047TS-190	400	240	3400	6.1
5HE11-5UF0	BWD500100K03LIP65IS	600	600	5700	30.4
5HE12-0UF0	BWD500100K03LIP65IS	600	600	7600	30.4
5HE13-5UF0	BWD600047K03LIP65IS	1200	720	15000	50
5HE15-0UF0	BWD600047K03LIP65IS	1200	720	19000	47.5
5HE17-0UF0	BWD600047K03LIP65IS	1200	720	25000	41.7

**SINAMICS S210 servo drive**

0.1 kW to 7 kW

Supplementary system components &gt; Memory cards

**Overview**

SINAMICS memory card (SD card)

The parameter assignment, firmware and licenses for a converter can be stored on the SINAMICS memory card (SD card). When service is required, e.g. after the converter has been replaced and the data have been downloaded from the memory card the drive system is immediately ready for use again.

The memory card has the following functions:

- Parameter settings can be written from the memory card to the converter or saved from the converter to the memory card
- The memory card supports series commissioning without the use of a commissioning tool
- If firmware is stored on the memory card, the firmware can be upgraded/downgraded during startup
- It is used for storing licenses when using functions under license, e.g. the license for enabling the Extended Safety Functions
  - Safe Stop 2 (SS2)
  - Safe Operating Stop (SOS)
  - Safely-Limited Speed (SLS)
  - Safe Speed Monitor (SSM)
  - Safe Direction (SDI)
  - Safely-Limited Acceleration (SLA)
  - Safe Brake Test (SBT) diagnostic function

Notes:

In general, the converter can be operated without a memory card. However, it is necessary if licenses, such as the Extended Safety license, are required. The card must then remain permanently inserted.

Firmware V5.2 or higher is required for the 3 AC series or when using the SINAMICS Startdrive commissioning tool.

**Selection and ordering data**

Description	Article No.
<b>SINAMICS SD card</b> 512 MB Firmware V5.2 or higher is required for the 3 AC series.	
• Empty	<b>6SL3054-4AG00-2AA0</b>
• With firmware V5.1	<b>6SL3054-4FB00-2BA0</b>
• With firmware V5.1 SP1	<b>6SL3054-4FB10-2BA0</b>
• With firmware V5.1 SP1 and Safety license (Extended Functions)	<b>6SL3054-4FB10-2BA0-Z F01</b>
• With firmware V5.2	<b>6SL3054-4FC00-2BA0</b>
• With firmware V5.2 and Safety license (Extended Functions)	<b>6SL3054-4FC00-2BA0-Z F01</b>
• With firmware V5.2 SP3	<b>NEW 6SL3054-4FC30-2BA0</b>
• With firmware V5.2 SP3 and Safety license (Extended Functions)	<b>NEW 6SL3054-4FC30-2BA0-Z F01</b>
<b>Safety license</b> (Extended Functions) <sup>1)</sup>	
• CoL in paper form	<b>6SL3074-0AA10-0AA0</b>
• CoL in electronic form	<b>NEW 6SL3074-0AA10-0AH0</b>

<sup>1)</sup> Extended function for an existing memory card (firmware V5.1 SP1 or higher). The memory card is not included in the scope of delivery. The Safety license can also be ordered together with a memory card (see above). With a CoL in electronic form, the license is supplied as a PDF file. Notification of this with a download link is received by email. [For further information to CoL in electronic form, see next page.](#)  
[For further information to CoL, see section Software licenses.](#)

**More information**

**Certificate of License (CoL)**

The CoL is the licensee's proof that the use of the software has been licensed by Siemens. A CoL must be assigned to each use and must be kept in a safe place.

**Electronic Certificate of License**

The electronic Certificate of License is the paperless delivery form for runtime options for SINAMICS, SIMOTION, and SINUMERIK.

Like the previous paper Certificate of License CoL, the electronic Certificate of License contains information about the type of rights of use purchased for the software. The electronic Certificate of License is supplied as a PDF file via the Online Software Delivery Portal (OSD). This enables quick notification with a download link to the email address to be stated in the order.

The electronic Certificate of License can then be downloaded from the OSD. The Web License Manager can also be called from the OSD to assign the runtime license to a memory card. In this case, the data of the electronic Certificate of License are automatically transferred to the Web License Manager and do not have to be entered manually. This ensures quick availability of the license key and simple and secure handling and management of the license certificates.

You will find information on the OSD at:  
<https://support.industry.siemens.com/cs/ww/en/view/109759444>

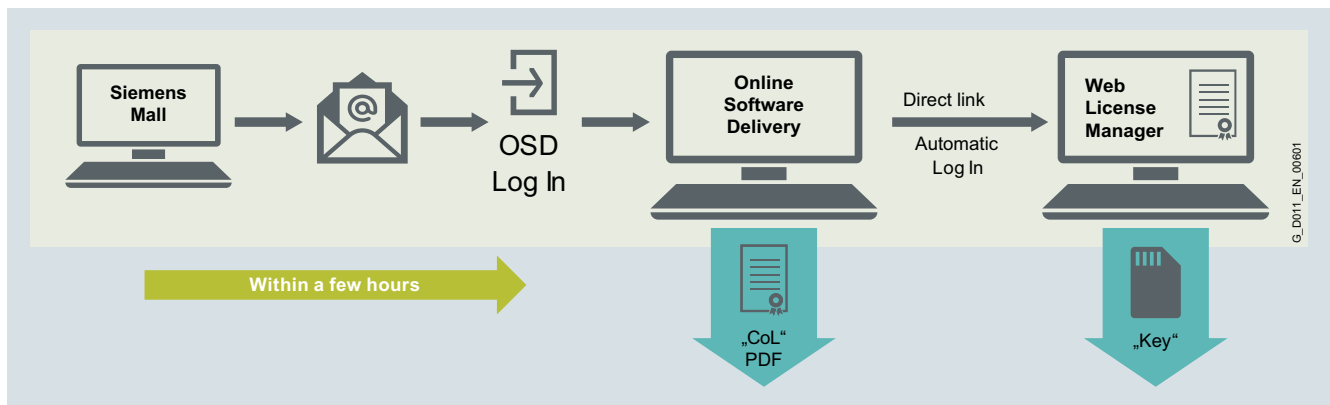

Electronic Certificate of License: Procedure for order licenses

In the future, the pre-licensed memory cards will also be delivered with the corresponding electronic Certificates of License on the memory card. The Certificates of License are stored in directory "KEYS". The pre-licensed memory cards will successively make the transition from paper CoLs to electronic CoLs. The CoL on paper will then no longer be contained in the delivery.

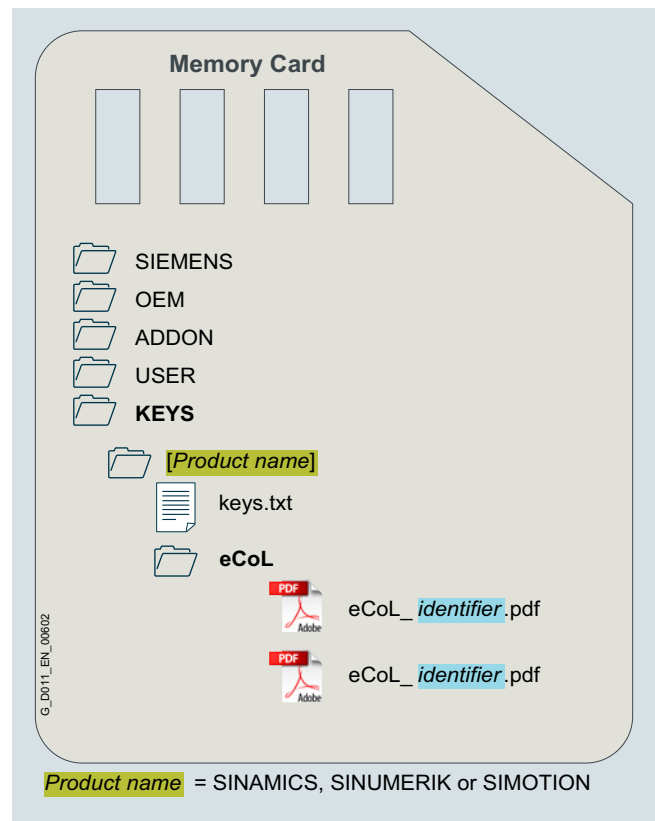

Electronic Certificate of License: Storage location on data medium

## SINAMICS S210 servo drive

### Notes

2

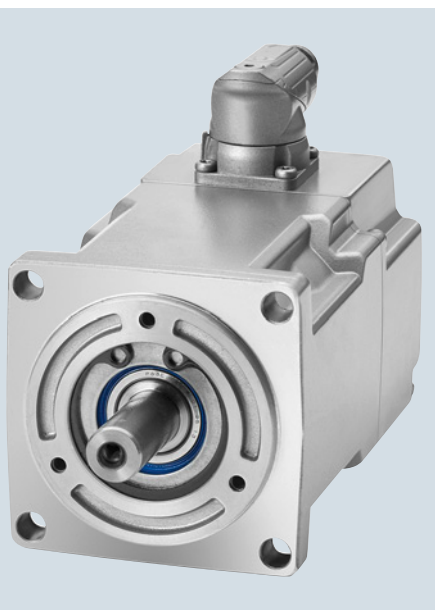

**SIMOTICS S-1FK2 servomotors****3/2****SIMOTICS S-1FK2 servomotors for SINAMICS S210**

3/2 Overview

3/2 Benefits

3/2 Application

3/3 Selection and ordering data

3/6 Technical specifications

3/6 General technical specifications

3/11 SIMOTICS S-1FK2 shaft height 20

3/13 SIMOTICS S-1FK2 shaft height 30

3/15 SIMOTICS S-1FK2 shaft height 40

3/19 SIMOTICS S-1FK2 shaft height 48

3/21 SIMOTICS S-1FK2 shaft height 52

3/23 SIMOTICS S-1FK2 shaft height 63

3/26 SIMOTICS S-1FK2 shaft height 80

3/29 SIMOTICS S-1FK2 shaft height 100

Detailed technical information on the SINAMICS S210 servo drive system is available on the Internet at:

[www.siemens.com/sinamics-s210/documentation](http://www.siemens.com/sinamics-s210/documentation)

In addition, the Drive Technology Configurator (DT Configurator) can be used on the Internet at the following address:

[www.siemens.com/dt-configurator](http://www.siemens.com/dt-configurator)

## SIMOTICS S-1FK2 servomotors

### SIMOTICS S-1FK2 servomotors for SINAMICS S210

#### Overview

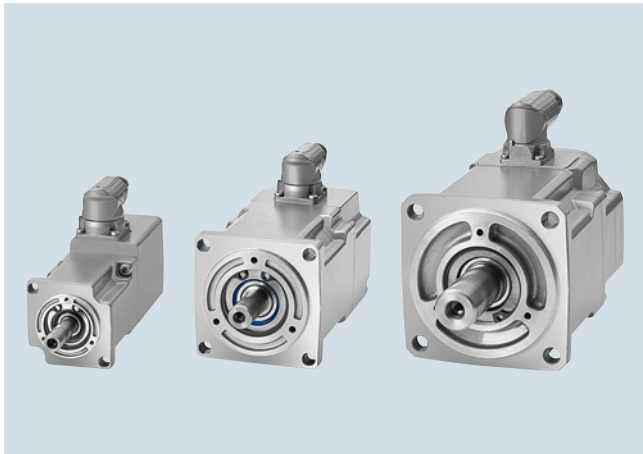

The SIMOTICS S-1FK2 servomotors are compact and highly dynamic synchronous motors for a wide range of uses in an industrial environment. They are characterized by high power density, degree of protection and overload capability.

#### **SIMOTICS S-1FK2 High Dynamic motors**

Highest dynamic response through low inertia for highly dynamic applications with low moved masses.

#### **SIMOTICS S-1FK2 Compact motors**

Precise, stable control with medium to high masses to be moved with medium moment of inertia.

#### Benefits

The SIMOTICS S-1FK2 servomotors fully exploit their strengths in the system with the SINAMICS S210 converter:

- Short adjustment and positioning times
- Quick and precise compensation of disturbances
- Stable closed loop control with high dynamic response





This is achieved by:

- Rapid control cycle
- High pulse frequency
- Complex rule algorithms
- High-resolution optical encoder with fast scanning
- Low moment of inertia of the motors
- High overload capability

#### Application

- Packaging machines
- Handling equipment
- Feed and withdrawal devices
- Stacking units
- Automatic assembly machines
- Laboratory automation
- Woodworking, glass and ceramic industries
- Digital printing machines







## Selection and ordering data

	Static torque	Maximum torque	Maximum speed	Rated speed for 200 ... 240 V 1 AC / 3 AC	Rated speed for 380 ... 480 V 3 AC	Rotor moment of inertia	SIMOTICS S-1FK2 servomotor
	$M_0$ Nm (lb <sub>r</sub> -ft)	$M_{max}$ Nm (lb <sub>r</sub> -ft)	$n_{max}$ rpm	$n_{rated}$ rpm	$n_{rated}$ rpm	$J_{Mot}$ kg cm <sup>2</sup> (lb <sub>r</sub> -in <sup>2</sup> )	
<b>High Dynamic for highly dynamic applications</b>							
<b>Shaft height 20</b>							
	0.16 (0.12)	0.56 (0.41)	8000	3000	–	0.025 (0.009)	<b>1FK2102-0AG</b> ■■■-■■■A0
	0.32 (0.24)	1.11 (0.82)	8000	3000	–	0.036 (0.012)	<b>1FK2102-1AG</b> ■■■-■■■A0
<b>Shaft height 30</b>							
	0.64 (0.47)	1.95 (1.44)	8000	3000	–	0.093 (0.032)	<b>1FK2103-2AG</b> ■■■-■■■A0
	1.27 (0.94)	4.05 (2.99)	8000	3000	–	0.14 (0.048)	<b>1FK2103-4AG</b> ■■■-■■■A0
<b>Shaft height 40</b>							
	1.27 (0.94)	3.75 (2.77)	7200	1500	3000	0.35 (0.120)	<b>1FK2104-4AF</b> ■■■-■■■A0
	1.27 (0.94)	3.85 (2.84)	8000	3000	–	0.35 (0.120)	<b>1FK2104-4AK</b> ■■■-■■■A0
	2.4 (1.77)	7.5 (5.53)	6700	1500	3000	0.56 (0.191)	<b>1FK2104-5AF</b> ■■■-■■■A0
	2.4 (1.77)	7.6 (5.61)	8000	3000	–	0.56 (0.191)	<b>1FK2104-5AK</b> ■■■-■■■A0
	3.2 (2.36)	10 (7.38)	7200	1500	3000	0.76 (0.260)	<b>1FK2104-6AF</b> ■■■-■■■A0
<b>Shaft height 52</b>							
	5 (3.69)	15 (11.06)	6000	1500	3000	1.7 (0.581)	<b>NEW</b> <b>1FK2105-4AF</b> ■■■-■■■A0
	8 (5.90)	24 (17.70)	6000	1500	3000	2.7 (0.923)	<b>NEW</b> <b>1FK2105-6AF</b> ■■■-■■■A0
<b>Shaft height 63</b>							
	9 (6.64)	24.5 (18.07)	6000	1500	3000	4.6 (1.572)	<b>NEW</b> <b>1FK2106-3AF</b> ■■■-■■■A0
	12 (8.85)	32.5 (23.97)	6000	1500	3000	6.0 (2.050)	<b>NEW</b> <b>1FK2106-4AF</b> ■■■-■■■A0
	16 (11.80)	42 (30.98)	6000	1500	3000	8.7 (2.973)	<b>NEW</b> <b>1FK2106-6AF</b> ■■■-■■■A0
<b>Article No. supplements</b>							
<b>Holding brake</b>							
Without brake							0
With brake							1
<b>Degree of protection</b>							
IP64 (without shaft sealing ring)							0
IP65 (with shaft sealing ring)							1
<b>Shaft extension, feather key</b>							
Plain shaft							0
Shaft with feather key							1
Plain shaft, reduced shaft diameter, Ø11 × 23 mm (0.43 × 0.91 in) (only for 1FK2.03 and IP64), Ø14 × 30 mm (0.55 × 1.18 in) (only for 1FK2.04 and IP64)							0 2
<b>Encoder</b>							
Absolute encoder 22-bit singleturn							S
Absolute encoder 22-bit + 12-bit multiturn							M

## SIMOTICS S-1FK2 servomotors

## SIMOTICS S-1FK2 servomotors for SINAMICS S210

## Selection and ordering data

	Static torque	Maximum torque	Maximum speed	Rated speed for 200 ... 240 V 1 AC / 3 AC		Rated speed for 380 ... 480 V 3 AC	Rotor moment of inertia	SIMOTICS S-1FK2 servomotor
	$M_0$ Nm (lb <sub>r</sub> -ft)	$M_{max}$ Nm (lb <sub>r</sub> -ft)	$n_{max}$ rpm	$n_{rated}$ rpm	$n_{rated}$ rpm	$n_{rated}$ rpm	$J_{Mot}$ kg cm <sup>2</sup> (lb <sub>r</sub> -in <sup>2</sup> )	
<b>Compact for high precision applications</b>								
<b>Shaft height 30</b>								
	0.64 (0.47)	1.85 (1.36)	8000	3000	–	–	0.20 (0.068)	<b>1FK2203-2AG</b> ■■■ ■■■ A0
	1.27 (0.94)	3.75 (2.77)	8000	3000	–	–	0.35 (0.120)	<b>1FK2203-4AG</b> ■■■ ■■■ A0
<b>Shaft height 40</b>								
	2.4 (1.77)	7.1 (5.24)	7500	1500	3000	–	1.2 (0.410)	<b>1FK2204-5AF</b> ■■■ ■■■ A0
	2.4 (1.77)	7.1 (5.24)	8000	3000	6000	–	1.2 (0.410)	<b>1FK2204-5AK</b> ■■■ ■■■ A0
	3.2 (2.36)	9.5 (7.01)	7600	1500	3000	–	1.6 (0.547)	<b>1FK2204-6AF</b> ■■■ ■■■ A0
<b>Shaft height 48</b>								
	3.6 (2.66)	10.8 (7.97)	6000	1500	3000	–	3.2 (1.093)	<b>NEW</b> <b>1FK2205-2AF</b> ■■■ ■■■ A0
	6 (4.43)	18 (13.28)	6000	1500	3000	–	5.1 (1.743)	<b>NEW</b> <b>1FK2205-4AF</b> ■■■ ■■■ A0
<b>Shaft height 63</b>								
	6.5 (4.79)	18 (13.28)	6000	1500	3000	–	7.8 (2.665)	<b>NEW</b> <b>1FK2206-2AF</b> ■■■ ■■■ A0
	12 (8.85)	36 (26.55)	5800	1500	3000	–	15 (5.126)	<b>NEW</b> <b>1FK2206-4AF</b> ■■■ ■■■ A0
<b>Shaft height 80</b>								
	18 (13.28)	51 (37.62)	4100	1000	2000	–	30 (10.251)	<b>NEW</b> <b>1FK2208-3AC</b> ■■■ ■■■ A0
	22 (16.23)	66 (48.68)	4600	1000	2000	–	39 (13.326)	<b>NEW</b> <b>1FK2208-4AC</b> ■■■ ■■■ A0
	27 (19.92)	80 (59.01)	4700	1000	2000	–	48 (16.402)	<b>NEW</b> <b>1FK2208-5AC</b> ■■■ ■■■ A0
<b>Shaft height 100</b>								
	30 (22.13)	90 (66.38)	2500	750	1500	–	89 (30.411)	<b>NEW</b> <b>1FK2210-3AB</b> ■■■ ■■■ A0
	30 (22.13)	90 (66.38)	4400	1000	2000	–	89 (30.411)	<b>NEW</b> <b>1FK2210-3AC</b> ■■■ ■■■ A0
	40 (29.50)	120 (88.51)	2500	750	1500	–	120 (41.004)	<b>NEW</b> <b>1FK2210-4AB</b> ■■■ ■■■ A0
	40 (29.50)	120 (88.51)	3300	1000	2000	–	120 (41.004)	<b>NEW</b> <b>1FK2210-4AC</b> ■■■ ■■■ A0

## Article No. supplements

## Holding brake

Without brake

0

With brake

1

## Degree of protection

IP64 (without shaft sealing ring)

0

IP65 (with shaft sealing ring)

1

## Shaft extension, feather key

Plain shaft

0

Shaft with feather key

1

Plain shaft, reduced shaft diameter, Ø11 × 23 mm (0.43 × 0.91 in) (only for 1FK2.03 and IP64), Ø14 × 30 mm (0.55 × 1.18 in) (only for 1FK2.04 and IP64)

0

2

## Encoder

Absolute encoder 22-bit singleturn

S

Absolute encoder 22-bit + 12-bit multiturn

M

## Selection and ordering data

## Accessories

Description	For motor	Article No.
<b>Shaft sealing ring</b>	1FK2.02	<b>1FK2902-0GC00</b>
To achieve degree of protection IP65	1FK2.03	<b>1FK2903-0GC00</b>
Degree of protection kit for mounting on the motor for retrofitting or as spare part	1FK2.04	<b>1FK2904-0GC00</b>

## Structure of the Article No. of the SIMOTICS S-1FK2 servomotors

Data position in Article No.	1	2	3	4	5	6	7	8	9	10	11	12	13	14	15	16		
	<b>1</b>	<b>F</b>	<b>K</b>	<b>2</b>	■	■	■	-	■	<b>A</b>	■	■	■	-	■	■	<b>A</b>	<b>0</b>
<b>1st to 4th position:</b> digit, letter, letter, digit	<b>Motor</b> 1 F K 2																	
<b>5th position:</b> digit	<b>Moment of inertia</b>																	
	High Dynamic				1													
	Compact				2													
<b>6th and 7th positions:</b> digit, digit	<b>Shaft height</b>																	
	20					0	2											
	30					0	3											
	40					0	4											
	52				1	0	5											
	48				2	0	5											
	63					0	6											
	80					0	8											
	100					1	0											
<b>8th position:</b> digit	<b>Overall length</b>				See specific technical specifications				0 ... 8									
<b>9th position:</b> letter	Reserved								A									
<b>10th position:</b> letter	<b>Winding/rated speed</b>																	
	<b>For converters connected to max. 240 V</b>				<b>For converters connected to max. 480 V</b>													
	750 rpm at 230 V				1500 rpm at 400 V				B									
	1000 rpm at 240 V				2000 rpm at 400 V				C									
	1500 rpm at 230 V				3000 rpm at 400 V				F									
	3000 rpm at 230 V				Not permissible				G									
	3000 rpm at 230 V				6000 rpm at 400 V				K									
<b>11th position:</b> digit	<b>Brake</b>																	
	None								0									
	Holding brake								1									
<b>12th position:</b> digit	<b>Degree of protection</b>																	
	IP64 (without shaft sealing ring)								0									
	IP65 (with shaft sealing ring)								1									
<b>13th position:</b> digit	<b>Shaft extension, feather key</b>																	
	Plain shaft												0					
	Shaft with feather key												1					
	Plain shaft, reduced shaft diameter Ø11 × 23 mm (0.43 × 0.91 in) (only for 1FK2.03 and IP64), Ø14 × 30 mm (0.55 × 1.18 in) (only for 1FK2.04 and IP64)												0	2				
<b>14th position:</b> letter	<b>Encoder</b>																	
	Absolute encoder 22-bit singleturn (AS22DQC)														S			
	Absolute encoder 22-bit + 12-bit multiturn (AM22DQC)														M			
<b>15th position:</b> letter	<b>One Cable Connection</b>															A		
<b>16th position:</b> digit	Reserved																0	

# SIMOTICS S-1FK2 servomotors

## SIMOTICS S-1FK2 servomotors for SINAMICS S210

### Technical specifications

#### General technical specifications

SIMOTICS S-1FK2 High Dynamic/Compact motors	
<b>Motor type</b>	Permanent-magnet synchronous motor
<b>Permissible operating conditions without derating</b> • Ambient temperature • Installation altitude, max.	-15 ... +40 °C (5 ... 104 °F) 1000 m (3281 ft)
<b>Degree of protection</b> According to EN 60034-5 (IEC 60034-5)	IP64 IP65 optional or retrofittable
<b>Cooling</b> According to EN 60034-6	Natural cooling (IC410)
<b>Type of construction</b> According to EN 60034-7 (IEC 60034-7)	IM B5 (IM V1, IM V3)
<b>Shaft extension</b> According to DIN 748-3 (IEC 60072-1)	Plain shaft Optional shaft with feather key (half-key balancing)
<b>Shaft and flange accuracy</b> According to DIN 42955 (IEC 60072-1)	Tolerance N In each case for radial eccentricity of the shaft extension, concentricity of the centering ring, and axial eccentricity of the mounting flange to the axis of the shaft extension.
<b>Vibration severity grade</b> According to EN 60034-14 (IEC 60034-14)	Grade A is maintained up to rated speed
<b>Stator winding insulation</b> According to EN 60034-1 (IEC 60034-1) • 1FK2102, 1FK2.03  • 1FK2.04, 1FK2.05, 1FK2.06, 1FK2.08, 1FK2.10	Thermal class 130 (B) for a winding overtemperature of $\Delta T = 80$ K Thermal class 155 (F) for a winding overtemperature of $\Delta T = 100$ K
<b>Sound pressure level <math>L_{pA}</math> (1 m), max.</b> According to ISO 1680 • 1FK2102, 1FK2.03, 1FK2.04 • 1FK2.05 and 1FK2.06 • 1FK2.08 and 1FK2.10	55 dB +3 dB tolerance 65 dB +3 dB tolerance 70 dB +3 dB tolerance
<b>Encoder system</b>	• AS22DQC (absolute encoder 22-bit singleturn) • AM22DQC (absolute encoder 22-bit + 12-bit multiturn)
<b>Holding brake</b>	Optional integrated holding brake
<b>Connection</b>	One Cable Connection (OCC) for signals and power Rotatable connector
<b>Paint finish</b>	RAL 7016 (anthracite gray)
<b>Certificates of suitability</b>	cURus, CE

## Technical specifications

### Regulations, standards, specifications

The motors comply with the appropriate standards and regulations, see table below.

As a result of the fact that in many countries the national regulations have been completely harmonized with the international IEC 60034-1 recommendation, there are no longer any differences with respect to coolant temperatures, temperature classes and temperature rise limits.

General specifications for rotating electrical machines	IEC 60034-1
Terminal designations and direction of rotation for electrical machines	IEC 60034-8
Types of construction of rotating electrical machines	IEC 60034-7
Cooling methods of rotating electrical machines	IEC 60034-6
Degrees of protection of rotating electrical machines	IEC 60034-5
Vibration severity of rotating electrical machines	IEC 60034-14
Noise limit values for rotating electrical machines	IEC 60034-9
Cylindrical shaft extensions for electrical machines	DIN 748-3/IEC 60072-1



SIMOTICS S-1FK2 motors have UL approval from Underwriters Laboratories Inc. and are marked with the "UL Recognized Component" test symbol. This is used for components which are part of a larger product or system. This confirmed compliance with the corresponding US American and Canadian regulations, and allowed access to the North American market.



For SIMOTICS S-1FK2 motors, conformity with the relevant EC directives 2006/95/EC and 2014/35/EU and the relevant standards EN 60034-1:2010 and EN 60204-1:2006 is confirmed. By applying the CE mark to the product, Siemens AG confirms this for the product, and secures the free movement of goods within the European Union.

### Degree of protection acc. to IEC 60034-5

A suitable degree of protection must be selected according to the operating and environmental conditions to protect the machine against damage caused by the ingress of water and other liquids, as well as dust and foreign bodies.

SIMOTICS S-1FK2 motors have degree of protection IP64 as standard.

The motor can be optionally supplied with a radial shaft seal ring in degree of protection IP65. This increases the protection against the ingress of liquids.

The degree of protection designation is composed from the code **IP** (for International Protection) and two code numbers for the protection against touching and penetration of foreign bodies, and the degree of protection against the ingress of water.

#### First code number

6: Protection against dust ingress and complete protection against touching

#### Second code number

4: Protection against splashwater from any direction

5: Protection against jet water from any direction

#### Recommended degrees of protection for AC motors

When cooling lubricants are used, protection against water alone is inadequate. The IP rating should only be considered as a guide value in this case. The motors may have to be protected by suitable covers. Attention must be paid to providing suitable sealing of the motor shaft for the selected degree of protection for the motor.

The following table can serve as a decision aid for selecting the proper degree of protection for motors. A permanent covering of liquid on the flange must be avoided when the motor is mounted with the shaft extension facing upwards (IM V3).

Effect	General workshop environment	Water/general cooling lubricant (95 % water, 5 % oil)
Dry	IP64	–
Water-enriched environment	–	IP64
Mist	–	IP65
Spray	–	IP65

# SIMOTICS S-1FK2 servomotors

## SIMOTICS S-1FK2 servomotors for SINAMICS S210

### Technical specifications

#### Type of construction, mounting position according to IEC 60034-7

SIMOTICS S-1FK2 motors are designed in type of construction IM B5. It can also be used in mounting positions IM V1 and IM V3.

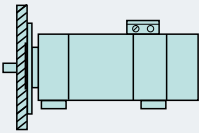
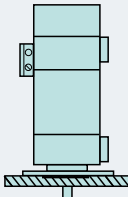
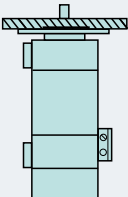
Code 1	IM B5	IM V1	IM V3
Code 2	IM 3001	IM 3011	IM 3031
			
	Horizontal flange mounting	Flange mounting, output shaft pointing vertically downwards	Flange mounting, output shaft pointing vertically upwards

#### Shaft and flange accuracy in accordance with IEC 60072-1

##### Radial eccentricity tolerance of shaft in relation to housing axis

(referred to cylindrical shaft extensions)

Motor	Shaft extensions D × L	Radial eccentricity Tolerance N
	mm (in)	
1FK2.02	8 × 25 (0.31 × 0.98)	30
1FK2.03	14 × 30 (0.55 × 1.18)	35
	11 × 23 (0.43 × 0.91)	
1FK2.04	19 × 40 (0.75 × 1.57)	40
1FK2.05	19 × 40 (0.75 × 1.57)	
1FK2.06	24 × 50 (0.94 × 1.97)	
1FK2.08	32 × 58 (1.26 × 2.28)	50
1FK2.10	38 × 80 (1.50 × 3.15)	

##### Concentricity and axial eccentricity tolerance of the flange surface for the shaft axis

(referred to the centering diameter of the mounting flange)

Motor	Centering diameter	Concentricity and axial eccentricity Tolerance N
	mm (in)	
1FK2.02	30 (1.18)	80
1FK2.03	50 (1.97)	
1FK2.04	70 (2.76)	
1FK2205	80 (3.15)	
1FK2105	95 (3.74)	100
1FK2.06	110 (4.33)	
1FK2.08	130 (5.12)	
1FK2.10	130 (5.12)	

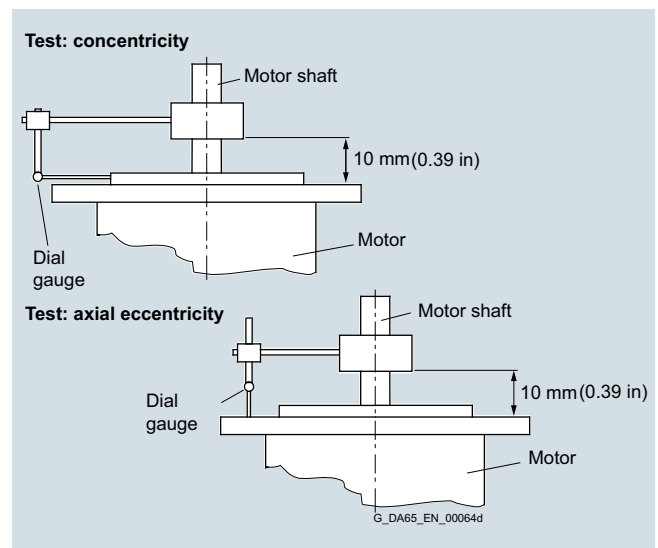
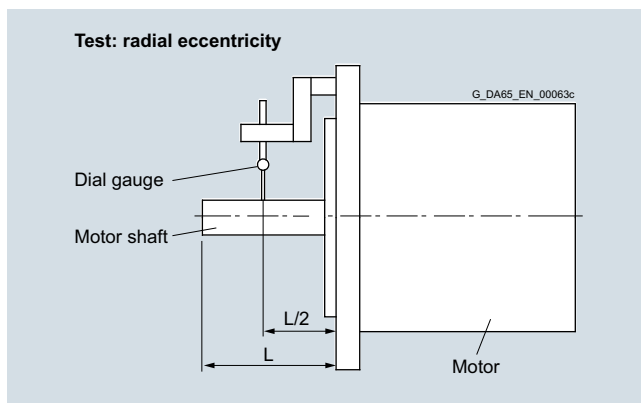



## Technical specifications

### Vibration severity and vibration severity grade A according to IEC 60034-14

The vibration severity is the RMS value of the vibration velocity (frequency range from 10 Hz to 1000 Hz). The vibration severity is measured using electrical measuring devices according to DIN 45666.

The specified values refer only to the motor. These values can increase as a result of the overall system vibrational behavior due to installation.

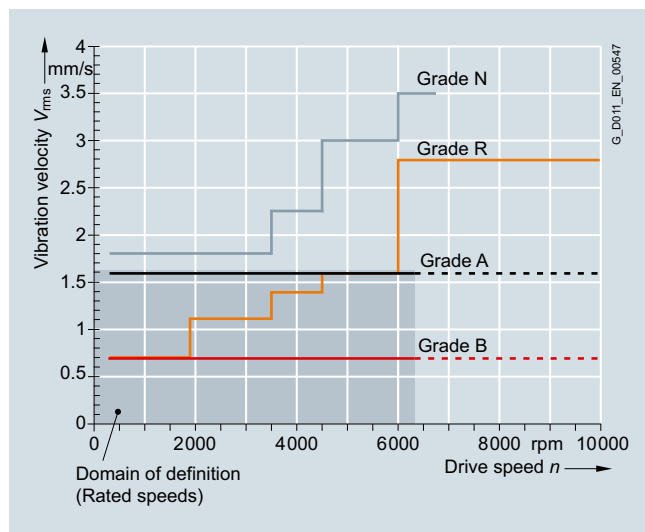

Vibration severity limit values

The speeds of 1800 rpm and 3600 rpm and the associated limit values are specified according to IEC 60034-14. The speeds of 4500 rpm and 6000 rpm and the specified values are defined by the motor manufacturer.

The motors maintain vibration severity grade A up to the rated speed.

### Balancing according to ISO 21940-32

Apart from the balance quality of the motor, the vibrational quality of motors with attached pulleys is mainly determined by the balance state of the mounted component. If the motor and the mounted component are balanced separately before being joined, the balancing process of the pulley is to be adapted to the motor's balancing type.

SIMOTICS S-1FK2 motors with feather keys are always half-key balanced. In general, motors with a plain shaft are recommended for systems with the most stringent vibrational quality requirements.

### Vibration stress, immitted vibration values

The requirements of environmental class 3M8 (according to EN 60721-3-3 Table 6) must be maintained for proper function and safeguard the bearing life. The following limits are valid for (immitted) vibration values introduced into the motor from outside:

- Vibration velocity  $V_{rms}$  according to ISO 10816, max. 4.5 mm/s
- Vibration acceleration  $a_{peak}$  axial and radial 50 m/s<sup>2</sup>

During transport, the motors withstand single shocks (6 ms) of up to 250 m/s<sup>2</sup>.

### Ambient temperature and installation altitude

Operating range without restrictions:

Temperature range from -15 °C to +40 °C, installation altitude up to 1000 m.

If deviating conditions are encountered, the S1 characteristic of the motor must be adapted with regard to speed and torque. The permitted S1 torque is calculated from  $x_D \times S1$  torque at speed  $n$ , with the derating factor  $x_D$  being taken from the table below. Intermediate values must be interpolated.

Installation altitude above sea level	Derating factor $x_D$ at an ambient temperature of			
	30 °C (86 °F)	40 °C (104 °F)	45 °C (113 °F)	50 °C (122 °F)
1000 (3281)	1.08	1	0.96	0.91
2000 (6562)	1.02	0.93	0.89	0.84

### Encoder systems

In motors with integrated OCC/DRIVE-CLiQ interface, the sensor signal is already digitally prepared in the motor, and then transferred quickly and without loss to the drive system. Motors with an OCC/DRIVE-CLiQ interface simplify commissioning and diagnostics, as the motor parameters and encoder system are identified automatically.

#### Single-turn absolute encoder

This encoder outputs an absolute angular position between 0° and 360° in the specified resolution. In contrast to the multi-turn absolute encoder, it does not have a revolution counter, and can therefore only supply the position value within one revolution. It does not have a traversing range.

#### Multi-turn absolute encoder

This encoder outputs an absolute angular position between 0° and 360° in the specified resolution. It can also count 4096 revolutions. So with a ball screw, for example, the absolute position of the slide can be determined over a longer distance.

14th position in the Article No. of the motor	Designation	
1FK2...-...-S..	AS22DQC	Absolute encoder 22-bit singleturn (resolution 4194304)
1FK2...-...-M..	AM22DQC	Absolute encoder 22-bit + 12-bit multiturn (resolution 4194304, traversing range 4096 revolutions)

## SIMOTICS S-1FK2 servomotors

### SIMOTICS S-1FK2 servomotors for SINAMICS S210

#### Technical specifications

##### Holding brake

Many drives need a holding brake with an EMERGENCY STOP function for safety reasons or to meet process requirements. The brakes used on the SIMOTICS S-1FK2 motors function according to the closed-circuit principle. A spring or permanent magnet exerts a tensile force on the brake armature disk, i.e. in a state of zero current, the brake is closed and the motor shaft thereby stopped.

An electric current that flows through a coil generates an opposing field that counteracts the force effect of the spring or permanent magnet and releases or holds open the brake. Only a limited number of braking operations can be performed for an EMERGENCY STOP or power failure without causing excessive wear on the holding brake. The holding brake is not an operational brake. Regular dynamic braking leads to increased wear and premature brake failure. In order to ensure the functionality

and specification of the brake, neither the total operating energy nor the maximum switching energy per braking operation may be exceeded.

The braking signal is already fully integrated into the SINAMICS S210 converter system, so that an external circuit is not necessary.

After an EMERGENCY STOP sequence with the maximum single switching energy, a cooling time of at least 5 minutes must be allowed.

The following table shows the technical specifications of the holding brakes for operation with SINAMICS S210 (for 1 AC devices, hardware version 2 or higher) and firmware V5.2 or higher.

Motor	Shaft height	Holding torque Nm (lb <sub>f</sub> -ft)	Dynamic braking torque Nm (lb <sub>f</sub> -ft)	Opening time ms	Closing time ms	Maximum permissible single switching energy J	Total operating energy (service life) kJ	Holding current A	Break-induced current, typ. <sup>1)</sup> for 500 ms A
1FK2.02	20	0.32 (0.24)	0.32 (0.24)	25	8	7.4	1.75	0.1	0.6
1FK2.03	30	1.3 (0.96)	1.3 (0.96)	40	10	62	17.5	0.15	0.8
1FK2.04	40	3.3 (2.43)	3.3 (2.43)	50	15	270	120	0.2	1.2
1FK2.05	50	8 (5.90)	5 (3.69)	35	15	570	284	0.3	1.1
1FK2.06	63	13 (9.59)	6.5 (4.79)	70	30	1550	774	0.35	1.1
1FK2.08-3	80	19 (14.0)	12 (8.85)	70	20	2000	1800	0.4	1.2
1FK2.08-4	80	32 (23.60)	17 (12.54)	120	35	4800	2400	0.5	1.4
1FK2208-5	80	32 (23.60)	17 (12.54)	120	35	4800	2400	0.5	1.4
1FK2210-3	100	32 (23.60)	17 (12.54)	120	35	6500	2400	0.5	1.4
1FK2210-4	100	55 (40.57)	26 (19.18)	130	35	8700	3800	0.5	1.5
1FK2210-5	100	55 (40.57)	26 (19.18)	130	35	8700	3800	0.5	1.5

<sup>1)</sup> Typical values at an ambient temperature of 20 °C.  
At -15 °C, the break-induced currents can increase by up to 30 %.

## Technical specifications

### SIMOTICS S-1FK2 shaft height 20

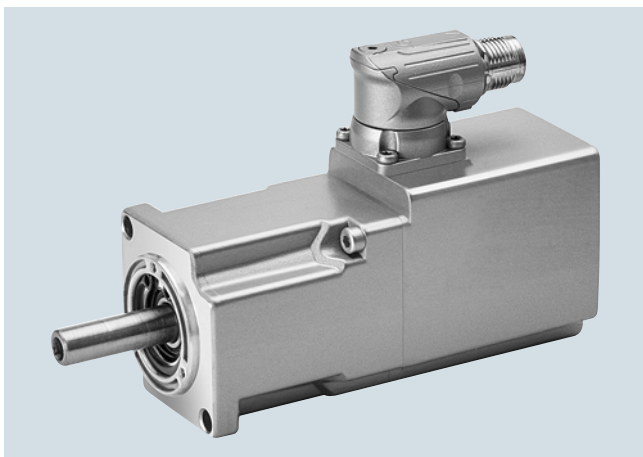

#### Specific technical specifications

SIMOTICS S-1FK2 servomotors		High Dynamic	
Shaft height 20		1FK2102-0AG	1FK2102-1AG
Static torque $M_0$	Nm (lb <sub>r</sub> -ft)	0.16 (0.12)	0.32 (0.24)
Stall current $I_0$	A	0.75	0.76
Maximum torque $M_{max}$	Nm (lb <sub>r</sub> -ft)	0.56 (0.41)	1.11 (0.82)
Maximum current $I_{max}$	A	3.1	2.95
Maximum speed $n_{max}$	rpm	8000	8000
Rotor moment of inertia $J_{Mot}$	kg cm <sup>2</sup> (lb <sub>r</sub> -in <sup>2</sup> )	0.025 (0.009)	0.036 (0.012)
Moment of inertia (with brake) $J_{Mot Br}$	kg cm <sup>2</sup> (lb <sub>r</sub> -in <sup>2</sup> )	0.029 (0.010)	0.040 (0.014)
Weight $m_{Mot}$	kg (lb)	0.47 (1.04)	0.60 (1.32)
Weight (with brake) $m_{Mot Br}$	kg (lb)	0.73 (1.61)	0.86 (1.90)
<b>200 ... 240 V 1 AC / 3 AC</b>			
Rated speed $n_{rated}$	rpm	3000	3000
Rated torque $M_{rated}$	Nm (lb <sub>r</sub> -ft)	0.16 (0.12)	0.32 (0.24)
Rated current $I_{rated}$	A	0.75	0.76
Rated power $P_{rated}$	W	50	100
Suitable for SINAMICS S210 servo converter			
• 200 ... 240 V 1 AC		6SL3210-5HB10-1UF0	6SL3210-5HB10-1UF0
• 200 ... 240 V 3 AC		6SL3210-5HE10-4UF0	6SL3210-5HE10-4UF0

# SIMOTICS S-1FK2 servomotors

## SIMOTICS S-1FK2 servomotors for SINAMICS S210

### Technical specifications

#### Dimensional drawing

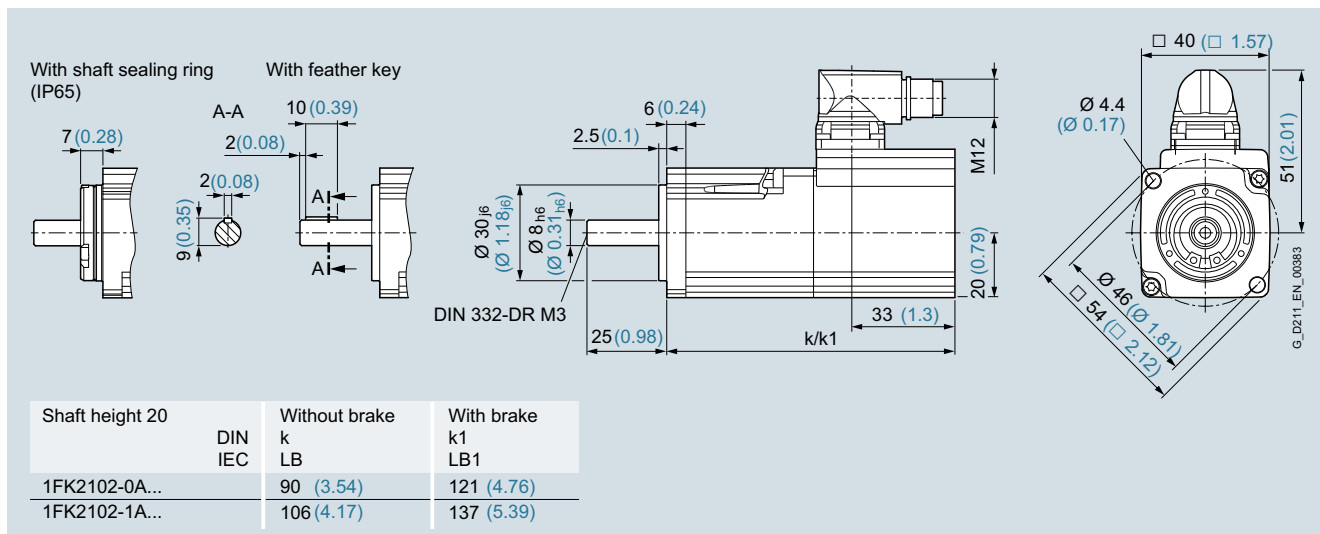

All dimensions in mm (values in brackets are in inches).

#### Speed/torque characteristics

High Dynamic

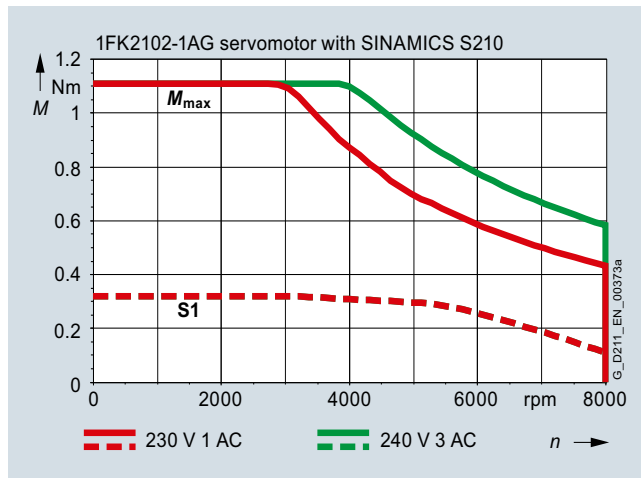
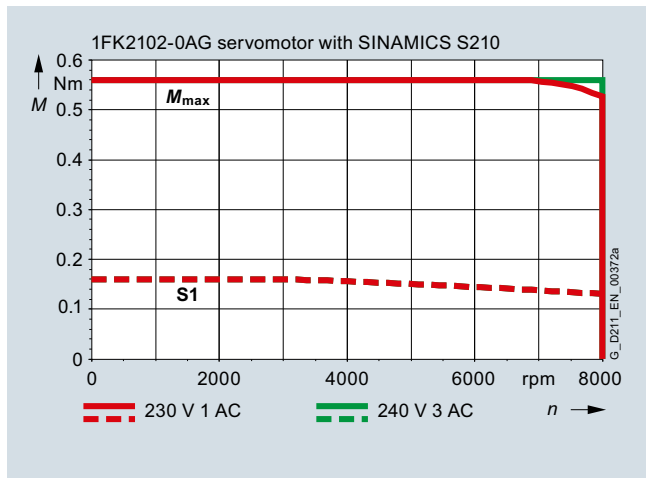

## Technical specifications

### SIMOTICS S-1FK2 shaft height 30

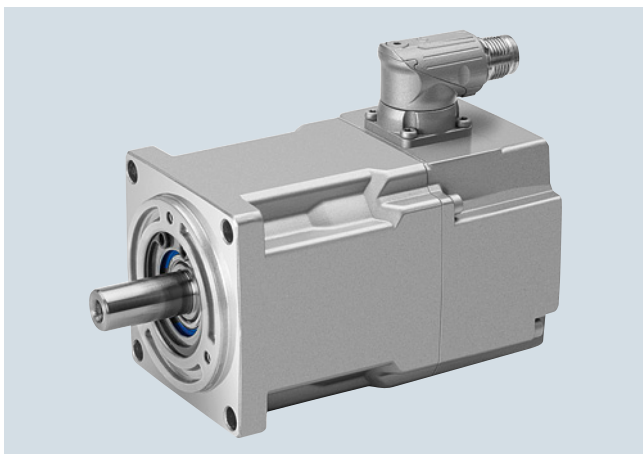

#### Specific technical specifications

SIMOTICS S-1FK2 servomotors		High Dynamic		Compact	
Shaft height 30		1FK2103-2AG	1FK2103-4AG	1FK2203-2AG	1FK2203-4AG
Static torque $M_0$	Nm (lb <sub>f</sub> -ft)	0.64 (0.47)	1.27 (0.94)	0.64 (0.47)	1.27 (0.94)
Stall current $I_0$	A	1.36	2.4	1.38	2.52
Maximum torque $M_{max}$	Nm (lb <sub>f</sub> -ft)	1.95 (1.44)	4.05 (2.99)	1.85 (1.36)	3.75 (2.77)
Maximum current $I_{max}$	A	4.8	8.7	4.2	7.8
Maximum speed $n_{max}$	rpm	8000	8000	8000	8000
Rotor moment of inertia $J_{Mot}$	kg cm <sup>2</sup> (lb <sub>f</sub> -in <sup>2</sup> )	0.093 (0.032)	0.14 (0.048)	0.20 (0.068)	0.35 (0.120)
Moment of inertia (with brake) $J_{Mot Br}$	kg cm <sup>2</sup> (lb <sub>f</sub> -in <sup>2</sup> )	0.11 (0.038)	0.16 (0.055)	0.22 (0.075)	0.37 (0.126)
Weight $m_{Mot}$	kg (lb)	1.16 (2.56)	1.63 (3.59)	1.1 (2.43)	1.57 (3.46)
Weight (with brake) $m_{Mot Br}$	kg (lb)	1.66 (3.66)	2.15 (4.74)	1.6 (3.53)	2.1 (4.63)
<b>200 ... 240 V 1 AC / 3 AC</b>					
Rated speed $n_{rated}$	rpm	3000	3000	3000	3000
Rated torque $M_{rated}$	Nm (lb <sub>f</sub> -ft)	0.64 (0.47)	1.27 (0.94)	0.64 (0.47)	1.27 (0.94)
Rated current $I_{rated}$	A	1.36	2.4	1.38	2.52
Rated power $P_{rated}$	W	200	400	200	400
Suitable for SINAMICS S210 servo converter					
• 200 ... 240 V 1 AC		6SL3210-5HB10-2UF0	6SL3210-5HB10-4UF0	6SL3210-5HB10-2UF0	6SL3210-5HB10-4UF0
• 200 ... 240 V 3 AC		6SL3210-5HE10-8UF0	6SL3210-5HE11-0UF0	6SL3210-5HE10-8UF0	6SL3210-5HE11-0UF0

# SIMOTICS S-1FK2 servomotors

## SIMOTICS S-1FK2 servomotors for SINAMICS S210

### Technical specifications

#### Dimensional drawing

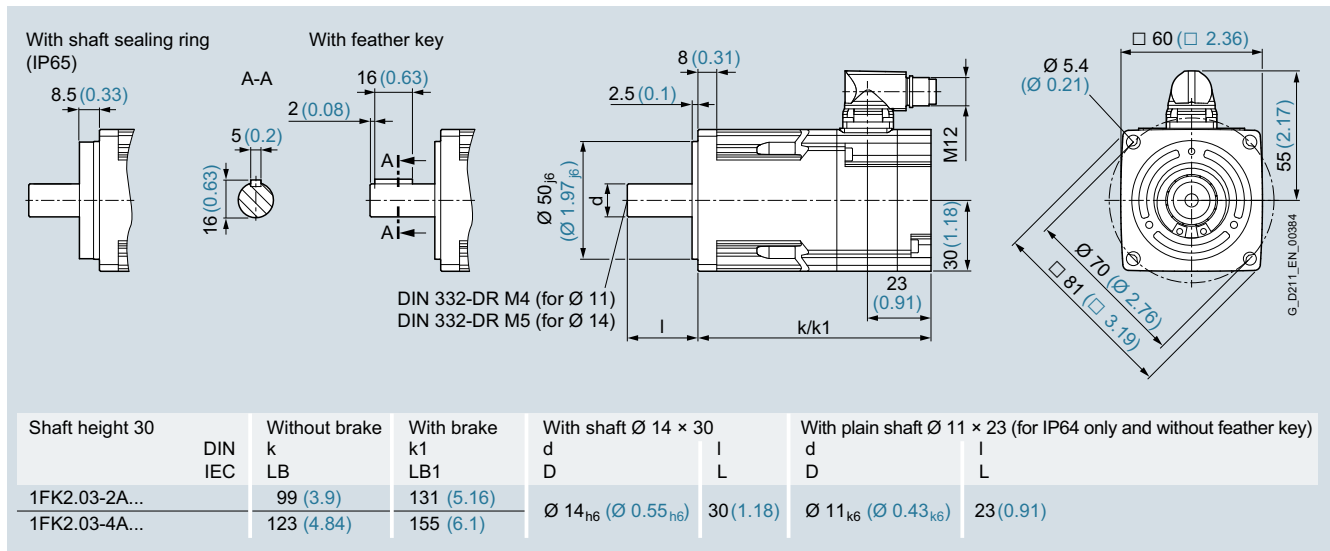

All dimensions in mm (values in brackets are in inches).

#### Speed/torque characteristics

##### High Dynamic

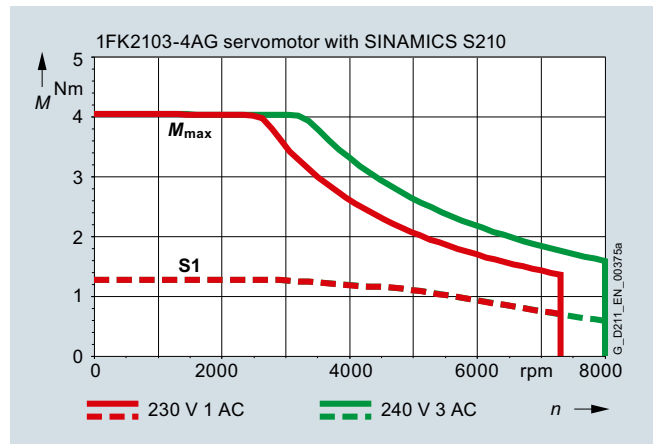
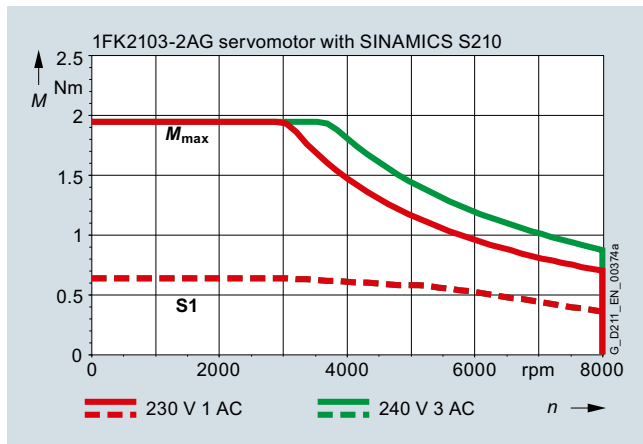

##### Compact

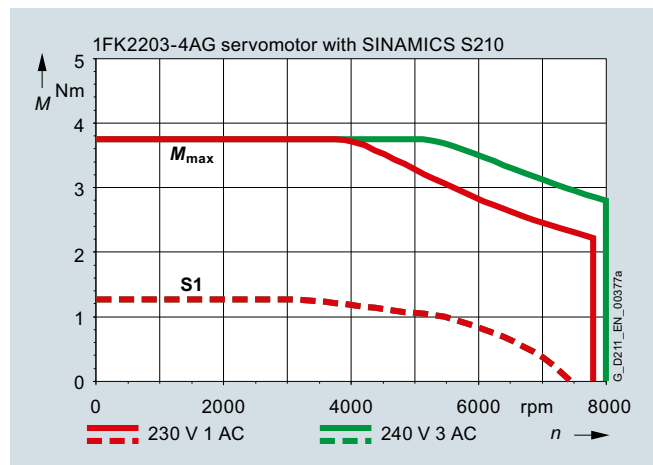
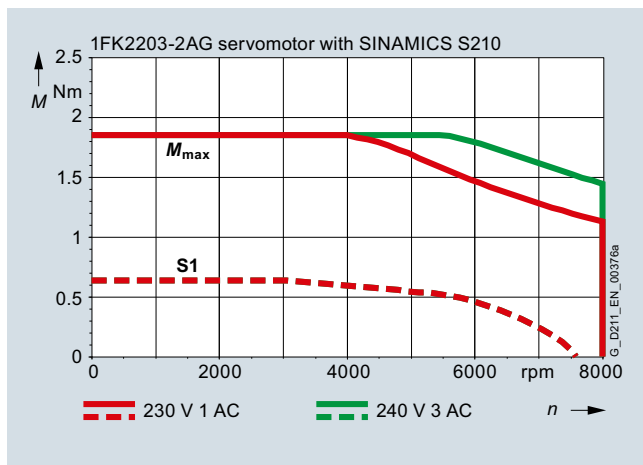

## Technical specifications

## SIMOTICS S-1FK2 shaft height 40

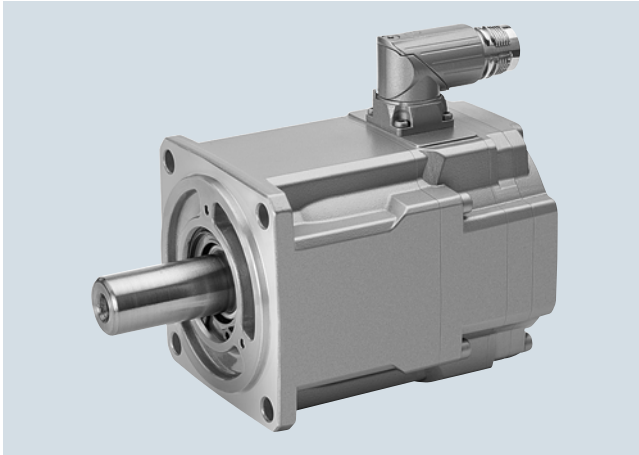

## Specific technical specifications

SIMOTICS S-1FK2 servomotors Shaft height 40		High Dynamic					Compact		
		1FK2104-4AF	1FK2104-4AK	1FK2104-5AF	1FK2104-5AK	1FK2104-6AF	1FK2204-5AF	1FK2204-5AK	1FK2204-6AF
Static torque $M_0$	Nm (lb <sub>f</sub> -ft)	1.27 (0.94)	1.27 (0.94)	2.4 (1.77)	2.4 (1.77)	3.2 (2.36)	2.4 (1.77)	2.4 (1.77)	3.2 (2.36)
Stall current $I_0$	A	1.19	2.4	2.1	4.4	3	2.25	4.4	3
Maximum torque $M_{max}$	Nm (lb <sub>f</sub> -ft)	3.75 (2.77)	3.85 (2.84)	7.5 (5.53)	7.6 (5.61)	10 (7.38)	7.1 (5.24)	7.1 (5.24)	9.5 (7.01)
Maximum current $I_{max}$	A	4.2	8.7	7.6	16	10.9	7.1	14.2	9.9
Maximum speed $n_{max}$	rpm	7200	8000	6700	8000	7200	7500	8000	7600
Rotor moment of inertia $J_{Mot}$	kg cm <sup>2</sup> (lb <sub>f</sub> -in <sup>2</sup> )	0.35 (0.120)	0.35 (0.120)	0.56 (0.191)	0.56 (0.191)	0.76 (0.260)	1.2 (0.410)	1.2 (0.410)	1.6 (0.547)
Moment of inertia (with brake) $J_{Mot Br}$	kg cm <sup>2</sup> (lb <sub>f</sub> -in <sup>2</sup> )	0.43 (0.147)	0.43 (0.147)	0.65 (0.222)	0.65 (0.222)	0.84 (0.287)	1.3 (0.444)	1.3 (0.444)	1.7 (0.581)
Weight $m_{Mot}$	kg (lb)	2.05 (4.52)	2.05 (4.52)	2.85 (6.28)	2.85 (6.28)	3.4 (7.50)	2.9 (6.39)	2.9 (6.39)	3.5 (7.72)
Weight (with brake) $m_{Mot Br}$	kg (lb)	2.9 (6.39)	2.9 (6.39)	3.7 (8.16)	3.7 (8.16)	4.25 (9.37)	3.75 (8.27)	3.75 (8.27)	4.25 (9.37)
<b>200 ... 240 V 1 AC / 3 AC</b>									
Rated speed $n_{rated}$	rpm	1500	3000	1500	3000	1500	1500	3000	1500
Rated torque $M_{rated}$	Nm (lb <sub>f</sub> -ft)	1.27 (0.94)	1.27 (0.94)	2.4 (1.77)	2.4 (1.77)	3.2 (2.36)	2.4 (1.77)	2.4 (1.77)	3.2 (2.36)
Rated current $I_{rated}$	A	1.19	2.4	2.1	4.4	3	2.25	4.4	3
Rated power $P_{rated}$	W	200	400	380	750	500	380	750	500
<b>380 ... 480 V 3 AC</b>									
Rated speed $n_{rated}$	rpm	3000	–	3000	–	3000	3000	6000	3000
Rated torque $M_{rated}$	Nm (lb <sub>f</sub> -ft)	1.27 (0.94)	–	2.4 (1.77)	–	3.2 (2.36)	2.4 (1.77)	0.9 (0.66)	3.2 (2.36)
Rated current $I_{rated}$	A	1.19	–	2.1	–	3	2.25	1.95	3
Rated power $P_{rated}$	W	400	–	750	–	1000	750	570	1000
Suitable for SINAMICS S210 servo converter									
• 200 ... 240 V 1 AC		6SL3210-5HB10-2UF0	6SL3210-5HB10-4UF0	6SL3210-5HB10-4UF0	6SL3210-5HB10-8UF0	6SL3210-5HB10-8UF0	6SL3210-5HB10-4UF0	6SL3210-5HB10-8UF0	6SL3210-5HB10-8UF0
• 200 ... 240 V 3 AC		6SL3210-5HE10-4UF0	6SL3210-5HE11-0UF0	6SL3210-5HE10-8UF0	6SL3210-5HE11-5UF0	6SL3210-5HE11-0UF0	6SL3210-5HE10-8UF0	6SL3210-5HE11-5UF0	6SL3210-5HE11-0UF0
• 380 ... 480 V 3 AC		6SL3210-5HE10-4UF0	–	6SL3210-5HE10-8UF0	–	6SL3210-5HE11-0UF0	6SL3210-5HE10-8UF0	6SL3210-5HE11-5UF0	6SL3210-5HE11-0UF0

# SIMOTICS S-1FK2 servomotors

## SIMOTICS S-1FK2 servomotors for SINAMICS S210

### Technical specifications

#### Dimensional drawing

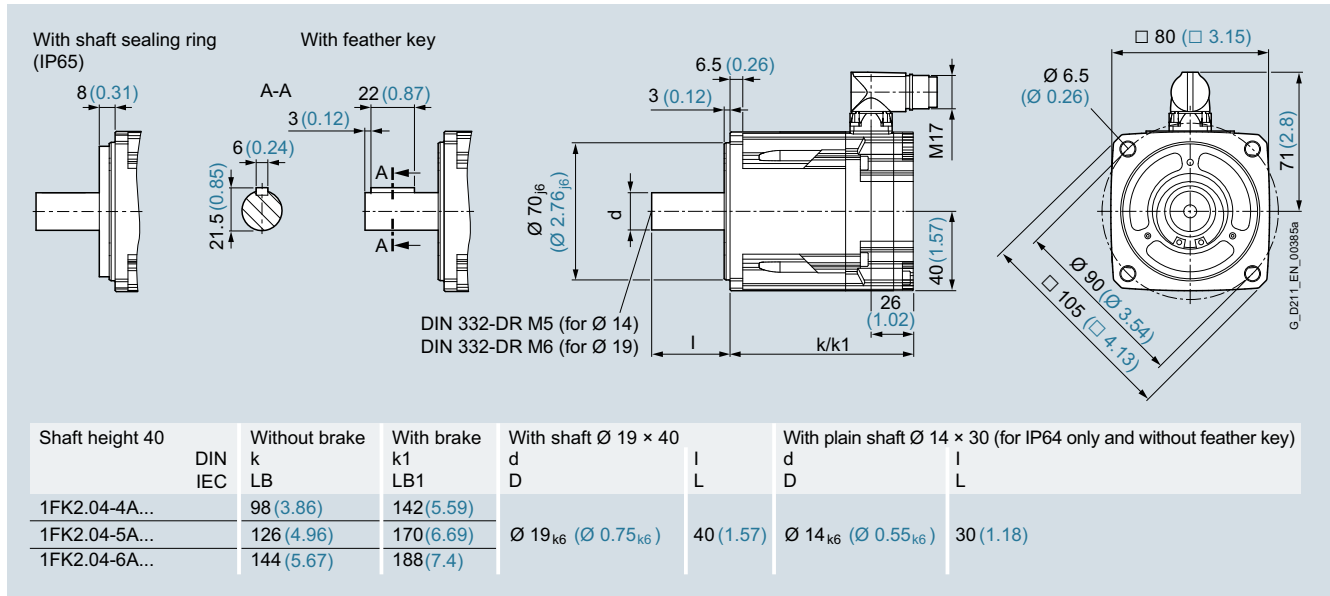

All dimensions in mm (values in brackets are in inches).

#### Speed/torque characteristics

##### High Dynamic

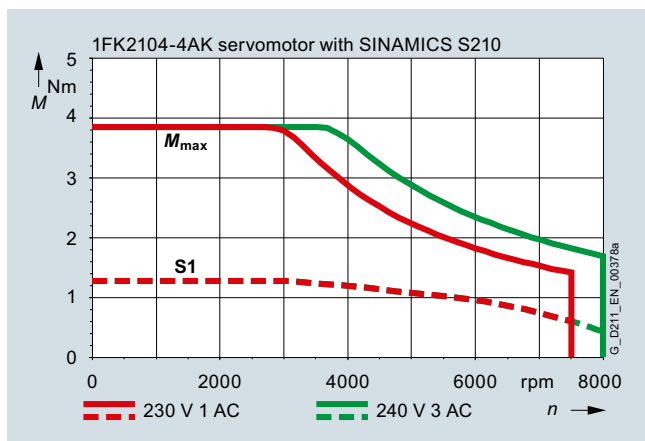
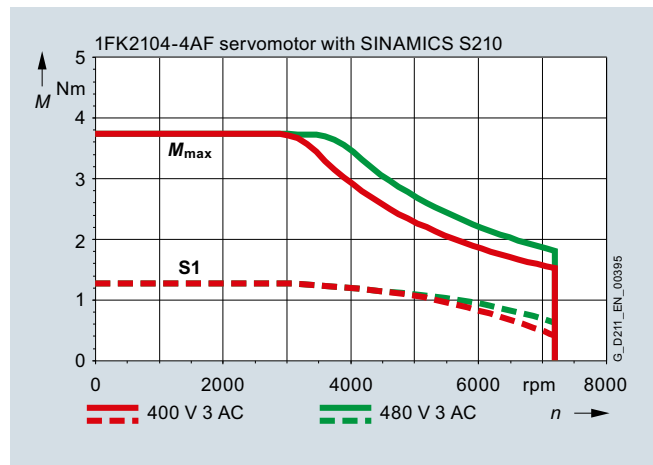
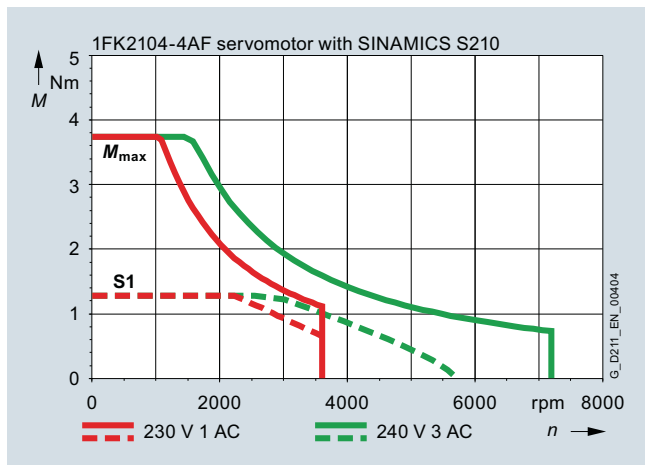



Technical specifications

Speed/torque characteristics (continued)

High Dynamic (continued)

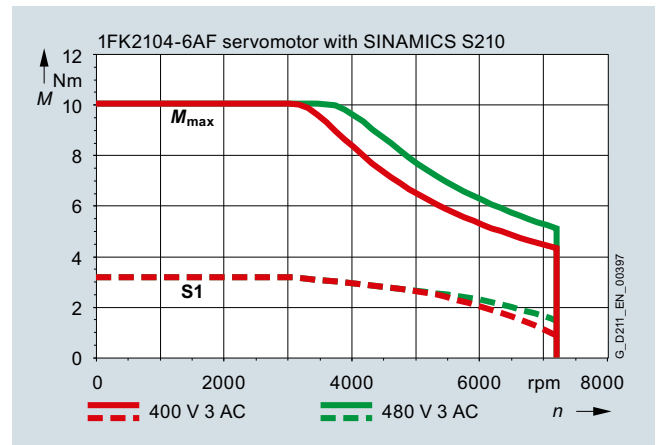
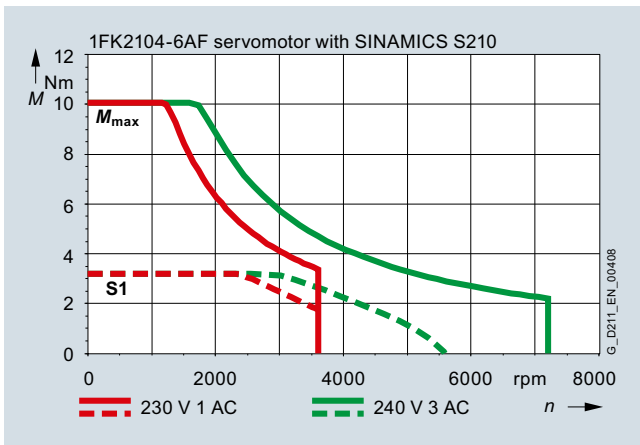
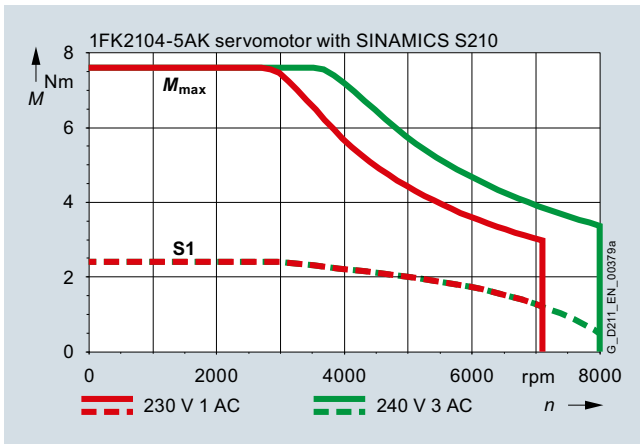
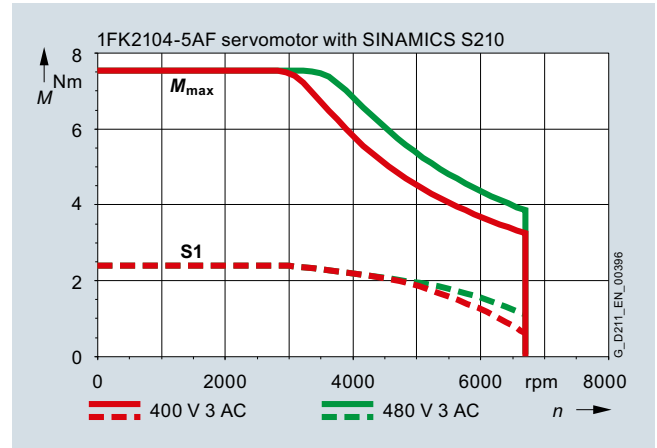
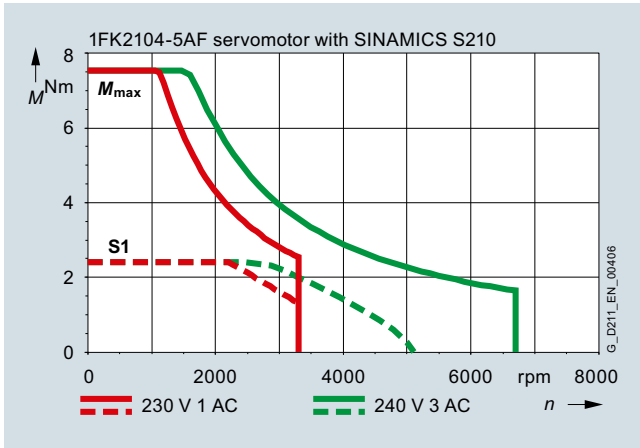

# SIMOTICS S-1FK2 servomotors

## SIMOTICS S-1FK2 servomotors for SINAMICS S210

### Technical specifications

#### Speed/torque characteristics (continued)

Compact

3

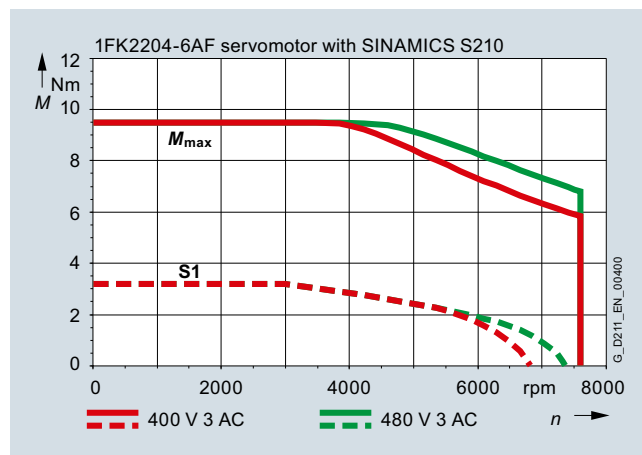
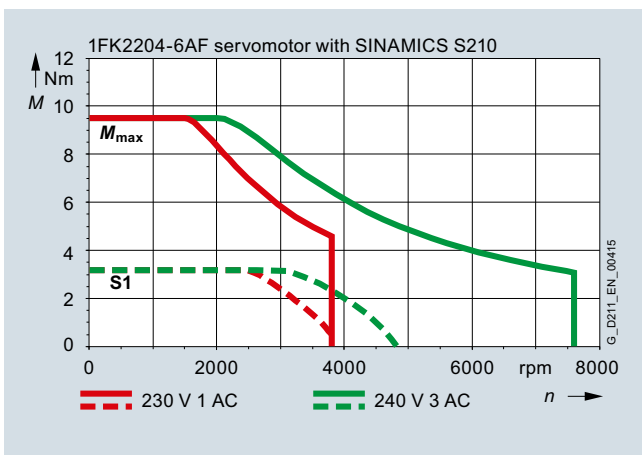
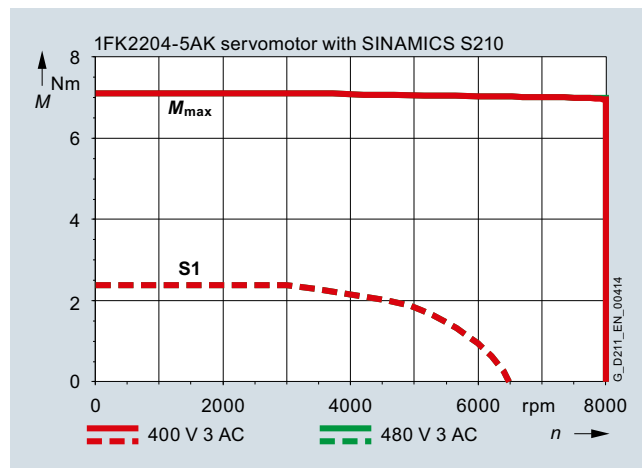
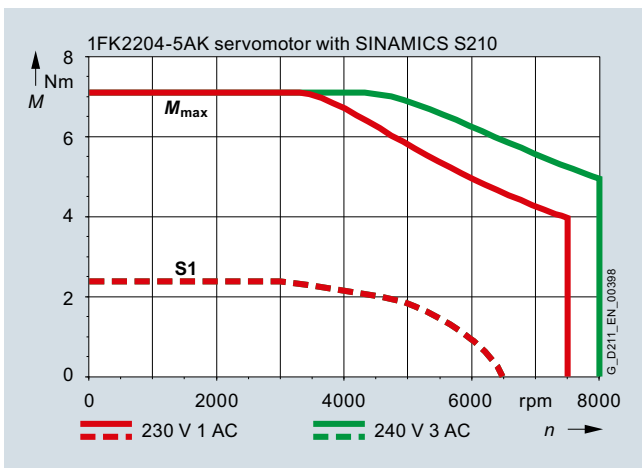
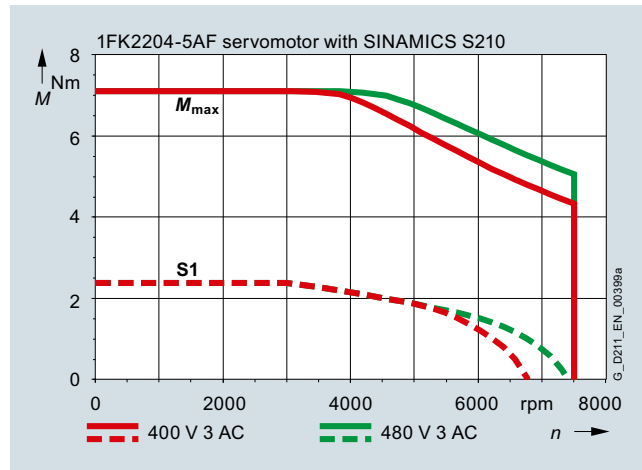
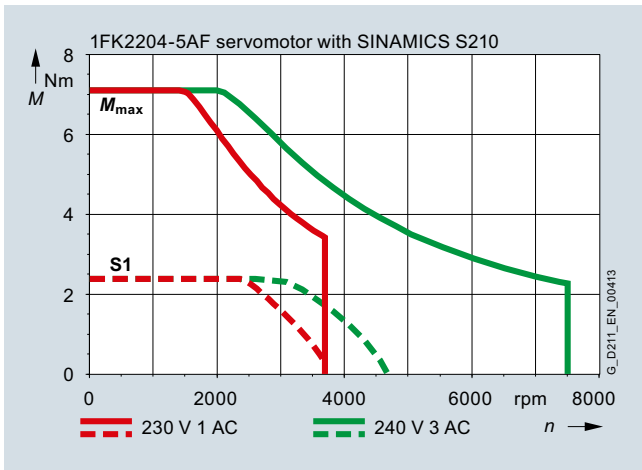

## Technical specifications

### SIMOTICS S-1FK2 shaft height 48

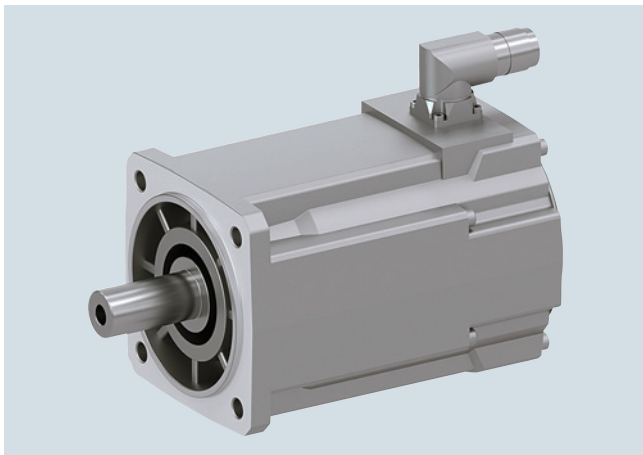

#### Specific technical specifications

SIMOTICS S-1FK2 servomotors		Compact	
Shaft height 48		1FK2205-2AF	1FK2205-4AF
Static torque $M_0$	Nm (lb <sub>r</sub> -ft)	3.6 (2.66)	6 (4.43)
Stall current $I_0$	A	2.9	4.7
Maximum torque $M_{max}$	Nm (lb <sub>r</sub> -ft)	10.8 (7.97)	18 (13.28)
Maximum current $I_{max}$	A	9.5	15.1
Maximum speed $n_{max}$	rpm	6000	6000
Rotor moment of inertia $J_{Mot}$	kg cm <sup>2</sup> (lb <sub>r</sub> -in <sup>2</sup> )	3.2 (1.093)	5.1 (1.743)
Moment of inertia (with brake) $J_{Mot Br}$	kg cm <sup>2</sup> (lb <sub>r</sub> -in <sup>2</sup> )	4.0 (1.367)	6.0 (2.050)
Weight $m_{Mot}$	kg (lb)	3.75 (8.27)	5.2 (11.47)
Weight (with brake) $m_{Mot Br}$	kg (lb)	4.75 (10.47)	6.2 (13.67)
<b>200 ... 240 V 1 AC / 3 AC</b>			
Rated speed $n_{rated}$	rpm	1500	1500
Rated torque $M_{rated}$	Nm (lb <sub>r</sub> -ft)	3.4 (2.51)	5.5 (4.06)
Rated current $I_{rated}$	A	2.8	4.35
Rated power $P_{rated}$	W	530	860
<b>380 ... 480 V 3 AC</b>			
Rated speed $n_{rated}$	rpm	3000	3000
Rated torque $M_{rated}$	Nm (lb <sub>r</sub> -ft)	3 (2.21)	4.6 (3.39)
Rated current $I_{rated}$	A	2.5	3.75
Rated power $P_{rated}$	W	940	1450
Suitable for SINAMICS S210 servo converter			
• 200 ... 240 V 1 AC		6SL3210-5HB10-8UF0	–
• 200 ... 240 V 3 AC		6SL3210-5HE11-0UF0	6SL3210-5HE11-5UF0
• 380 ... 480 V 3 AC		6SL3210-5HE11-0UF0	6SL3210-5HE11-5UF0

# SIMOTICS S-1FK2 servomotors

## SIMOTICS S-1FK2 servomotors for SINAMICS S210

### Technical specifications

#### Dimensional drawing

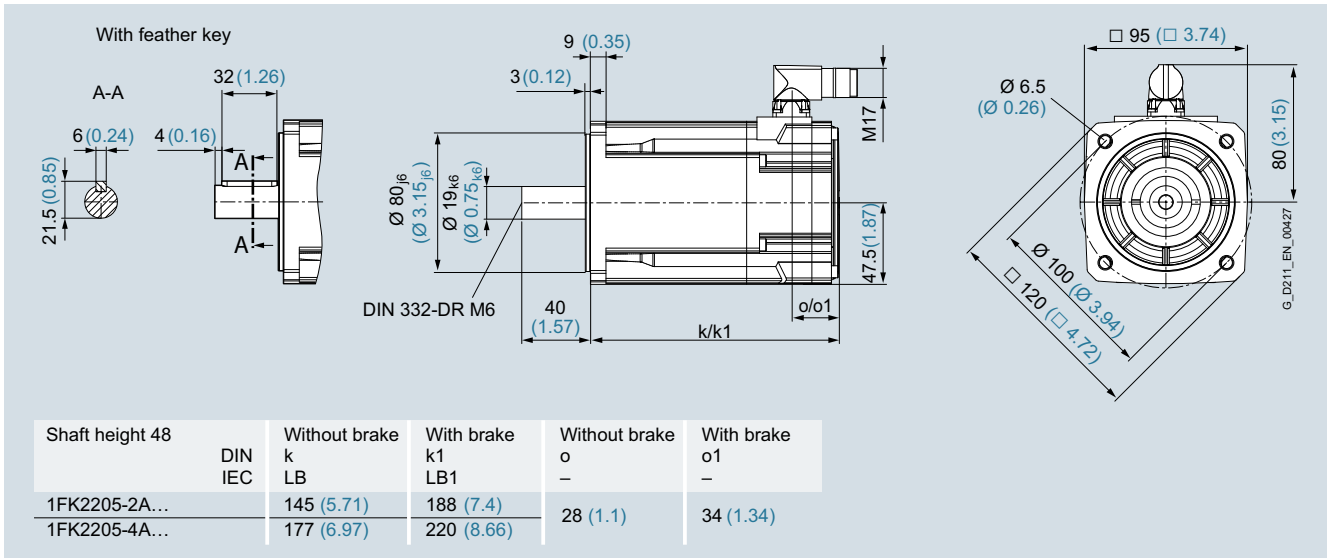

All dimensions in mm (values in brackets are in inches).

#### Speed/torque characteristics

##### Compact

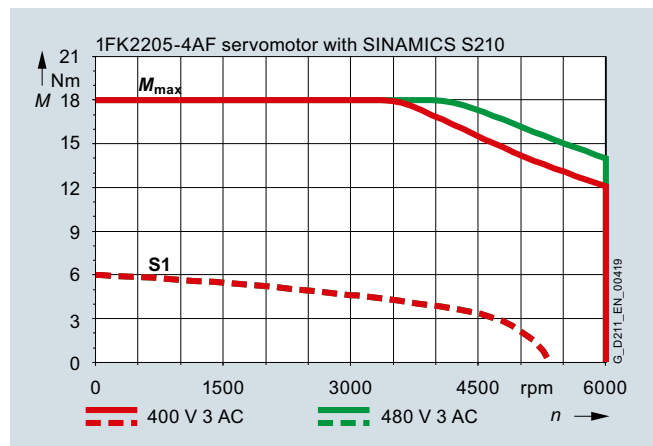
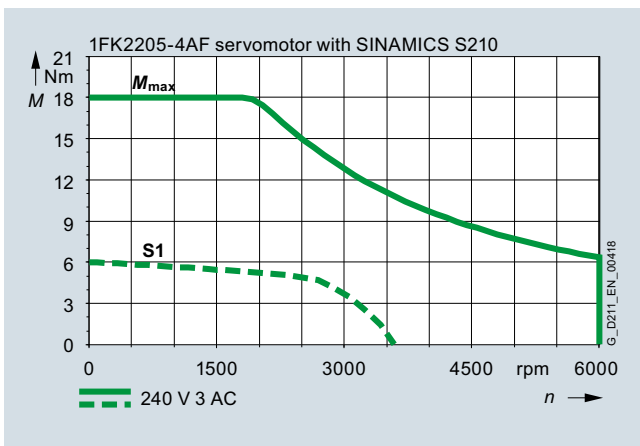
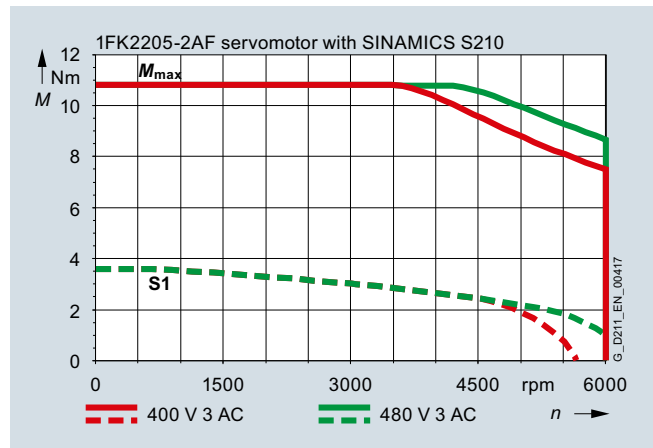
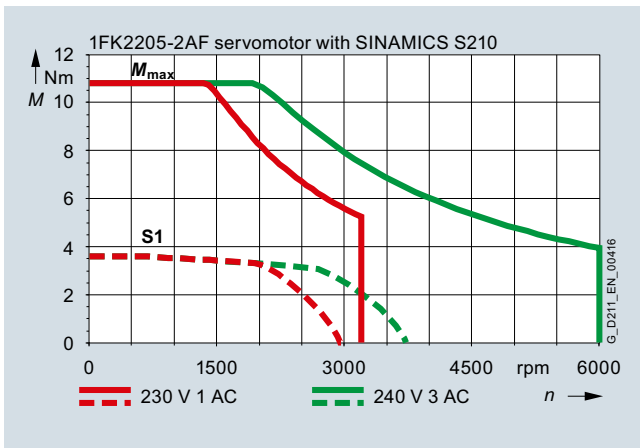

## Technical specifications

### SIMOTICS S-1FK2 shaft height 52

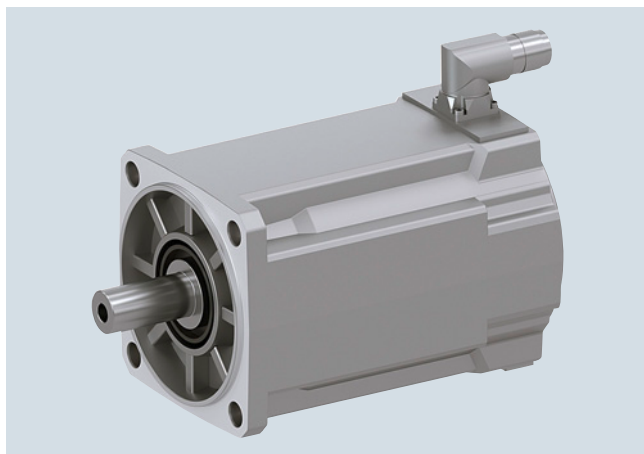

#### Specific technical specifications

SIMOTICS S-1FK2 servomotors		High Dynamic	
Shaft height 52		1FK2105-4AF	1FK2105-6AF
Static torque $M_0$	Nm (lb <sub>f</sub> -ft)	5 (3.69)	8 (5.90)
Stall current $I_0$	A	4.65	6.7
Maximum torque $M_{max}$	Nm (lb <sub>f</sub> -ft)	15 (11.06)	24 (17.70)
Maximum current $I_{max}$	A	18	24
Maximum speed $n_{max}$	rpm	6000	6000
Rotor moment of inertia $J_{Mot}$	kg cm <sup>2</sup> (lb <sub>f</sub> -in <sup>2</sup> )	1.7 (0.581)	2.7 (0.923)
Moment of inertia (with brake) $J_{Mot Br}$	kg cm <sup>2</sup> (lb <sub>f</sub> -in <sup>2</sup> )	2.6 (0.888)	3.5 (1.196)
Weight $m_{Mot}$	kg (lb)	5.6 (12.35)	7.7 (16.98)
Weight (with brake) $m_{Mot Br}$	kg (lb)	6.6 (14.55)	8.7 (19.18)
<b>200 ... 240 V 3 AC</b>			
Rated speed $n_{rated}$	rpm	1500	1500
Rated torque $M_{rated}$	Nm (lb <sub>f</sub> -ft)	5 (3.69)	8 (5.90)
Rated current $I_{rated}$	A	4.65	6.7
Rated power $P_{rated}$	W	790	1260
<b>380 ... 480 V 3 AC</b>			
Rated speed $n_{rated}$	rpm	3000	3000
Rated torque $M_{rated}$	Nm (lb <sub>f</sub> -ft)	4.6 (3.39)	6.6 (4.87)
Rated current $I_{rated}$	A	4.35	5.6
Rated power $P_{rated}$	W	1450	2100
Suitable for SINAMICS S210 servo converter			
• 200 ... 240 V 3 AC		6SL3210-5HE11-5UF0	6SL3210-5HE12-0UF0
• 380 ... 480 V 3 AC		6SL3210-5HE11-5UF0	6SL3210-5HE12-0UF0

# SIMOTICS S-1FK2 servomotors

## SIMOTICS S-1FK2 servomotors for SINAMICS S210

### Technical specifications

#### Dimensional drawing

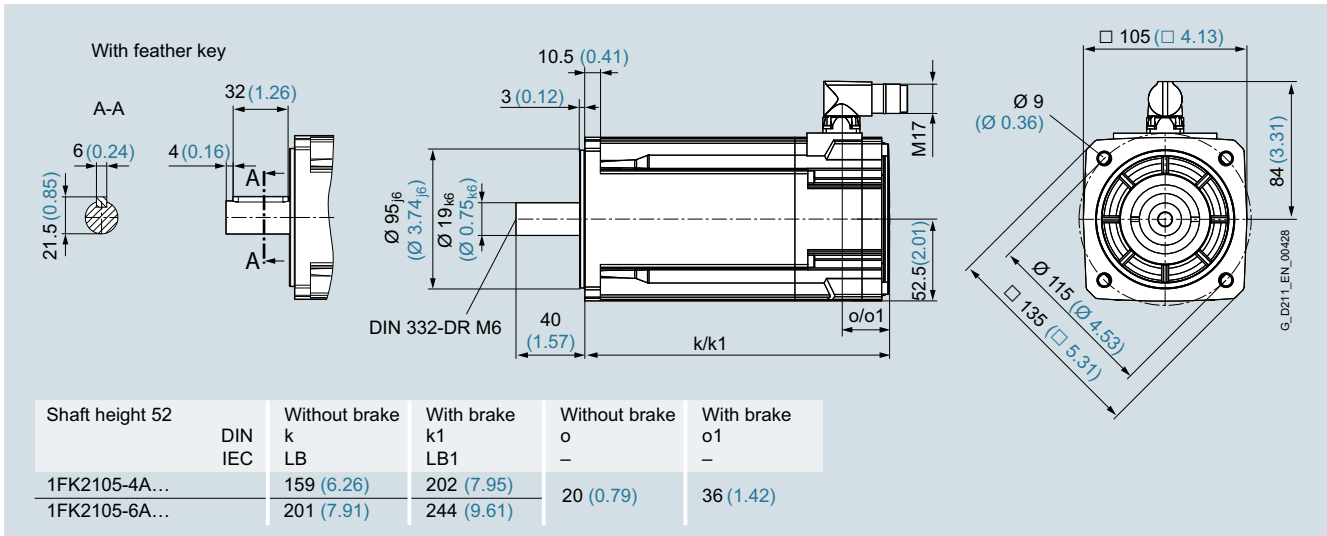

All dimensions in mm (values in brackets are in inches).

#### Speed/torque characteristics

##### High Dynamic

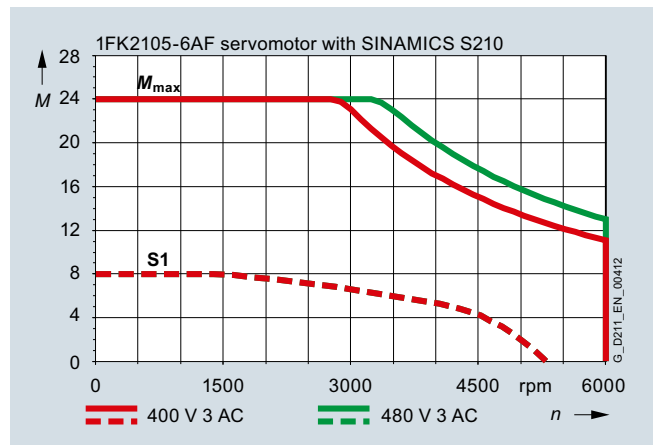
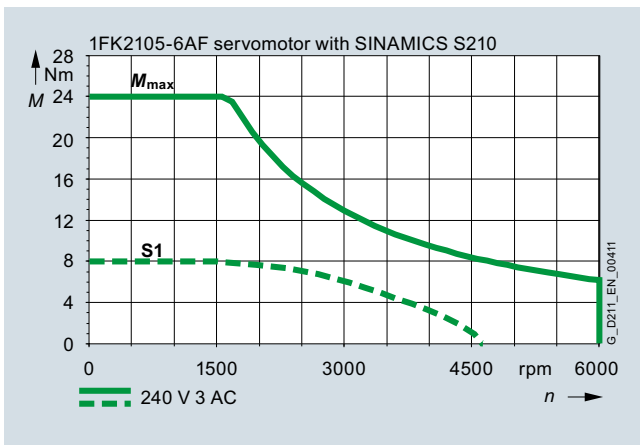
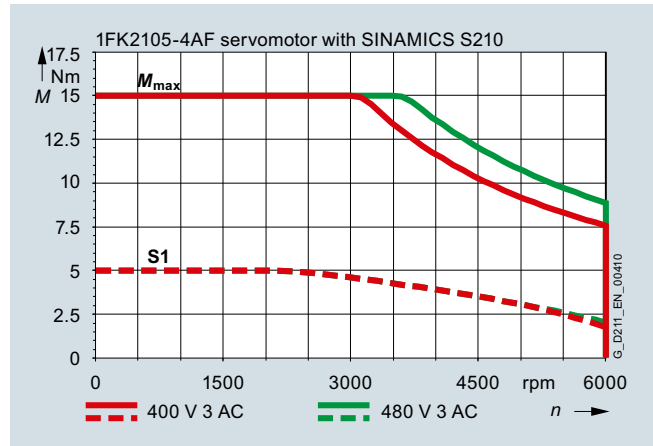
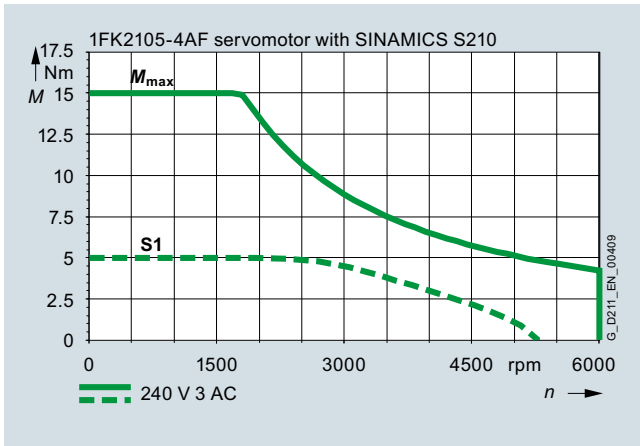

## Technical specifications

### SIMOTICS S-1FK2 shaft height 63

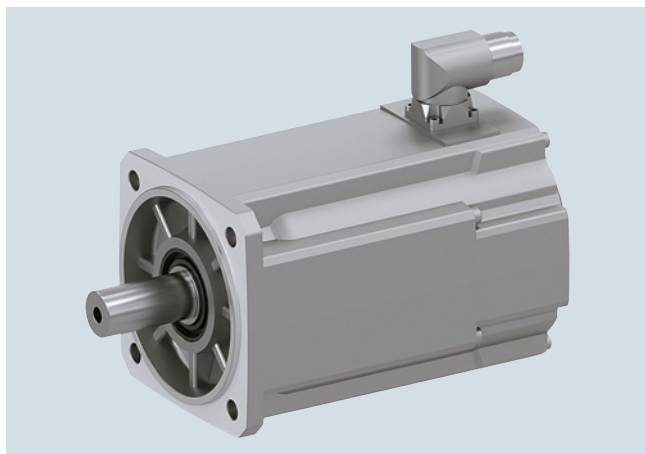

#### Specific technical specifications

SIMOTICS S-1FK2 servomotors Shaft height 63		High Dynamic			Compact	
		1FK2106-3AF	1FK2106-4AF	1FK2106-6AF	1FK2206-2AF	1FK2206-4AF
Static torque $M_0$	Nm (lb <sub>f</sub> -ft)	9 (6.64)	12 (8.85)	16 (11.80)	6.5 (4.79)	12 (8.85)
Stall current $I_0$	A	9.2	10.7	14.3	5	7.9
Maximum torque $M_{max}$	Nm (lb <sub>f</sub> -ft)	24.5 (18.07)	32.5 (23.97)	42 (30.98)	18 (13.28)	36 (26.55)
Maximum current $I_{max}$	A	36	40	44	17.8	29.5
Maximum speed $n_{max}$	rpm	6000	6000	6000	6000	5800
Rotor moment of inertia $J_{Mot}$	kg cm <sup>2</sup> (lb <sub>f</sub> -in <sup>2</sup> )	4.6 (1.572)	6.0 (2.050)	8.7 (2.973)	7.8 (2.665)	15 (5.126)
Moment of inertia (with brake) $J_{Mot Br}$	kg cm <sup>2</sup> (lb <sub>f</sub> -in <sup>2</sup> )	6.3 (2.153)	7.6 (2.597)	10 (3.417)	9.4 (3.212)	17 (5.809)
Weight $m_{Mot}$	kg (lb)	7.4 (16.32)	9 (19.85)	11.8 (26.02)	6.3 (13.89)	8.9 (19.62)
Weight (with brake) $m_{Mot Br}$	kg (lb)	9 (19.85)	10.6 (23.37)	13.4 (29.55)	7.9 (17.42)	10.6 (23.37)
<b>200 ... 240 V 3 AC</b>						
Rated speed $n_{rated}$	rpm	1500	1500	1500	1500	1500
Rated torque $M_{rated}$	Nm (lb <sub>f</sub> -ft)	8.3 (6.12)	10.5 (7.74)	13.8 (10.18)	6.1 (4.50)	10.9 (8.04)
Rated current $I_{rated}$	A	8.7	9.6	12.5	4.8	7.3
Rated power $P_{rated}$	W	1300	1640	2150	970	1720
<b>380 ... 480 V 3 AC</b>						
Rated speed $n_{rated}$	rpm	3000	3000	3000	3000	3000
Rated torque $M_{rated}$	Nm (lb <sub>f</sub> -ft)	7.3 (5.38)	8.6 (6.34)	10.6 (7.82)	5.4 (3.98)	9.1 (6.71)
Rated current $I_{rated}$	A	7.9	8.1	9.7	4.35	6.2
Rated power $P_{rated}$	W	2300	2700	3300	1710	2850
Suitable for SINAMICS S210 servo converter						
• 200 ... 240 V 3 AC		6SL3210-5HE15-0UF0	6SL3210-5HE15-0UF0	6SL3210-5HE17-0UF0	6SL3210-5HE11-5UF0	6SL3210-5HE13-5UF0
• 380 ... 480 V 3 AC		6SL3210-5HE15-0UF0	6SL3210-5HE15-0UF0	6SL3210-5HE17-0UF0	6SL3210-5HE11-5UF0	6SL3210-5HE13-5UF0

# SIMOTICS S-1FK2 servomotors

## SIMOTICS S-1FK2 servomotors for SINAMICS S210

### Technical specifications

#### Dimensional drawing

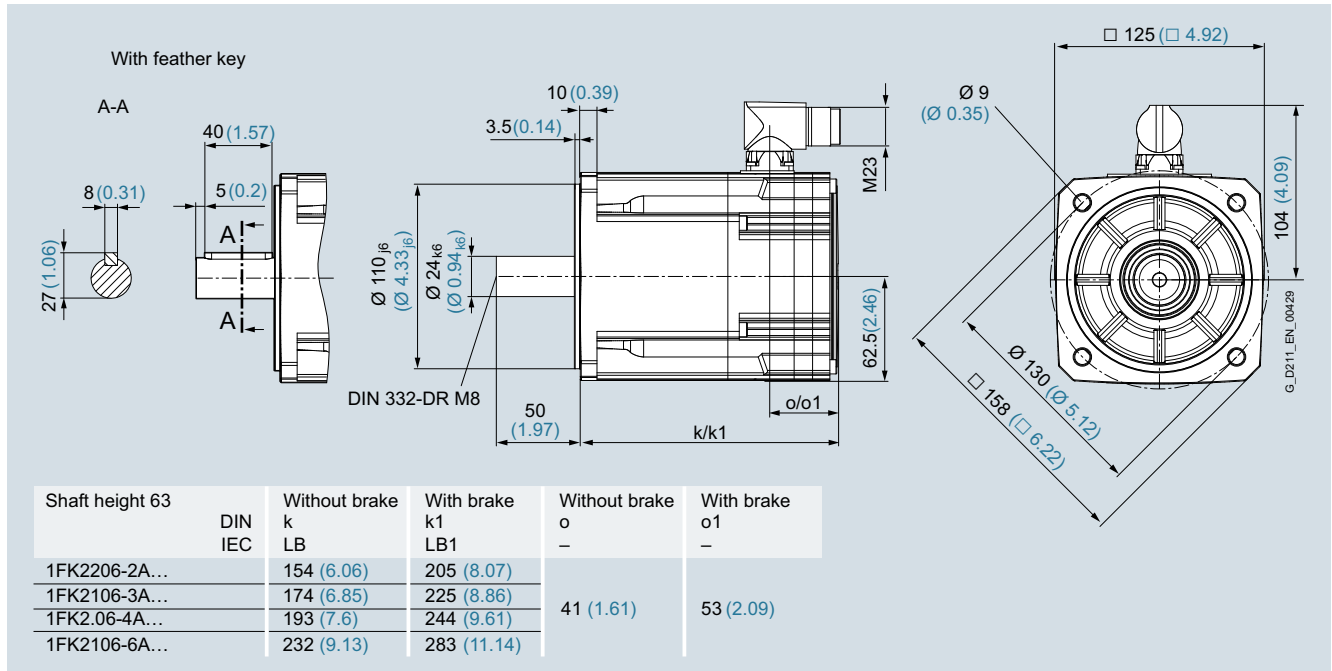

All dimensions in mm (values in brackets are in inches).

#### Speed/torque characteristics

##### High Dynamic

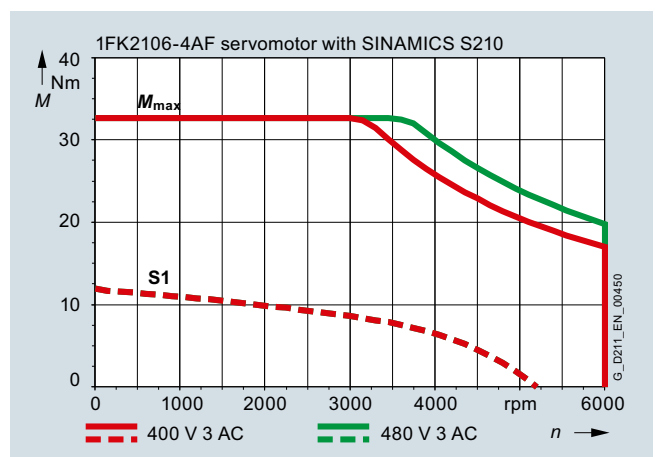
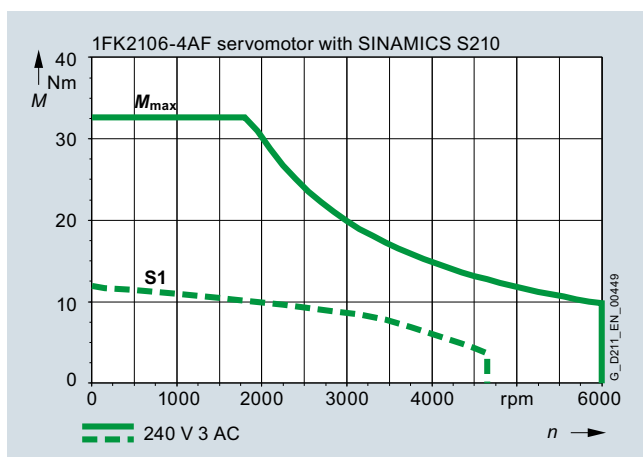
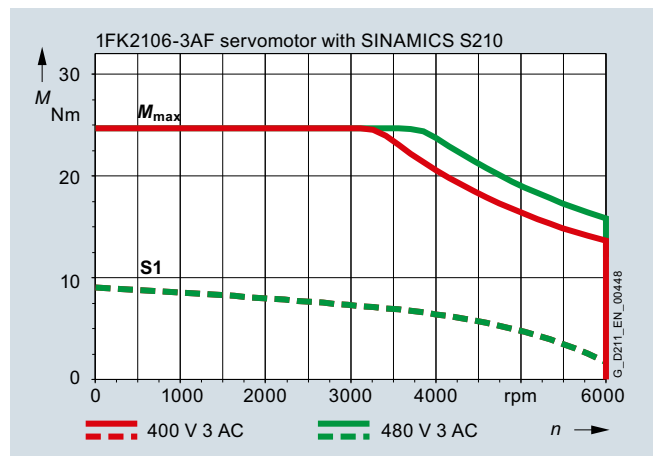
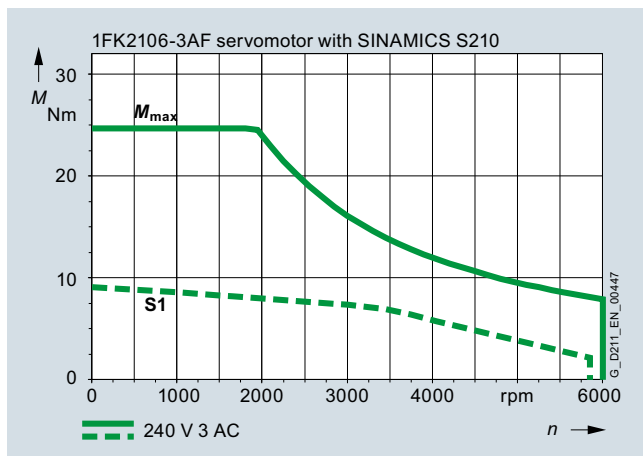



Technical specifications

Speed/torque characteristics (continued)

High Dynamic (continued)

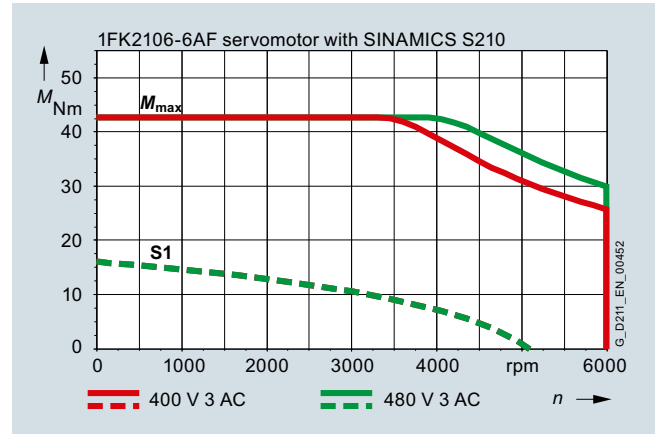
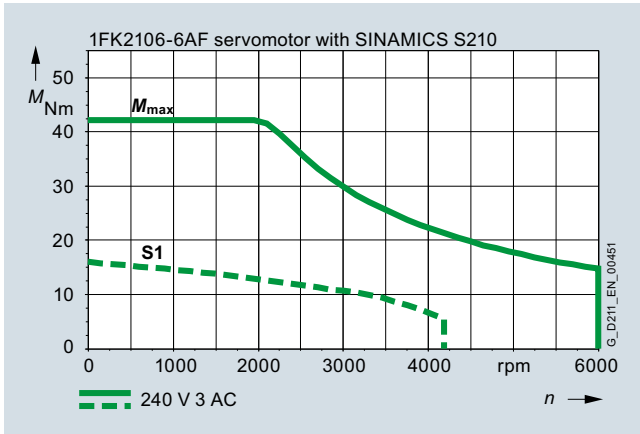

Compact

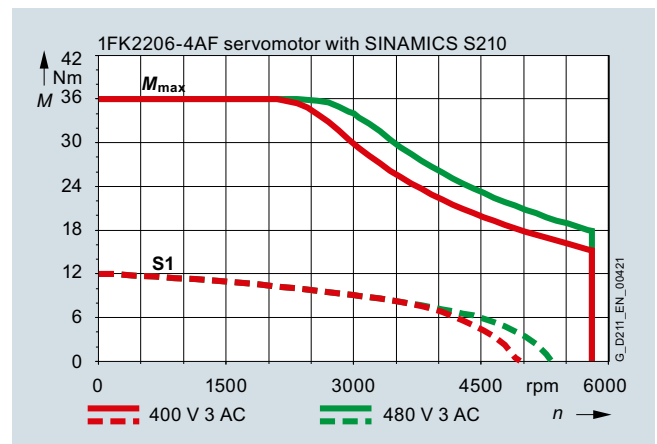
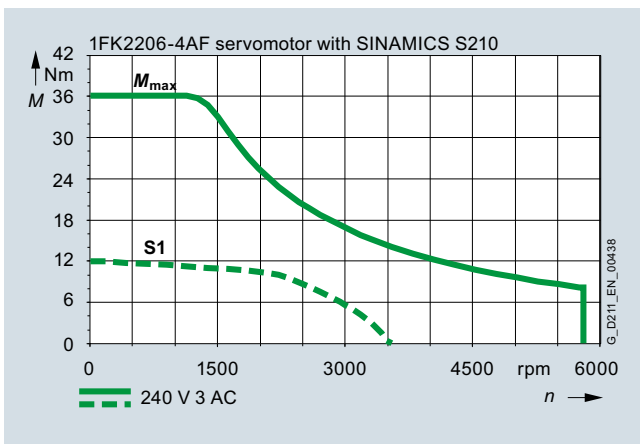
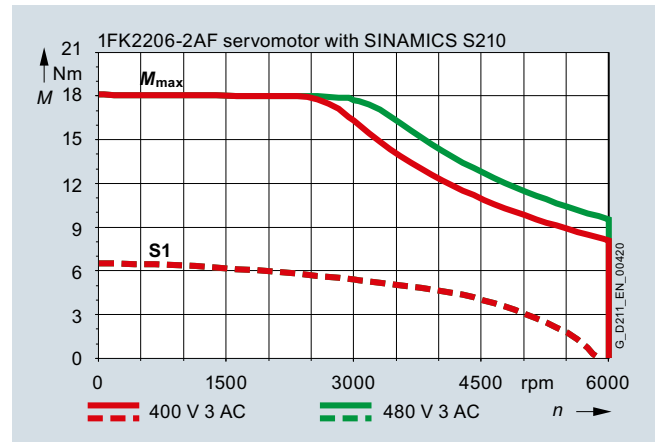
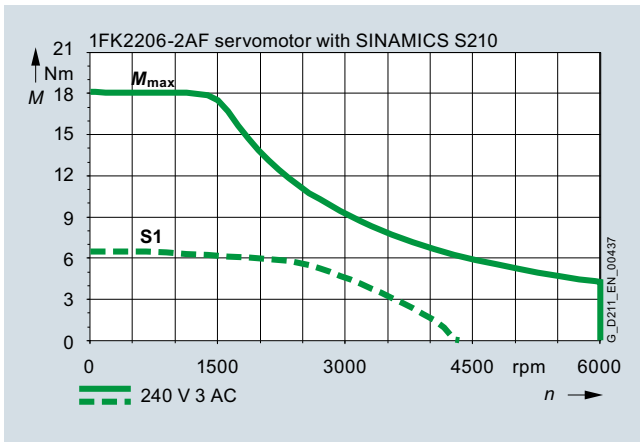

## SIMOTICS S-1FK2 servomotors

### SIMOTICS S-1FK2 servomotors for SINAMICS S210

#### Technical specifications

##### SIMOTICS S-1FK2 shaft height 80

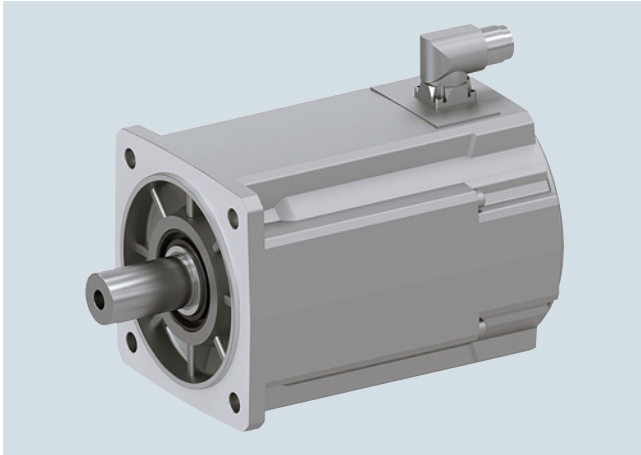

#### Specific technical specifications

SIMOTICS S-1FK2 servomotors		Compact		
Shaft height 80		1FK2208-3AC	1FK2208-4AC	1FK2208-5AC
Static torque $M_0$	Nm (lb <sub>r</sub> -ft)	18 (13.28)	22 (16.23)	27 (19.92)
Stall current $I_0$	A	8.4	11.7	14.6
Maximum torque $M_{max}$	Nm (lb <sub>r</sub> -ft)	51 (37.62)	66 (48.68)	80 (59.01)
Maximum current $I_{max}$	A	29.5	43.5	51.5
Maximum speed $n_{max}$	rpm	4100	4600	4700
Rotor moment of inertia $J_{Mot}$	kg cm <sup>2</sup> (lb <sub>r</sub> -in <sup>2</sup> )	30 (10.251)	39 (13.326)	48 (16.402)
Moment of inertia (with brake) $J_{Mot Br}$	kg cm <sup>2</sup> (lb <sub>r</sub> -in <sup>2</sup> )	33 (11.276)	44 (15.035)	54 (18.452)
Weight $m_{Mot}$	kg (lb)	12.6 (27.78)	14.6 (32.19)	16.6 (36.60)
Weight (with brake) $m_{Mot Br}$	kg (lb)	14.6 (32.19)	17.3 (38.15)	19.3 (42.56)
<b>200 ... 240 V 3 AC</b>				
Rated speed $n_{rated}$	rpm	1000	1000	1000
Rated torque $M_{rated}$	Nm (lb <sub>r</sub> -ft)	16.6 (12.24)	20 (14.75)	23.5 (17.33)
Rated current $I_{rated}$	A	7.9	10.9	13.2
Rated power $P_{rated}$	W	1740	2150	2500
<b>380 ... 480 V 3 AC</b>				
Rated speed $n_{rated}$	rpm	2000	2000	2000
Rated torque $M_{rated}$	Nm (lb <sub>r</sub> -ft)	14.5 (10.70)	17 (12.54)	19.1 (14.09)
Rated current $I_{rated}$	A	7	9.3	10.8
Rated power $P_{rated}$	W	3050	3550	4000
Suitable for SINAMICS S210 servo converter				
• 200 ... 240 V 3 AC		6SL3210-5HE13-5UF0	6SL3210-5HE15-0UF0	6SL3210-5HE17-0UF0
• 380 ... 480 V 3 AC		6SL3210-5HE13-5UF0	6SL3210-5HE15-0UF0	6SL3210-5HE17-0UF0

**Technical specifications**

Dimensional drawing

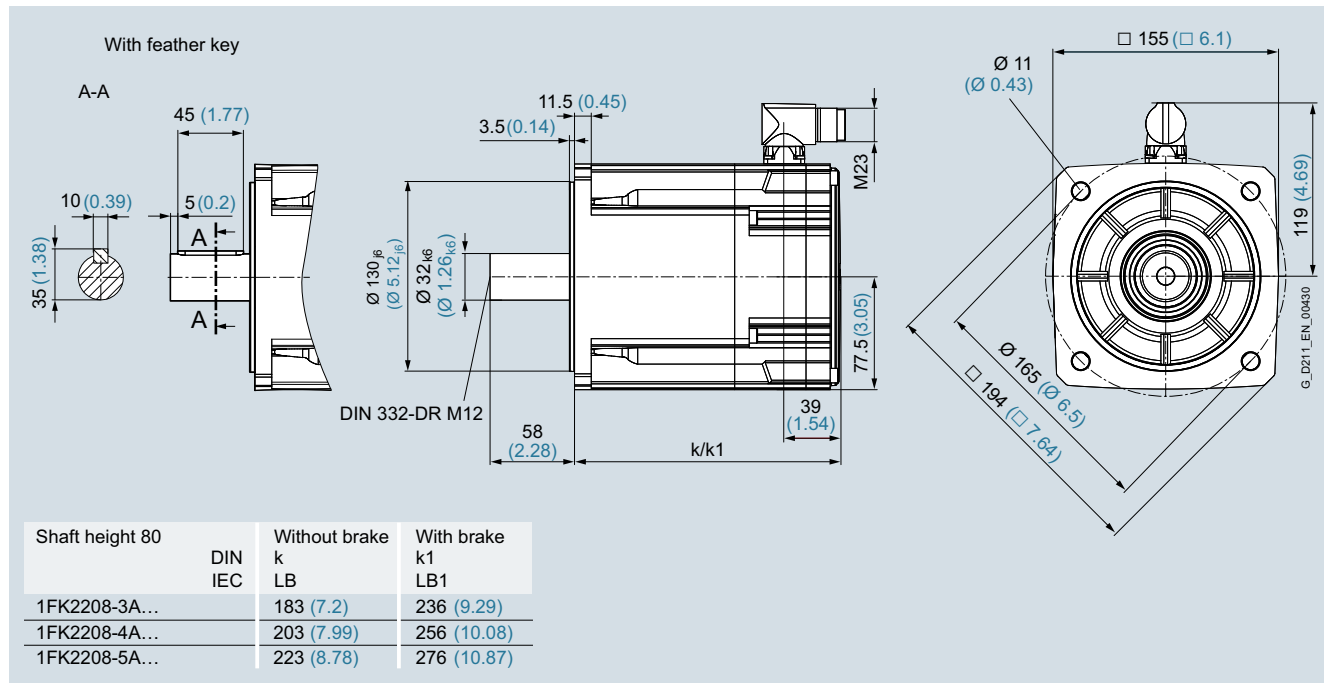

All dimensions in mm (values in brackets are in inches).

# SIMOTICS S-1FK2 servomotors

## SIMOTICS S-1FK2 servomotors for SINAMICS S210

### Technical specifications

#### Speed/torque characteristics

Compact

3

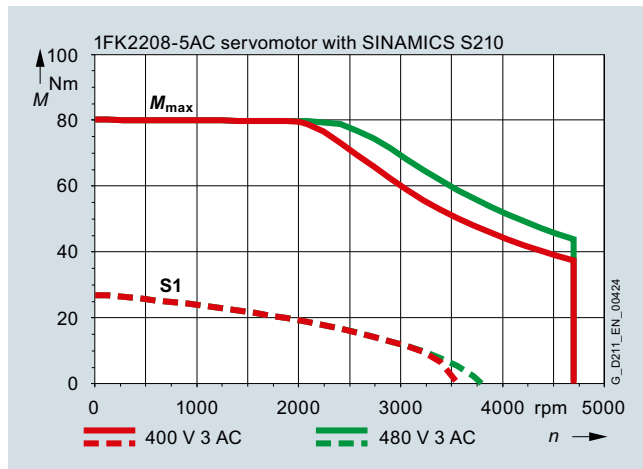
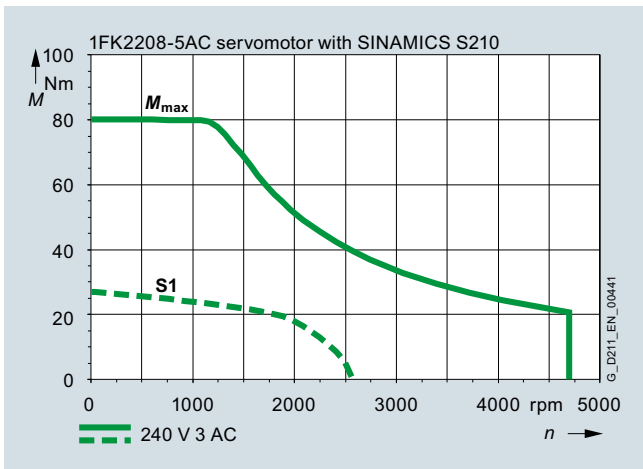
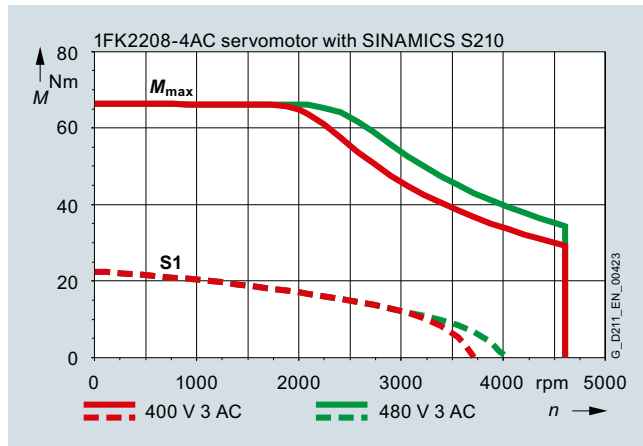
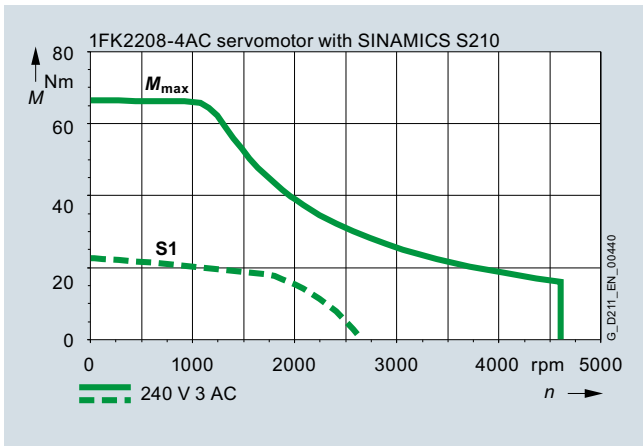
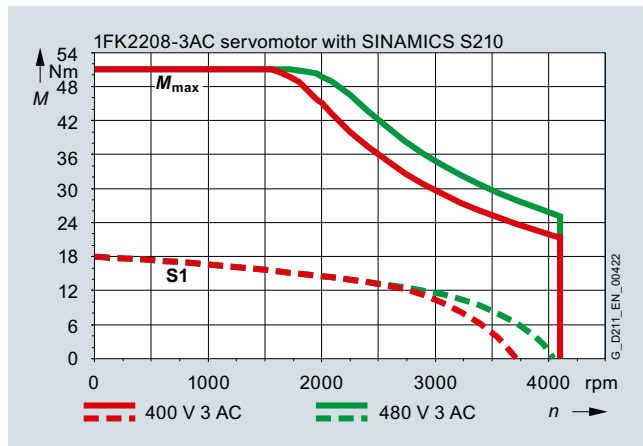
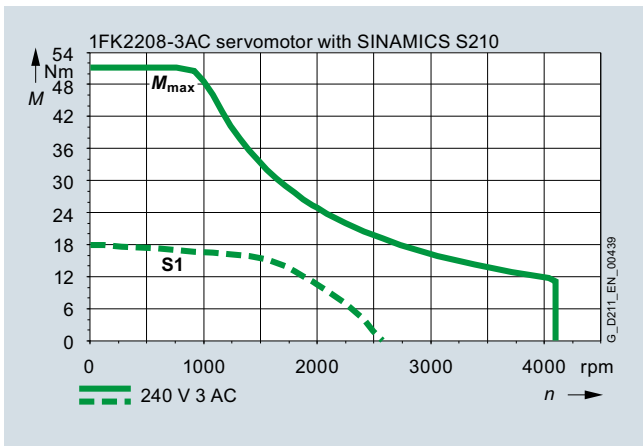

## Technical specifications

### SIMOTICS S-1FK2 shaft height 100

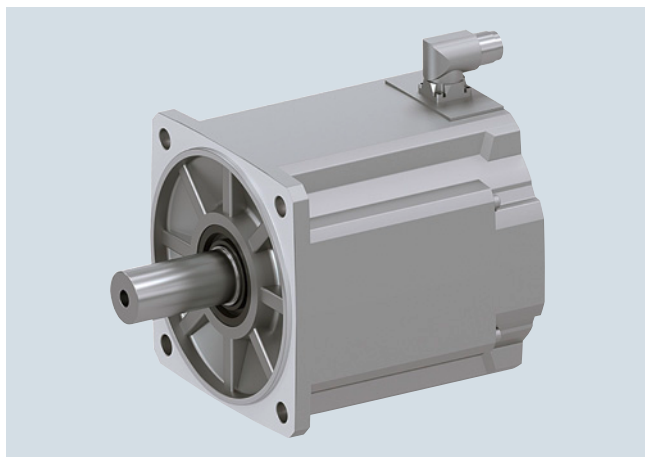

#### Specific technical specifications

SIMOTICS S-1FK2 servomotors		Compact			
Shaft height 100		1FK2210-3AB	1FK2210-3AC	1FK2210-4AB	1FK2210-4AC
Static torque $M_0$	Nm (lb <sub>r</sub> -ft)	30 (22.13)	30 (22.13)	40 (29.50)	40 (29.50)
Stall current $I_0$	A	8.5	15	11.8	15
Maximum torque $M_{max}$	Nm (lb <sub>r</sub> -ft)	90 (66.38)	90 (66.38)	120 (88.51)	120 (88.51)
Maximum current $I_{max}$	A	31.5	55	43.5	55
Maximum speed $n_{max}$	rpm	2500	4400	2500	3300
Rotor moment of inertia $J_{Mot}$	kg cm <sup>2</sup> (lb <sub>r</sub> -in <sup>2</sup> )	89 (30.411)	89 (30.411)	120 (41.004)	120 (41.004)
Moment of inertia (with brake) $J_{Mot Br}$	kg cm <sup>2</sup> (lb <sub>r</sub> -in <sup>2</sup> )	95 (32.462)	95 (32.462)	130 (44.421)	130 (44.421)
Weight $m_{Mot}$	kg (lb)	22 (48.51)	22 (48.51)	27 (59.54)	27 (59.54)
Weight (with brake) $m_{Mot Br}$	kg (lb)	25 (55.13)	25 (55.13)	31 (68.36)	31 (68.36)
<b>200 ... 240 V 3 AC</b>					
Rated speed $n_{rated}$	rpm	750	1000	750	1000
Rated torque $M_{rated}$	Nm (lb <sub>r</sub> -ft)	30 (22.13)	30 (22.13)	39 (28.77)	37 (27.29)
Rated current $I_{rated}$	A	8.6	15.5	11.6	14.3
Rated power $P_{rated}$	W	2500	3200	3050	3900
<b>380 ... 480 V 3 AC</b>					
Rated speed $n_{rated}$	rpm	1500	2000	1500	2000
Rated torque $M_{rated}$	Nm (lb <sub>r</sub> -ft)	28.5 (21.02)	26 (19.18)	34.5 (25.45)	30.5 (22.50)
Rated current $I_{rated}$	A	8.3	13.5	10.4	11.8
Rated power $P_{rated}$	W	4500	5500	5400	6400
Suitable for SINAMICS S210 servo converter					
• 200 ... 240 V 3 AC		6SL3210-5HE13-5UF0	6SL3210-5HE17-0UF0	6SL3210-5HE15-0UF0	6SL3210-5HE17-0UF0
• 380 ... 480 V 3 AC		6SL3210-5HE13-5UF0	6SL3210-5HE17-0UF0	6SL3210-5HE15-0UF0	6SL3210-5HE17-0UF0

# SIMOTICS S-1FK2 servomotors

## SIMOTICS S-1FK2 servomotors for SINAMICS S210

### Technical specifications

#### Dimensional drawing

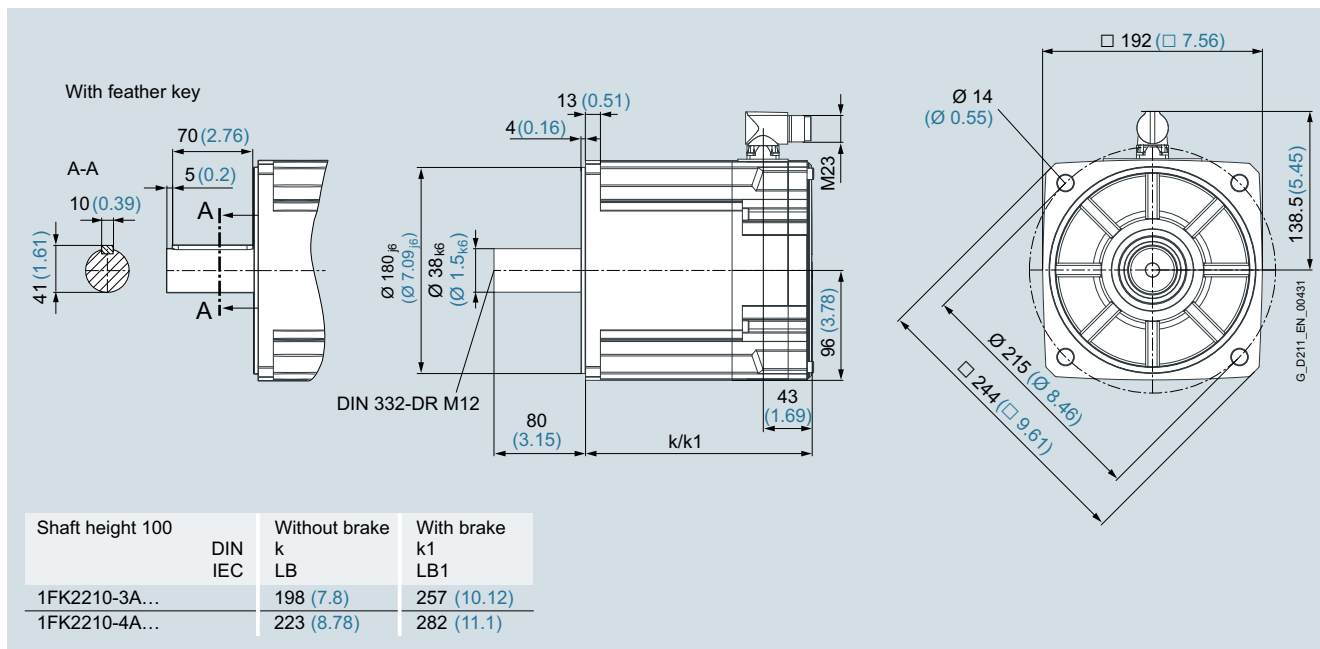

All dimensions in mm (values in brackets are in inches).

Technical specifications

Speed/torque characteristics

Compact

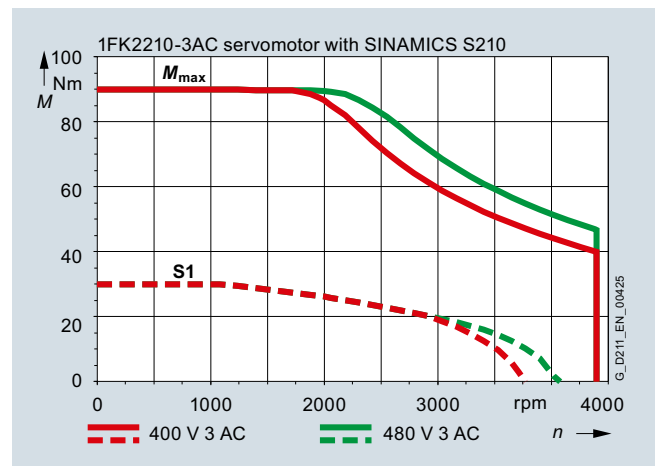
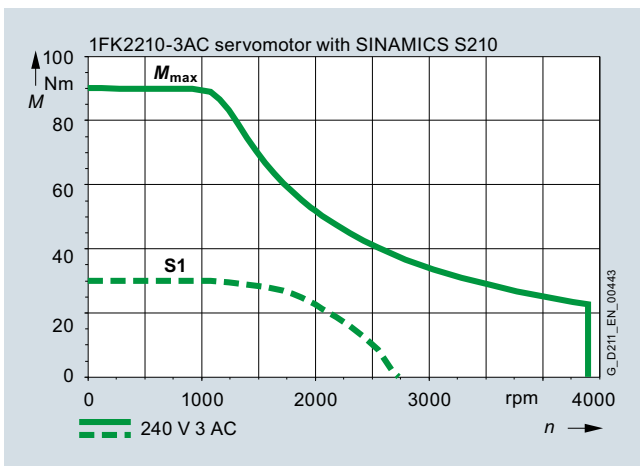
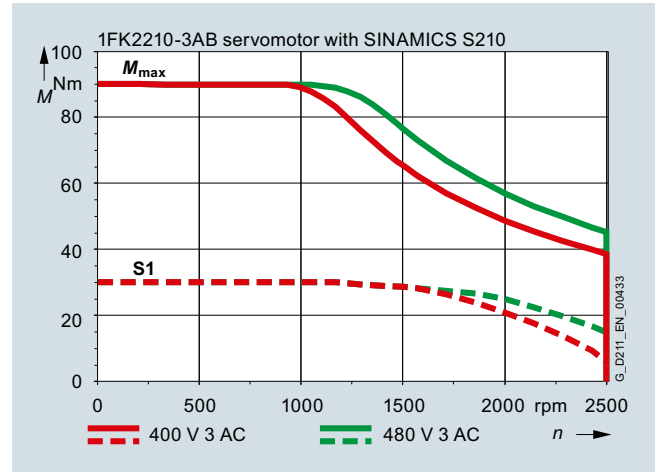
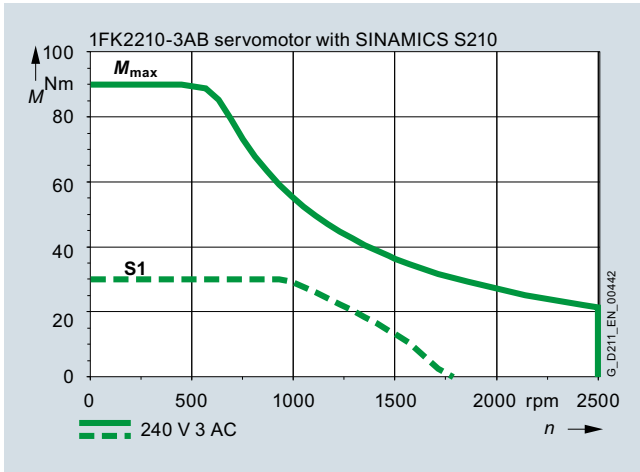

# SIMOTICS S-1FK2 servomotors

## SIMOTICS S-1FK2 servomotors for SINAMICS S210

### Technical specifications

Speed/torque characteristics (continued)

Compact (continued)

3

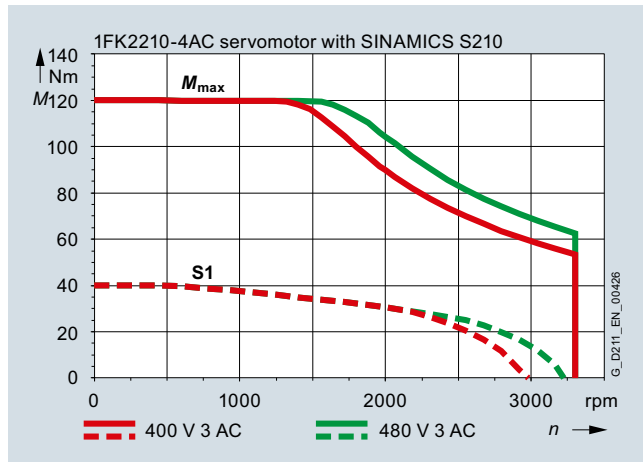
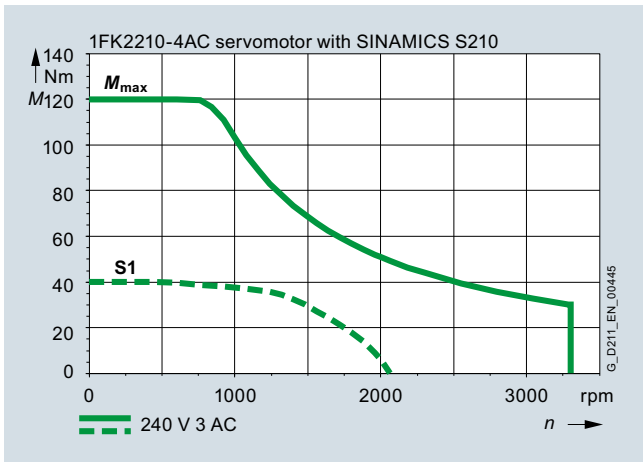
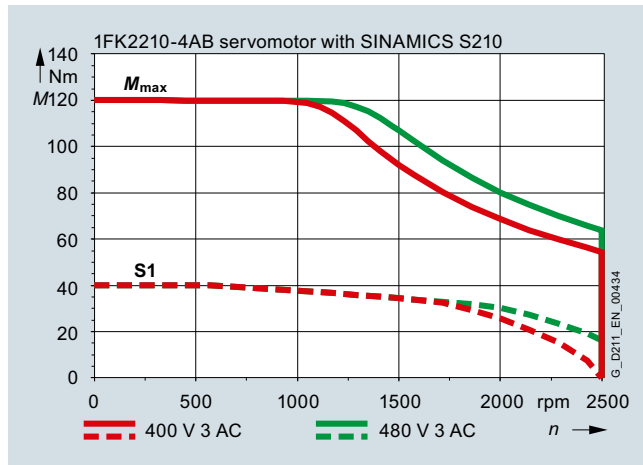
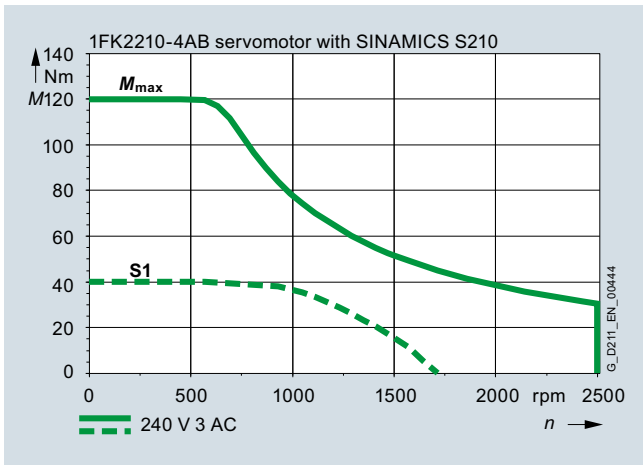



**MOTION-CONNECT connection systems****4/2 MOTION-CONNECT connection systems**

- 4/2 Overview
- 4/2 Benefits
- 4/2 Application
- 4/2 Function
- 4/3 Characteristic curves
- 4/4 More information

**4/5 One Cable Connection (OCC) technology for SINAMICS S210**

- 4/5 Overview
- 4/5 Technical specifications
- 4/6 Selection and ordering data
- 4/8 More information

Detailed technical information on the SINAMICS S210 servo drive system is available on the Internet at:  
[www.siemens.com/sinamics-s210/documentation](http://www.siemens.com/sinamics-s210/documentation)

In addition, the Drive Technology Configurator (DT Configurator) can be used on the Internet at the following address:  
[www.siemens.com/dt-configurator](http://www.siemens.com/dt-configurator)

## MOTION-CONNECT connection systems

### MOTION-CONNECT connection systems

#### Overview

MOTION-CONNECT cables are suitable for use with many different types of machine tools and production machinery.

The following variants of MOTION-CONNECT cable are available as fully-assembled power and signal cables or sold by the meter:

- **MOTION-CONNECT 500**
  - Cost-effective solution for predominantly fixed installation
  - Suitable for low mechanical loading
  - Tested for traversing paths up to 5 m (16.4 ft)
- **MOTION-CONNECT 800PLUS**
  - Meets requirements for use in cable carriers
  - Suitable for high mechanical loading
  - Oil resistance
  - Tested for traversing paths of up to 50 m (164 ft)

#### Benefits

Pre-assembled MOTION-CONNECT cables provide high quality and impeccable system-tested functionality.

#### SPEED-CONNECT

Connectors with SPEED-CONNECT quick-release locks enable fast, stable and reliable connections. All that is required to attain stable interlocking and a secure connection is less than a quarter turn of the lock nut of the connector. Tools are not required.

Cables with SPEED-CONNECT connectors supplement the previous offering of MOTION-CONNECT cables with full-thread connectors.

#### Application

MOTION-CONNECT cables are intended for use in machines. They are not suitable for building technology applications or outdoor installation.

MOTION-CONNECT cables have been tested in a cable carrier with horizontal traversing path and have also been designed for this type of application. They are not self-supporting.

The pre-assembled cables can be ordered in length units of 10 cm (3.94 in) and can be extended, if necessary.

When cable lengths (basic cables and extensions) are determined for the systems and applications described in this catalog, the technically permissible maximum cable lengths (e.g. 25 m (82 ft)) specified in the catalog must be observed. Malfunctions can occur if longer cables are used. Siemens assumes no liability for correct transmission of signals or power in this case.

#### Function

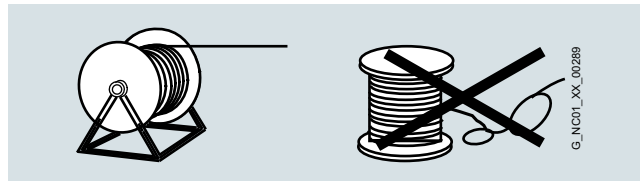

The cables must be removed from the drum without twisting, i.e., the cables must be unwound and must never be lifted over the drum flange in loops.

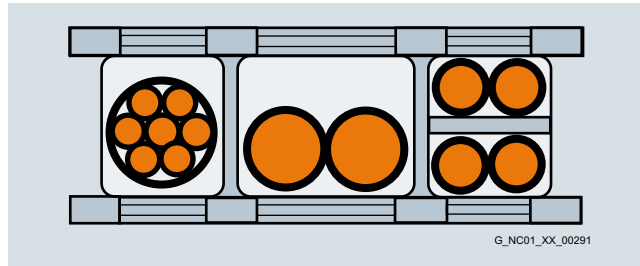

To maximize the service life of the cable carrier and cables, cables in the carrier made from different materials must be separated by spacers in the cable carrier. The spacers must be filled evenly to ensure that the position of the cables does not change during operation. The cables should be distributed as symmetrically as possible according to their weights and dimensions. Cables with very different outer diameters should also be separated by spacers.

When inserting pre-assembled cables into the cable carrier, do not pull at the connector, as this may damage the strain relief or cable clamping.

The cables must not be fixed in the cable carrier. They must be freely movable.

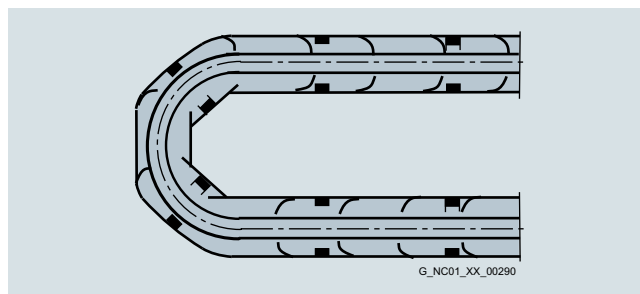

The cables must be able to be moved without applying force in particular in the bending radii of the carrier. The specified minimum bending radius must be adhered to.

## Function

The cable fixings must be attached at both ends at an appropriate distance away from the end points of the moving parts in a dead zone.

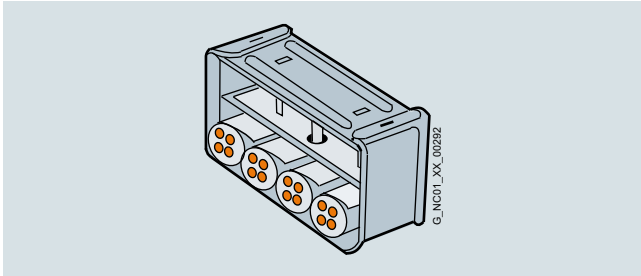

MOTION-CONNECT cables are tested in a cable carrier. The cables are attached at one end by means of strain relief to the moving ends of the cable carrier. Strain relief is applied over a wide area of the cable jacket surface without crimping the cable.

Cables must be installed in accordance with the instructions supplied by the cable carrier manufacturer.

### Note:

If, for example, pre-assembled cables are installed in a cable carrier in such a way that the connector would inhibit assembly, pre-assembled cables without assembled connector can also be supplied (power and signal cables<sup>1)</sup>). Depending on the version, the contacts of the cables are crimped and the connector is supplied separately. After installing the cables, the customer assembles the connector.

In case of vibration load and with horizontal or vertical cable entries, we recommend that the cable is additionally fixed if between the cable strain relief on the cable carrier and the terminal at the motor part of the cable is hanging loose or is not routed. To prevent machine vibrations being transmitted to the connectors, the cable should be fixed at the moving part where the motor is mounted.

## Characteristic curves

### Characteristic curve for MOTION-CONNECT 800PLUS

The blue area beneath the characteristic curve represents the potential range of use for the cables. The characteristic curve represents the tested operating points.

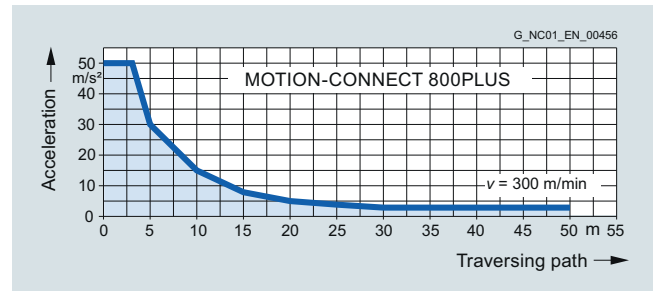

Permissible acceleration for MOTION-CONNECT 800PLUS signal and power cables up to 16 mm<sup>2</sup>

<sup>1)</sup> Not for DRIVE-CLiQ signal cables.

## MOTION-CONNECT connection systems

### MOTION-CONNECT connection systems

#### More information

##### Current carrying capacity for power and signal cables

The current carrying capacity of PVC/PUR-insulated copper cables is specified in the table for installation types B1, B2, C, and E under continuous operating conditions with reference to

an ambient air temperature of 40 °C (104 °F). For other ambient temperatures, the values must be corrected by the derating factors from the table.

Cross-section mm <sup>2</sup>	Current carrying capacity rms AC 50/60 Hz or DC in amps for installation type			
	B1 Single-core cables in conduits or installation ducts	B2 Multi-core cables in conduits or installation ducts	C Multi-core cables, vertically or horizontally on walls/open, without conduits and installation ducts/ with contact	E Multi-core cables, horizontally or vertically on perforated cable racks/open, without conduits and installation ducts/ with contact
<b>Electronics <sup>1)</sup></b>				
0.2	–	4.3	4.4	4.4
0.5	–	7.5	7.5	7.8
0.75	–	9	9.5	10
<b>Power <sup>2)</sup></b>				
0.38	6.2	6.1	7.1	7.4
0.75	8.6	8.5	9.8	10.4
1	10.3	10.1	11.7	12.4
1.5	13.5	13.1	15.2	16.1
2.5	18.3	17.4	21	22
4	24	23	28	30
6	31	30	36	37
10	44	40	50	52
16	59	54	66	70

##### Derating factors for power and signal cables

Ambient air temperature °C (°F)	Derating factor acc. to EN 60204-1, Table D.1
30 (86)	1.15
35 (95)	1.08
40 (104)	1
45 (113)	0.91
50 (122)	0.82
55 (131)	0.71
60 (140)	0.58

<sup>1)</sup> One control circuit pair.

<sup>2)</sup> One symmetrically loaded three-phase AC cable.

## Overview

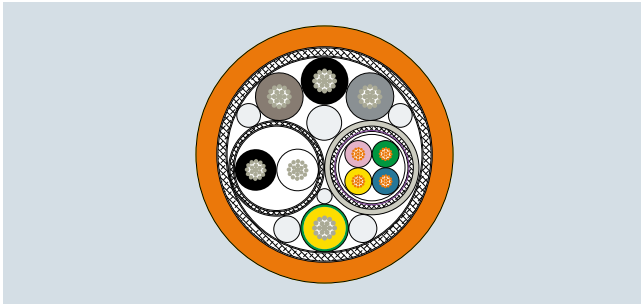

Motor and converter are simply connected to one another by one cable instead of the usual two or three cables. With this One Cable Technology, energy supply, encoder signals and braking signal are brought together in a single cable.

This results in the following advantages:

- Time-saving by laying only one cable
- Smaller installation space and space requirement in cable collars
- Only one cable has to be cleaned. This is advantageous, e.g. in the pharmaceutical industry and where higher requirements are placed upon hygiene
- Can be ordered to the decimeter
- Compact connection system
- Rotatable connectors on the motor side
- Motor with very low interfering contour for restricted installation space
- Bending radius optimized to  $2.5 \times$  cable diameter static or  $4 \times$  cable diameter dynamic for MOTION-CONNECT 800PLUS

## Technical specifications



MOTION-CONNECT 500	6FX5002-8QN04-1...	6FX5002-8QN08-1...	6FX5002-8QN11-1...	6FX5002-8QN21-1...
<b>Connector</b>				
• Converter side	Siemens IX	Siemens IX	Siemens IX	Siemens IX
• Motor side	M12 (SPEED-CONNECT)	M17 (SPEED-CONNECT)	M23 (SPEED-CONNECT)	M23 (SPEED-CONNECT)
<b>Number of cores</b>	10	10	10	10
<b>Cross-section</b>	0.38 mm <sup>2</sup>	0.75 mm <sup>2</sup>	1.5 mm <sup>2</sup>	2.5 mm <sup>2</sup>
<b>Cable length, max.</b>	50 m (164 ft)	50 m (164 ft)	50 m (164 ft)	50 m (164 ft)
<b>Cable structure</b>	4G0.38+1Q0.2+1P0.38	4G0.75+1Q0.2+1P0.5	4G1.5+1Q0.2+1P1.5	4G2.5+1Q0.2+1P1.5
<b>Max. number of bends</b>	100000	100000	100000	100000
<b>Number of disconnection points, max.</b>	3 in 50 m (3 in 164 ft)	3 in 50 m (3 in 164 ft)	3 in 50 m (3 in 164 ft)	3 in 50 m (3 in 164 ft)
<b>Degree of protection</b>				
• Converter side	IP20	IP20	IP20	IP20
• Motor side	IP65	IP65	IP65	IP65
<b>Certificates of suitability</b>	RoHS, cURus, CE	RoHS, cURus, CE	RoHS, cURus, CE	RoHS, cURus, CE
<b>Suitable for SIMOTICS S-1FK2 servomotor</b>	1FK2102 and 1FK2.03	1FK2.04 and 1FK2.05	1FK2.06, 1FK2.08 and 1FK2.10	1FK2.06, 1FK2.08 and 1FK2.10
<b>MOTION-CONNECT 800PLUS</b>	6FX8002-8QN04-1...	6FX8002-8QN08-1...	6FX8002-8QN11-1...	6FX8002-8QN21-1...
<b>Connector</b>				
• Converter side	Siemens IX	Siemens IX	Siemens IX	Siemens IX
• Motor side	M12 (SPEED-CONNECT)	M17 (SPEED-CONNECT)	M23 (SPEED-CONNECT)	M23 (SPEED-CONNECT)
<b>Number of cores</b>	10	10	10	10
<b>Cross-section</b>	0.38 mm <sup>2</sup>	0.75 mm <sup>2</sup>	1.5 mm <sup>2</sup>	2.5 mm <sup>2</sup>
<b>Cable length, max.</b>	50 m (164 ft)	50 m (164 ft)	50 m (164 ft)	50 m (164 ft)
<b>Cable structure</b>	4G0.38+1Q0.2+1P0.38	4G0.75+1Q0.2+1P0.5	4G1.5+1Q0.2+1P1.5	4G2.5+1Q0.2+1P1.5
<b>Max. number of bends</b>	10 million	10 million	10 million	10 million
<b>Number of disconnection points, max.</b>	3 in 50 m (3 in 164 ft)	3 in 50 m (3 in 164 ft)	3 in 50 m (3 in 164 ft)	3 in 50 m (3 in 164 ft)
<b>Degree of protection</b>				
• Converter side	IP20	IP20	IP20	IP20
• Motor side	IP65	IP65	IP65	IP65
<b>Certificates of suitability</b>	RoHS, cURus, CE	RoHS, cURus, CE	RoHS, cURus, CE	RoHS, cURus, CE
<b>Suitable for SIMOTICS S-1FK2 servomotor</b>	1FK2102 and 1FK2.03	1FK2.04 and 1FK2.05	1FK2.06, 1FK2.08 and 1FK2.10	1FK2.06, 1FK2.08 and 1FK2.10

# MOTION-CONNECT connection systems

## One Cable Connection (OCC) technology for SINAMICS S210

### Selection and ordering data

#### Motor connection cable

Design	Description	Connector size	Cross-section mm <sup>2</sup>	$D_{max}$ mm (in)	$r_{static}$ mm (in)	$r_{dynamic}$ mm (in)	For motor	Article No.
	<b>Pre-assembled OCC motor connection cable MOTION-CONNECT 500 for predominantly fixed routing</b> With SPEED-CONNECT connector (shield connection clamp included in the scope of delivery)	M12	0.38	9.7 (0.38)	23.5 (0.93)	195 (7.68)	1FK2102, 1FK2.03	6FX5002-8QN04-1 ■■■■ (Length code see table)
		M17	0.75	10.5 (0.41)	25.5 (1.00)	195 (7.68)	1FK2.04, 1FK2.05	6FX5002-8QN08-1 ■■■■
		M23	1.5	12.7 (0.50)	30.7 (1.21)	195 (7.68)	1FK2.06, 1FK2.08, 1FK2.10	6FX5002-8QN11-1 ■■■■
		M23	2.5 <sup>2)</sup>	13.7 (0.54)	30.7 (1.21)	195 (7.68)	1FK2.10	6FX5002-8QN21-1 ■■■■
	<b>Pre-assembled OCC motor connection cable MOTION-CONNECT 800PLUS for use with cable carriers</b> With SPEED-CONNECT connector (shield connection clamp included in the scope of delivery)	M12	0.38	9.7 (0.38)	28.2 (1.11)	38 (1.50)	1FK2102, 1FK2.03	6FX8002-8QN04-1 ■■■■
		M17	0.75	10.5 (0.41)	30.6 (1.20)	38 (1.50)	1FK2.04, 1FK2.05	6FX8002-8QN08-1 ■■■■
		M23	1.5	12.7 (0.50)	36.9 (1.45)	92.2 (3.63)	1FK2.06, 1FK2.08, 1FK2.10	6FX8002-8QN11-1 ■■■■
		M23	2.5 <sup>2)</sup>	13.7 (0.54)	39.9 (1.57)	99.7 (3.93)	1FK2.10	6FX8002-8QN21-1 ■■■■
	<b>OCC motor connection cable MOTION-CONNECT 500 for predominantly fixed routing</b> With SPEED-CONNECT connector and SIEMENS IX signal connector for the converter end supplied with the cable (shield connection clamp included in the scope of delivery) <sup>1)</sup>	M12	0.38	9.7 (0.38)	23.5 (0.93)	195 (7.68)	1FK2102, 1FK2.03	6FX5012-8QN04-1 ■■■■
		M17	0.75	10.5 (0.41)	25.5 (1.00)	195 (7.68)	1FK2.04, 1FK2.05	6FX5012-8QN08-1 ■■■■
		M23	1.5	12.7 (0.50)	30.7 (1.21)	195 (7.68)	1FK2.06, 1FK2.08, 1FK2.10	6FX5012-8QN11-1 ■■■■
		M23	2.5 <sup>2)</sup>	13.7 (0.54)	30.7 (1.21)	195 (7.68)	1FK2.10	6FX5012-8QN21-1 ■■■■
	<b>OCC motor connection cable MOTION-CONNECT 800PLUS for use with cable carriers</b> With SPEED-CONNECT connector and SIEMENS IX signal connector for the converter end supplied with the cable (shield connection clamp included in the scope of delivery) <sup>1)</sup>	M12	0.38	9.7 (0.38)	28.2 (1.11)	38 (1.50)	1FK2102, 1FK2.03	6FX8012-8QN04-1 ■■■■
		M17	0.75	10.5 (0.41)	30.6 (1.20)	38 (1.50)	1FK2.04, 1FK2.05	6FX8012-8QN08-1 ■■■■
		M23	1.5	12.7 (0.50)	36.9 (1.45)	92.2 (3.63)	1FK2.06, 1FK2.08, 1FK2.10	6FX8012-8QN11-1 ■■■■
		M23	2.5 <sup>2)</sup>	13.7 (0.54)	39.9 (1.57)	99.7 (3.93)	1FK2.10	6FX8012-8QN21-1 ■■■■

#### Extension cable

Design	Description	Connector size	Cross-section mm <sup>2</sup>	$D_{max}$ mm (in)	$r_{static}$ mm (in)	$r_{dynamic}$ mm (in)	For motor	Article No.
	<b>Pre-assembled OCC extension cable MOTION-CONNECT 500 for predominantly fixed routing</b> with SPEED-CONNECT connectors	M12	0.38	9.7 (0.38)	23.5 (0.93)	195 (7.68)	1FK2102, 1FK2.03	6FX5002-8QE04-1 ■■■■ (Length code see table)
		M17	0.75	10.5 (0.41)	25.5 (1.00)	195 (7.68)	1FK2.04, 1FK2.05	6FX5002-8QE08-1 ■■■■
		M23	1.5	12.7 (0.50)	30.7 (1.21)	195 (7.68)	1FK2.06, 1FK2.08, 1FK2.10	6FX5002-8QE11-1 ■■■■
		M23	2.5 <sup>2)</sup>	13.7 (0.54)	30.7 (1.21)	195 (7.68)	1FK2.10	6FX5002-8QE21-1 ■■■■
	<b>Pre-assembled OCC extension cable MOTION-CONNECT 800PLUS for use with cable carriers</b> with SPEED-CONNECT connectors	M12	0.38	9.7 (0.38)	28.2 (1.11)	38 (1.50)	1FK2102, 1FK2.03	6FX8002-8QE04-1 ■■■■
		M17	0.75	10.5 (0.41)	30.6 (1.20)	38 (1.50)	1FK2.04, 1FK2.05	6FX8002-8QE08-1 ■■■■
		M23	1.5	12.7 (0.50)	36.9 (1.45)	92.2 (3.63)	1FK2.06, 1FK2.08, 1FK2.10	6FX8002-8QE11-1 ■■■■
		M23	2.5 <sup>2)</sup>	13.7 (0.54)	39.9 (1.57)	99.7 (3.93)	1FK2.10	6FX8002-8QE21-1 ■■■■
	<b>Pre-assembled OCC extension cable MOTION-CONNECT 500 for predominantly fixed routing</b> with SPEED-CONNECT connectors (male contacts fixed at the converter end, insulators and connector housing supplied with cable) <sup>1)</sup>	M12	0.38	9.7 (0.38)	23.5 (0.93)	195 (7.68)	1FK2102, 1FK2.03	6FX5012-8QE04-1 ■■■■
		M17	0.75	10.5 (0.41)	25.5 (1.00)	195 (7.68)	1FK2.04, 1FK2.05	6FX5012-8QE08-1 ■■■■
		M23	1.5	12.7 (0.50)	30.7 (1.21)	195 (7.68)	1FK2.06, 1FK2.08, 1FK2.10	6FX5012-8QE11-1 ■■■■
		M23	2.5 <sup>2)</sup>	13.7 (0.54)	30.7 (1.21)	195 (7.68)	1FK2.10	6FX5012-8QE21-1 ■■■■
<b>Pre-assembled OCC extension cable MOTION-CONNECT 800PLUS for use with cable carriers</b> with SPEED-CONNECT connectors (male contacts fixed at the converter end, insulators and connector housing supplied with cable) <sup>1)</sup>	M12	0.38	9.7 (0.38)	28.2 (1.11)	38 (1.50)	1FK2102, 1FK2.03	6FX8012-8QE04-1 ■■■■	
	M17	0.75	10.5 (0.41)	30.6 (1.20)	38 (1.50)	1FK2.04, 1FK2.05	6FX8012-8QE08-1 ■■■■	
	M23	1.5	12.7 (0.50)	36.9 (1.45)	92.2 (3.63)	1FK2.06, 1FK2.08, 1FK2.10	6FX8012-8QE11-1 ■■■■	
	M23	2.5 <sup>2)</sup>	13.7 (0.54)	39.9 (1.57)	99.7 (3.93)	1FK2.10	6FX8012-8QE21-1 ■■■■	







<sup>1)</sup> Available soon.

<sup>2)</sup> For increased requirement regarding routing type and ambient temperature.  
See tables on page 4/4.

## Selection and ordering data

## Accessories

## OCC components for customer assembly

Design	Description	Cross-section mm <sup>2</sup>	For motor	Article No. (Length code see table)
	<b>Sold by the meter, OCC line MOTION-CONNECT 500</b> For the self-assembly of motor connection or extension cables MOTION-CONNECT 500 predominantly for fixed routing (see table for length codes) <sup>1)</sup>	0.38	1FK2102, 1FK2.03	<b>6FX5008-1BE04-1</b> ■■■■
		0.75	1FK2.04, 1FK2.05	<b>6FX5008-1BE08-1</b> ■■■■
		1.5	1FK2.06, 1FK2.08, 1FK2.10	<b>6FX5008-1BE11-1</b> ■■■■
		2.5 <sup>2)</sup>	1FK2.06, 1FK2.08, 1FK2.10	<b>6FX5008-1BE21-1</b> ■■■■
	<b>Sold by the meter, OCC line MOTION-CONNECT 800PLUS</b> For the self-assembly of motor connection or extension cables MOTION-CONNECT 800PLUS for use with cable carriers (see table for length codes) <sup>1)</sup>	0.38	1FK2102, 1FK2.03	<b>6FX8008-1BE04-1</b> ■■■■
		0.75	1FK2.04, 1FK2.05	<b>6FX8008-1BE08-1</b> ■■■■
		1.5	1FK2.06, 1FK2.08, 1FK2.10	<b>6FX8008-1BE11-1</b> ■■■■
		2.5 <sup>2)</sup>	1FK2.06, 1FK2.08, 1FK2.10	<b>6FX8008-1BE21-1</b> ■■■■
	<b>Motor-side M12 SPEED-CONNECT connector</b> 10-pole, including all socket contacts <sup>1)</sup>	0.38	1FK2102, 1FK2.03	<b>6FX2003-0LU64</b>
		<b>Motor-side M17 SPEED-CONNECT connector</b> 10-pole, including all socket contacts <sup>1)</sup>	0.75	1FK2.04, 1FK2.05
<b>Motor-side M23 SPEED-CONNECT connector</b> 10-pole, including all socket contacts <sup>1)</sup>		1.5 and 2.5	1FK2.06, 1FK2.08, 1FK2.10	<b>6FX2003-0LU34</b>
	<b>M12 SPEED-CONNECT connector with external thread for extension cable</b> 10-pole, including all pin contacts <sup>1)</sup>	0.38	1FK2102, 1FK2.03	<b>6FX2003-0LA64</b>
		<b>M17 SPEED-CONNECT connector with external thread for extension cable</b> 10-pole, including all pin contacts <sup>1)</sup>	0.75	1FK2.04, 1FK2.05
<b>M23 SPEED-CONNECT connector with external thread for extension cable</b> 10-pole, including all pin contacts <sup>1)</sup>		1.5 and 2.5	1FK2.06, 1FK2.08, 1FK2.10	<b>6FX2003-0LA34</b>
	<b>Converter-side Siemens IX signal connector</b> Device version in insulation displacement technology for field assembly <sup>1)</sup>	–	–	<b>6FX2003-0DE01</b>
	<b>Shield clamp</b> For attaching the connection cables to the shield plate of the converter (packing unit 10 items) • For pre-assembled cables with M12 and M17 connectors • For pre-assembled cables with M23 connectors	–	–	<b>6FX2003-7EX10</b>
		–	–	<b>6FX2003-7EX11</b>

<sup>1)</sup> Available soon.<sup>2)</sup> For increased requirement regarding routing type and ambient temperature. See tables on page 4/4.

## MOTION-CONNECT connection systems

### One Cable Connection (OCC) technology for SINAMICS S210

#### Selection and ordering data (continued)

##### Control cabinet bushing

Design	Description	Article No.
	<b>Mounting flange</b> For cabinet bushing <ul style="list-style-type: none"> <li>• For connector size M12</li> <li>• For connector size M17</li> <li>• For connector size M23</li> </ul>	<b>6FX2003-7JX00</b> <b>6FX2003-7HX00</b> <b>6FX2003-7BX00</b>

##### Length code (max. 50 m (164 ft))

Description	Article No. supplement
<b>MOTION-CONNECT cable</b>	<b>6FX . 0 . 2-8Q . 0 . -1</b> ■ ■ ■ ■
0 m (0 ft)	<b>A</b>
10 m (32.8 ft)	<b>B</b>
20 m (65.6 ft)	<b>C</b>
30 m (98.4 ft)	<b>D</b>
40 m (131 ft)	<b>E</b>
50 m (164 ft)	<b>F</b>
0 m (0 ft)	<b>A</b>
1 m (3.28 ft)	<b>B</b>
2 m (6.56 ft)	<b>C</b>
3 m (9.84 ft)	<b>D</b>
4 m (13.1 ft)	<b>E</b>
5 m (16.4 ft)	<b>F</b>
6 m (19.7 ft)	<b>G</b>
7 m (23.0 ft)	<b>H</b>
8 m (26.2 ft)	<b>J</b>
9 m (29.5 ft)	<b>K</b>
0 m (0 ft)	<b>0</b>
0.1 m (0.33 ft)	<b>1</b>
0.2 m (0.66 ft)	<b>2</b>
0.3 m (0.98 ft)	<b>3</b>
0.4 m (1.31 ft)	<b>4</b>
0.5 m (1.64 ft)	<b>5</b>
0.6 m (1.97 ft)	<b>6</b>
0.7 m (2.30 ft)	<b>7</b>
0.8 m (2.62 ft)	<b>8</b>

#### More information

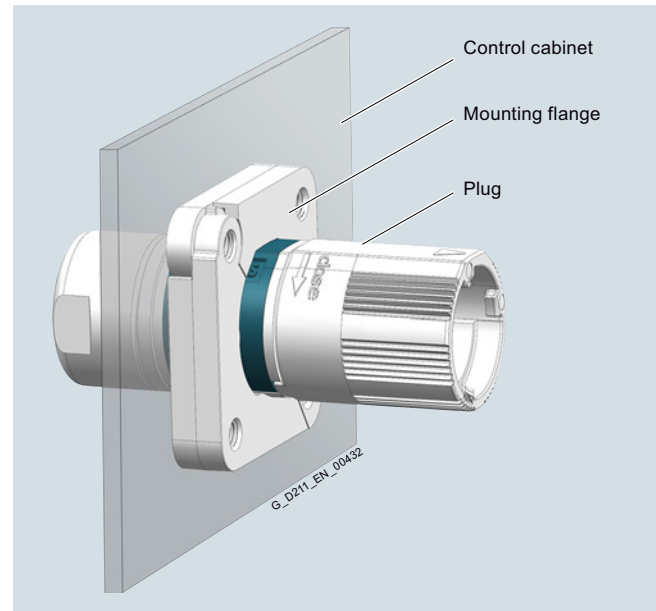

Arrangement of mounting flange and plug in a control cabinet panel

More information, particularly on grounding, is available in the technical documentation on the Internet at:  
[www.siemens.com/sinamics-s210/documentation](http://www.siemens.com/sinamics-s210/documentation)



## Engineering tools

**Security information**

Siemens provides products and solutions with industrial security functions that support the secure operation of plants, systems, machines and networks.

In order to protect plants, systems, machines and networks against cyber threats, it is necessary to implement – and continuously maintain – a holistic, state-of-the-art industrial security concept. Siemens' products and solutions constitute one element of such a concept. Customers are responsible for preventing unauthorized access to their plants, systems, machines and networks. Such systems, machines and components should only be connected to an enterprise network or the internet if and to the extent such a connection is necessary and only when appropriate security measures (e.g. firewalls and/or network segmentation) are in place.

For additional information on industrial security measures that may be implemented, please visit

<https://www.siemens.com/industrialsecurity>

Siemens' products and solutions undergo continuous development to make them more secure. Siemens strongly recommends that product updates are applied as soon as they are available and that the latest product versions are used. Use of product versions that are no longer supported, and failure to apply the latest updates may increase customer's exposure to cyber threats.

To stay informed about product updates, subscribe to the Siemens Industrial Security RSS Feed under

<https://www.siemens.com/industrialsecurity>

5/2	<b>Drive Technology Configurator</b>
5/3	<b>TIA Selection Tool</b>
5/4	<b>SINAMICS Web server for SINAMICS S210</b>
5/5	<b>SINAMICS Startdrive commissioning tool</b>

## Engineering tools

### Drive Technology Configurator

#### Overview

The Drive Technology Configurator (DT Configurator) helps you to configure the optimum drive technology products for your application – starting with gear units, motors, converters as well as the associated options and components and ending with controllers, software licenses and connection systems. Whether with little or detailed knowledge of products: preselected product groups, deliberate navigation through selection menus and direct product selection through entry of the article number support quick, efficient and convenient configuration.

In addition, comprehensive documentation comprising technical data sheets, 2D dimensional drawings/3D CAD models, operating instructions, certificates, etc. can be selected in the DT Configurator. Immediate ordering is possible by simply transferring a parts list to the shopping cart of the Industry Mall.

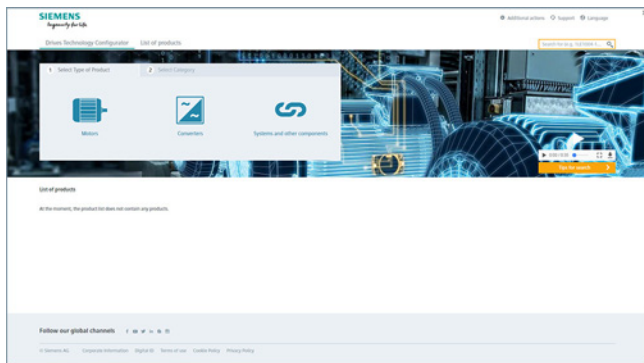

#### *Drive Technology Configurator for efficient drive configuration with the following functions*

- Quick and easy configuration of drive products and associated components – gear units, motors, converters, controllers, connection systems
- Configuration of drive systems for pump, fan and compressor applications from 1 kW to 2.6 MW
- Retrievable documentation for configured products and components, such as
  - Data sheets in up to 9 languages in PDF or RTF format
  - 2D dimensional drawings/3D CAD models in various formats
  - Terminal box drawing and terminal connection diagram
  - Operating instructions
  - Certificates
  - Start-up calculation for SIMOTICS motors
  - EPLAN macros
- Support with retrofitting in conjunction with Spares On Web [www.siemens.com/sow](http://www.siemens.com/sow)
- Ability to order products directly through the Siemens Industry Mall

#### Access to the Drive Technology Configurator

The Drive Technology Configurator can be called up without registration and without a login:

[www.siemens.com/dt-configurator](http://www.siemens.com/dt-configurator)

#### More information

[Online access to the Drive Technology Configurator](#)

More information about the Drive Technology Configurator is available on the Internet at [www.siemens.com/dtconfigurator](http://www.siemens.com/dtconfigurator)

[Offline access to the Drive Technology Configurator in the Interactive Catalog CA 01](#)

In addition, the Drive Technology Configurator is also included in the Interactive Catalog CA 01 – the offline version of the Siemens Industry Mall.

The Interactive Catalog CA 01 in German, English, French and Spanish is available for downloading from the Internet: [www.siemens.com/automation/ca01](http://www.siemens.com/automation/ca01)

## Overview

### Selection guide and configurator for automation technology

Error-free configuration without expert knowledge through intelligent configurators and selection wizards. Desktop and cloud versions enable cross-team collaboration with maximum flexibility.

There are two versions of the TIA Selection Tool:

- One for downloading and execution on Windows PCs (from Microsoft Windows 7)
- One for running from the cloud, which is launched from mobile devices directly in the browser (we recommend Safari, Chrome and Firefox)

Projects stored in the cloud can be edited with both tools. This makes it possible to work on-the-go using a tablet, at home on a PC – and vice versa, or together with colleagues and customers.

In order to use the full functionality, we recommended setting up a Siemens Industry Mall account for both cases. This gives you access to prices and enables you to save your projects to our cloud.

You can find additional information about the TIA Selection Tool at:

[www.siemens.com/tia-selection-tool](http://www.siemens.com/tia-selection-tool)

## Engineering tools

### SINAMICS Web server for SINAMICS S210

#### Overview

*Web server for efficient commissioning, diagnostics and maintenance – available anywhere, anytime*

Thanks to the web server, the SINAMICS S210 drive system offers efficient commissioning, diagnostics and maintenance options. The web server provides access to a multi-faceted range of new options for parameter assignment, drive diagnostics and remote maintenance for any networked PC with a web browser or for tablets and smartphones (via a separate WLAN access point), including:

- Simple and fast commissioning
- Drive traversing via the control panel
- Downloading/uploading a configuration
- Providing a status overview of the drive
- Evaluating warnings and fault messages
- Monitoring and adapting parameter setting

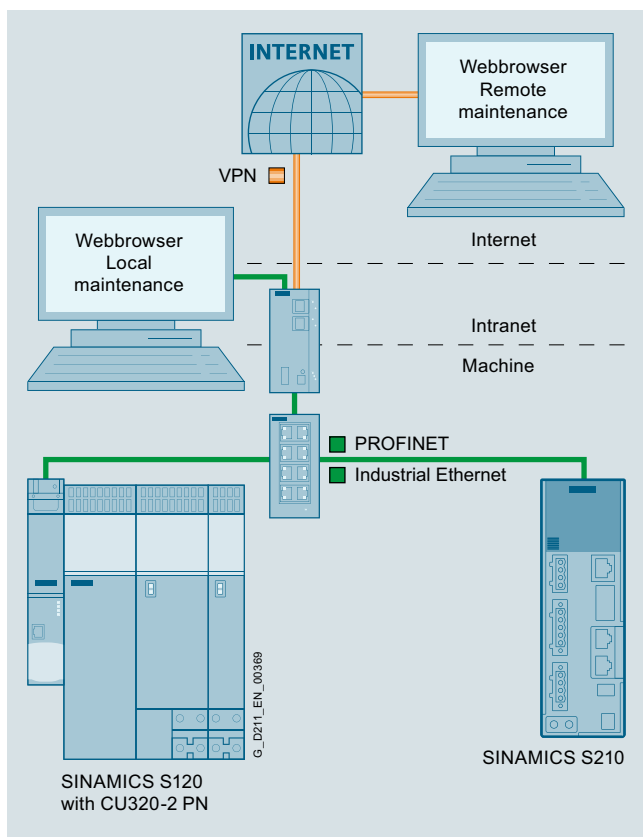

Integration of the SINAMICS web server as shown by the example of SINAMICS S120, SINAMICS S210 and PROFINET communication

The SINAMICS web server is available as of SINAMICS S210 firmware V5.1.

#### Benefits

##### Simple and fast commissioning

- No installation of additional commissioning software
- Simple controller optimization with One Button Tuning
- Easy parameterization of Safety Integrated Functions
- Standard pages for limit values and settings
- Comprehensive fault diagnosis
- Firmware update

##### Shorter machine downtimes

- Efficient diagnostics and maintenance

##### Direct language selection

- English, French, German, Italian, Spanish, Chinese Simplified

##### Accessibility

- Via all LAN or PROFINET interfaces
- Tablet and smartphone access via WLAN with separate access point

##### Two users with different rights profiles

- e.g. for operators and service personnel

##### Diagnostic functions

- Quick overview of the current configuration and the state of the drive
- Understandable diagnostic information and messages, including the causes of issues and possible remedies, are displayed in plain text in multiple languages

##### Freely configurable parameter lists

- Monitoring parameters for diagnostic purposes, for example for operating personnel
- Adjustment of the parameter lists using filters, parameter groups and the configuration of personal lists

##### Access security

- Protection against unauthorized access to the drive information

#### Application

The web server is ideal for applications in which special commissioning software or version dependencies are not desired. Easy commissioning, diagnostics and maintenance are possible both locally and remotely, provided appropriate security measures are applied.

## Overview

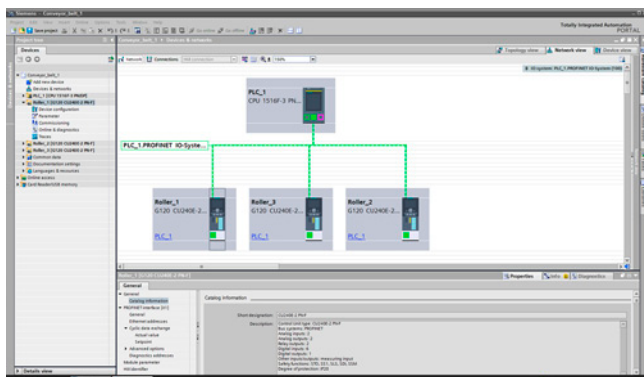

SINAMICS Startdrive is a tool for configuring, commissioning, and diagnosing the SINAMICS converter family and is integrated into the TIA Portal.

The SINAMICS Startdrive commissioning tool has been optimized with regard to user friendliness and consistent use of the TIA Portal benefits of a common working environment for PLC, HMI and drives.

### Performance features

Efficient commissioning with easy configuration and powerful tools:

- High degree of usability thanks to task-based navigation through the engineering workflow
  - Hardware configuration
  - Parameterization
  - Commissioning
  - Diagnostics
- Time-saving and guided step-by-step commissioning with maximum flexibility
- User-friendly graphic function view for all drive functions
- List of drive parameters structured according to functions
- Easy integration of SIMOTICS motors
- Integrated control panel for direct operation of the converter from the TIA Portal
- Powerful realtime trace for commissioning and drive diagnostics
- Intuitive and efficient drive diagnostics through automatic display of messages
- Context-sensitive online help, e.g. for drive messages
- Integrated detailed drive diagnostic functions
  - Control/status words
  - Parameter status
  - Operating conditions
  - Communication states
- Simple configuration for drive-end Safety Integrated
- Drive-internal basic positioning function (provided it is available in the drive)
- Support of One Button Tuning for the simplest optimization of the drive (provided it is available in the drive)
- Integrated safety acceptance test to facilitate the required documentation

## Integration

### Integration of the SINAMICS converter family with SIMATIC in the TIA Portal

The software packages based on the TIA Portal are harmonized with each other and offer important benefits. The TIA Portal enables simple integration of SINAMICS converters in your automation solution:

- Reduction in training costs thanks to cross-tool uniformity of the operator inputs
- Device configuration and network connection of the converters in the TIA Portal-wide configuration/network editor
- Device access to the drives via the PLC across network boundaries (dataset routing)
- Automatic frame comparison between converters and SIMATIC S7 PLC
- Reduction of standstill times through the integration of converter messages in the SIMATIC S7 system diagnostics:
  - The drive messages are part of the SIMATIC S7 system diagnostics without previous configuration effort
  - The drive messages are therefore automatically available as plain text in the TIA Portal, the web server of the SIMATIC S7 PLC and the HMI
- Automatic synchronization of technology-relevant parameters between controller and drive
- Time savings thanks to simple and guided configuration of the drives for operation with SIMATIC S7 Motion Control
- Short familiarization time for SIMATIC STEP 7 users due to common use of editors. Realtime trace and the drive control panel are identical to the editors in STEP 7
- Reuse of the drive configuration and parameterization is possible with the assistance of the TIA Portal library
- Standard TIA Portal functions for converters, e.g. Undo, Redo
- Integration in general TIA Portal operating concepts, e.g. UMAC
- Block library supplied for easy integration of SINAMICS drives into the user programs of the SIMATIC S7-300, S7-400, S7-1200, S7-1500
- Shared project storage for all devices in the project
- Use of the Openness interface for remote control of the TIA Portal with external applications
- Generation of a TIA Portal project by an AML-based import from EPLAN or data import/export from/to EPLAN
  - SINAMICS G120: Control Unit and Power Module supported with EPLAN V2.8
  - SINAMICS S120: Control Unit only
  - SINAMICS S210: Converter only

### Supported frequency converters

The following frequency converters can be configured with SINAMICS Startdrive

- SINAMICS G120
- SINAMICS G120C
- SINAMICS G120D
- SINAMICS G120P
- SINAMICS G110M
- SINAMICS G130
- SINAMICS G150
- SINAMICS S120
- SINAMICS S150
- SINAMICS S210
- SINAMICS medium voltage converters

## Engineering tools

### SINAMICS Startdrive commissioning tool

#### Integration

##### Supported frequency converters (continued)

All of the available Control Units with SINAMICS Firmware V4.4 and later are supported for the SINAMICS G120, G120C, G120D, G120P and G110M devices (including PROFINET, PROFIBUS, Safety Integrated). All combinable Power Modules up to 400 kW can be configured.

Control Units CU320-2 PN and CU310-2 PN from SINAMICS Firmware V4.8 are supported for the SINAMICS S120, G130, G150, S150 devices and for the SINAMICS medium voltage converters.

SINAMICS S210 is supported from firmware V5.2.

##### SINAMICS Startdrive Advanced

- Advanced functions for SINAMICS Startdrive V16: Safety acceptance test for the SINAMICS G120 family, SINAMICS S120 and SINAMICS S210
  - Prompted acceptance test wizard for all drive-based Safety Integrated Functions (Basic and Extended Safety)
  - Automatic and safety function-specific generation of traces to analyze the machine behavior
  - Generation of an acceptance report as Excel file (xlsx format, can also be used with OpenOffice)
  - Available for SINAMICS G110M, G120, G120C, G120D, G120P, S120 and S210
- Also contains all Startdrive Basic functions
- Only a license key is required, no additional installation

##### Installation versions

SINAMICS Startdrive can be installed as an optional package to SIMATIC STEP 7 or as a stand-alone application (without SIMATIC STEP 7).

##### System requirements

The following table shows the recommended hardware and system equipment for the operation of SINAMICS Startdrive.

Hardware	Recommendation
<b>Computer</b>	As of SIMATIC FIELD PG M5 Advanced (or comparable PC)
<b>Processor</b>	Intel Core i5-6440EQ (up to 3.4 GHz)
<b>RAM</b>	16 GB or more (32 GB for large projects)
<b>Hard disk</b>	SSD with at least 50 GB available memory
<b>Screen resolution</b>	15.6" Full HD display (1920 × 1080 or larger)
<b>Operating systems</b>	<ul style="list-style-type: none"> <li><b>Windows 7 (64 bit)</b> <ul style="list-style-type: none"> <li>Windows 7 Professional SP1</li> <li>Windows 7 Enterprise SP1</li> <li>Windows 7 Ultimate SP1</li> </ul> </li> <li><b>Windows 10 (64 bit)</b> <ul style="list-style-type: none"> <li>Windows 10 Professional Version 1703</li> <li>Windows 10 Enterprise Version 1703</li> <li>Windows 10 Enterprise 2016 LTSB</li> <li>Windows 10 IoT Enterprise 2015 LTSB</li> <li>Windows 10 IoT Enterprise 2016 LTSB</li> </ul> </li> <li><b>Windows Server (64 bit)</b> <ul style="list-style-type: none"> <li>Windows Server 2012 R2 StdE (full installation)</li> <li>Windows Server 2016 Standard (full installation)</li> </ul> </li> </ul>

##### Compatibility with other products

- SINAMICS Startdrive V16 operates with STEP 7, WinCC and Scout TIA V16 in one framework
- SINAMICS Startdrive V16 can be installed on the same computer as other versions of SINAMICS Startdrive V12 to V15.1
- SINAMICS Startdrive can be installed on the same computer as SINAMICS MICROMASTER STARTER

##### Supported virtualization platforms

SINAMICS Startdrive can be installed in a virtual machine. For this purpose, one of the following virtualization platforms in the specified version or a newer version can be used:

- VMware vSphere Hypervisor (ESXi) 6.7
- VMware Workstation pro V14.1.x
- VMware Player V14.1.x
- Microsoft Windows Server 2016 Hyper-V

##### Supported security programs

The following security programs have been tested with SINAMICS Startdrive V16:

- Virus scanners:
  - Symantec Endpoint Protection 14
  - Trend Micro OfficeScan Corporate Edition 12.0/XGen
  - McAfee Endpoint Security 10.x
  - Kaspersky Anti-Virus 2018
  - Windows Defender
  - Qihoo 360 "Safe Guard 11.4" + "Virus Scanner 5.0"
- Encryption software:
  - Microsoft BitLocker
- Host-based Intrusion Detection System
  - McAfee Application Control 8.0

#### Selection and ordering data

Description	Article No.
<b>SINAMICS Startdrive Basic V16 commissioning tool</b> Single license and certificate of license English, French, German, Italian, Spanish, Chinese Simplified • On DVD-ROM • Software download incl. license key (email address required for delivery)	<b>6SL3072-4GA02-0XA0</b> <b>6SL3072-4GA02-0XG0</b>
<b>SINAMICS Startdrive Advanced V16 commissioning tool</b> License key (floating license) English, French, German, Italian, Spanish, Chinese Simplified • On DVD-ROM with license key on USB flash drive • Software download incl. license key (email address required for delivery)	<b>6SL3072-4GA02-0XA5</b> <b>6SL3072-4GA02-0XG5</b>
<b>SINAMICS Startdrive Advanced V15/V15.1 upgrade to V16</b> • On DVD-ROM with license key on USB flash drive • Software download incl. license key (email address required for delivery)	<b>6SL3072-4GA02-0XE5</b> <b>6SL3072-4GA02-0XK5</b>
<b>Software Update Service with SINAMICS Startdrive Advanced in the TIA Portal</b> Delivery is performed according to the number of ordered SUS products (e.g. 10 upgrade license keys (Floating License) with 10 DVD-ROMs, 10 USB flash drives, etc.) • On DVD-ROM with upgrade license key on USB flash drive • Software download incl. license key (email address required for delivery)	<b>6SL3072-4AA02-0XL8</b> <b>6SL3072-4AA02-0XY8</b>

#### More information

The SINAMICS Startdrive Basic commissioning tool is available free on the Internet at [www.siemens.com/startdrive](http://www.siemens.com/startdrive)

## Services and documentation

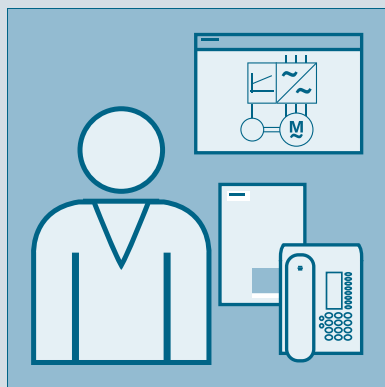

<b>6/2</b>	<b>Partner</b>
<b>6/3</b>	<b>Industry Services</b>
6/4	Industry Services – Portfolio overview
6/5	Online Support
<b>6/6</b>	<b>Training</b>
6/6	SITRAIN – Digital Industry Academy
6/7	SINAMICS S210 training case
<b>6/8</b>	<b>Applications</b>
<b>6/9</b>	<b>Drives Options Partner</b>
<b>6/10</b>	<b>mySupport documentation</b>
<b>6/11</b>	<b>Documentation</b>
6/12	General documentation
6/12	SINAMICS S210 documentation

## Services and documentation

### Partner

#### Partner at Siemens

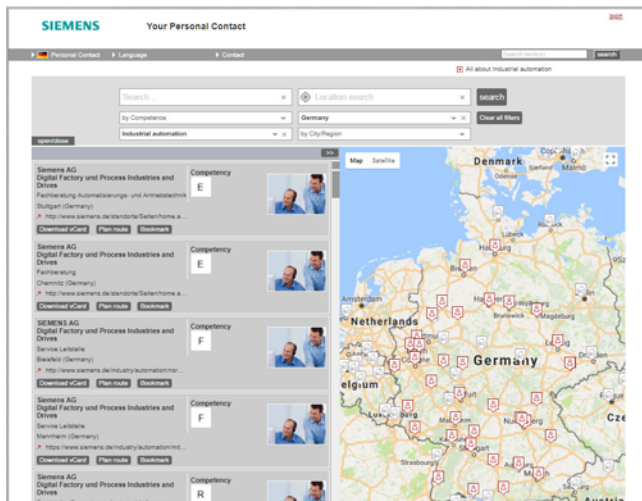

At your service locally, around the globe for consulting, sales, training, service, support, spare parts on the entire portfolio of Digital Industries.

Your partner can be found in our Personal Contacts Database at: [www.siemens.com/automation-contact](http://www.siemens.com/automation-contact)

You start by selecting

- the required competence,
- products and branches,
- a country and a city

or by a

- location search or free text search.

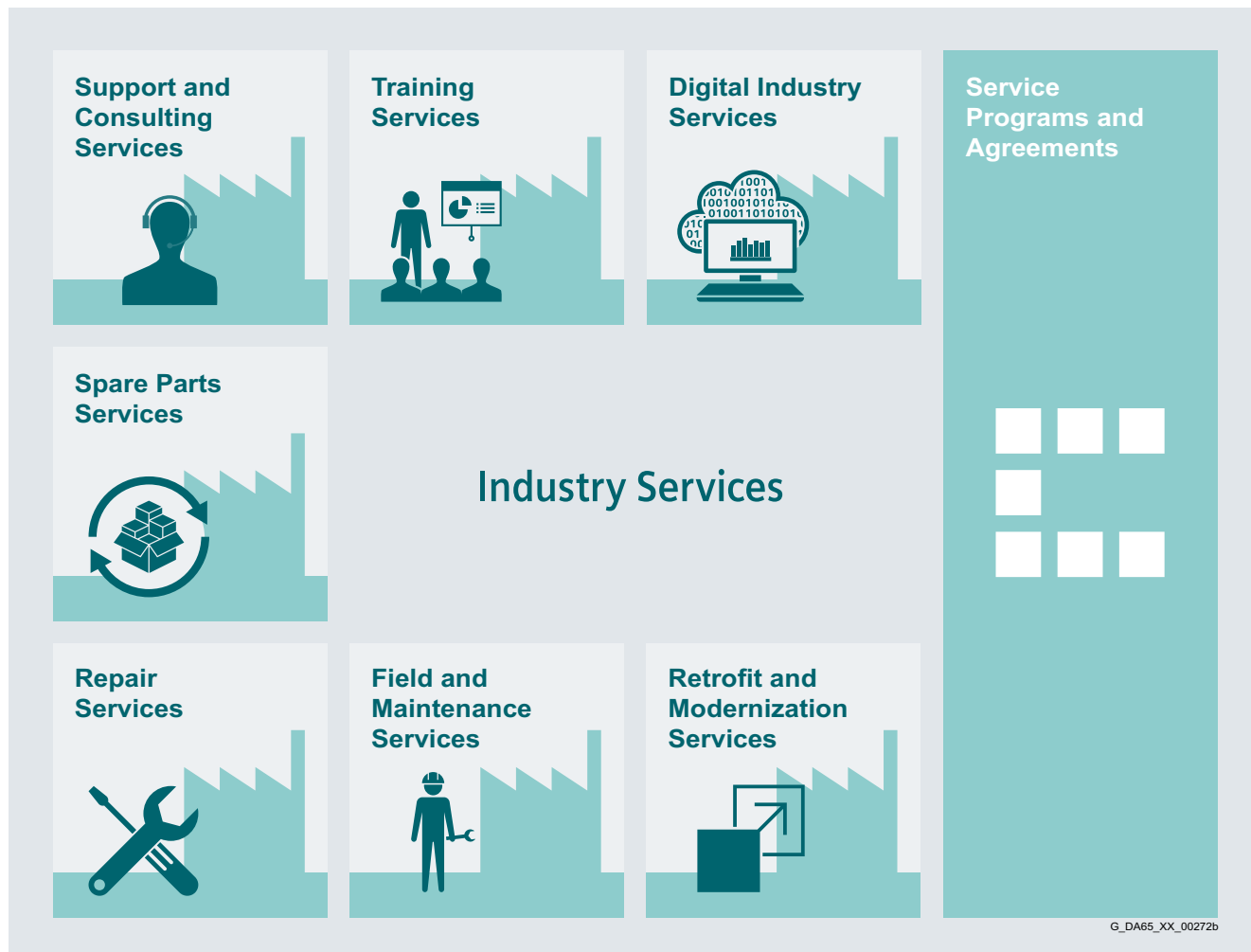

**Overview**

**Keep your business running and shaping your digital future – with Industry Services**

Optimizing the productivity of your equipment and operations can be a challenge, especially with constantly changing market conditions. Working with our service experts makes it easier. We understand your industry's unique processes and provide the services needed so that you can better achieve your business goals.

You can count on us to maximize your uptime and minimize your downtime, increasing your operations' productivity and reliability. When your operations have to be changed quickly to meet a new demand or business opportunity, our services give you the flexibility to adapt. Of course, we take care that your production is protected against cyber threats. We assist in keeping your operations as energy and resource efficient as possible and reducing your total cost of ownership. As a trendsetter, we ensure that you can capitalize on the opportunities of digitalization and by applying data analytics to enhance decision making: You can be sure that your plant reaches its full potential and retains this over the longer lifespan.

You can rely on our highly dedicated team of engineers, technicians and specialists to deliver the services you need – safely, professionally and in compliance with all regulations. We are there for you, where you need us, when you need us.

[www.siemens.com/industryservices](http://www.siemens.com/industryservices)

## Services and documentation

### Industry Services

#### Industry Services – Portfolio overview

##### Overview



#### Digital Industry Services

Digital Industry Services make your industrial processes transparent to gain improvements in productivity, asset availability, and energy efficiency.

Production data is generated, filtered and translated with intelligent analytics to enhance decision-making.

This is done whilst taking data security into consideration and with continuous protection against cyber-attack threats.

[www.siemens.com/global/en/products/services/industry/digital-industry-services.html](http://www.siemens.com/global/en/products/services/industry/digital-industry-services.html)

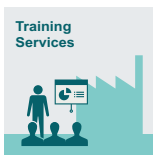

#### Training Services

From the basics and advanced to specialist skills, SITRAIN courses provide expertise right from the manufacturer – and encompass the entire spectrum of Siemens products and systems for the industry.

Worldwide, SITRAIN courses are available wherever you need a training course in more than 170 locations in over 60 countries.

<https://support.industry.siemens.com/cs/ww/en/sc/2226>

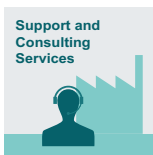

#### Support and Consulting Services

**Industry Online Support** site for comprehensive information, application examples, FAQs and support requests.

**Technical and Engineering Support** for advice and answers for all inquiries about functionality, handling, and fault clearance. The Service Card as prepaid support for value added services such as Priority Call Back or Extended Support offers the clear advantage of quick and easy purchasing.

**Information & Consulting Services**, e.g. SIMATIC System Audit; clarity about the state and service capability of your automation system or Lifecycle Information Services; transparency on the lifecycle of the products in your plants.

<https://support.industry.siemens.com/cs/ww/en/sc/2235>



#### Spare Parts

Spare Parts Services are available worldwide for smooth and fast supply of spare parts – and thus optimal plant availability. Genuine spare parts are available for up to ten years. Logistic experts take care of procurement, transport, custom clearance, storage and order management.

Reliable logistics processes ensure that components reach their destination as needed.

Since not all spare parts can be kept in stock at all times, Siemens offers a preventive measure for spare parts provisioning on the customer's premises with optimized **Spare Parts Packages** for individual products, custom-assembled drive components and entire integrated drive trains – including risk consulting.

**Asset Optimization Services** help you design a strategy for parts supply where your investment and carrying costs are reduced and the risk of obsolescence is avoided.

<https://support.industry.siemens.com/cs/ww/en/sc/2110>



#### Repair Services

Repair Services are offered on-site and in regional repair centers for fast restoration of faulty devices' functionality.

Also available are extended repair services, which include additional diagnostic and repair measures, as well as emergency services.

<https://support.industry.siemens.com/cs/ww/en/sc/2154>



#### Field and Maintenance Services

Siemens specialists are available globally to provide expert field and maintenance services, including commissioning, functional testing, preventive maintenance and fault clearance.

All services can be included in customized service agreements with defined reaction times or fixed maintenance intervals.

<https://support.industry.siemens.com/cs/ww/en/sc/2265>



#### Retrofit and Modernization Services

Provide a cost-effective solution for the expansion of entire plants, optimization of systems or upgrading existing products to the latest technology and software, e.g. migration services for automation systems.

Service experts support projects from planning through commissioning and, if desired over the entire extended lifespan, e.g. Retrofit for Integrated Drive Systems for an extended lifetime of your machines and plants.

<https://support.industry.siemens.com/cs/ww/en/sc/2286>



#### Service Programs and Agreements

A technical Service Program or Agreement enables you to easily bundle a wide range of services into a single annual or multi-year agreement.

You pick the services you need to match your unique requirements or fill gaps in your organization's maintenance capabilities.

Programs and agreements can be customized as KPI-based and/or performance-based contracts.

<https://support.industry.siemens.com/cs/ww/en/sc/2275>

Overview

Online Support – fast, intuitive, whenever you want, wherever you need

**Web**  
support.industry.siemens.com

**App**

Scan the QR code for information on our Online Support app.

**FAQ / Application examples**  
Information about industrial products, programming and configuration as well as application examples

**Technical information**  
Videos, documentation, manuals, updates, product notes, compatibility tool, certificates, planning data such as dimensional drawings, product data, 3D models

**Forum**  
Exchange information and experience with other users and experts

## Online Support for Siemens Industry Products

Siemens Industry and Online Support with some 1.7 million visitors per month is one of the most popular web services provided by Siemens. It is the central access point for comprehensive technical know-how about products, systems and services for automation and drives applications as well as for process industries.

In connection with the challenges and opportunities related to digitalization you can look forward to continued support with innovative offerings.

## Services and documentation

### Training

#### SITRAIN – Digital Industry Academy



#### Time for learning

Today's demands on our knowledge are every bit as diverse and dynamic as our profession itself. We keep learning more and longer – for our work, for our career and for ourselves. Advancing digitalization entails new topics and is also changing the way we absorb and process knowledge. SITRAIN – Digital Industry Academy offers the right source of knowledge here, which we can use anytime in just the way we need it. The time for learning is now.

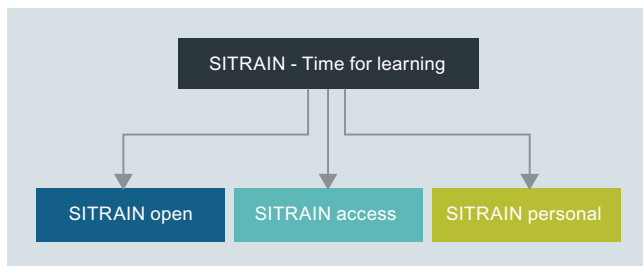

#### Knowledge for every need

With its three areas – SITRAIN open, SITRAIN access and SITRAIN personal – SITRAIN offers you an all-encompassing range of options for an ongoing expansion of your knowledge and skills, suited for every type of learner. And SITRAIN uses advancing digitalization to continuously expand content and offer new training methods.

Find  
your local  
offer here



**SITRAIN – Digital Industry Academy**  
Customer Support Germany

Tel.: +49 911 895-7575

E-Mail: [sitrain.digital.industry.academy.de@siemens.com](mailto:sitrain.digital.industry.academy.de@siemens.com)

#### Knowledge you can always find

SITRAIN open bundles useful information, worthwhile data and up-to-date expert knowledge about Siemens products for industry. Search it anytime, find anything – and always the right stuff.

#### Knowledge that gets you ahead

SITRAIN access is learning in the digital age. It offers you individualized ways to build your knowledge and access to exclusive digital training courses. Take advantage of sustainable learning success with a wide range of learning methods. Improve your skills – whether working in groups with others, or by yourself. Whenever, wherever and however you need to.

#### Knowledge you can experience

We all want to learn from the best. And SITRAIN personal's training courses let you benefit from our well-practiced trainers' expert knowledge, along with direct access to our training equipment. That's the best way to convey knowledge – whether at your company or in our training classrooms.

#### **SITRAIN – Digital Industry Academy**

[www.siemens.com/sitrain](http://www.siemens.com/sitrain)

- SITRAIN open:  
[www.siemens.com/sitrain-open](http://www.siemens.com/sitrain-open)
- SITRAIN access:  
[www.siemens.com/sitrain-access](http://www.siemens.com/sitrain-access)
- SITRAIN personal:  
[www.siemens.com/sitrain-personal](http://www.siemens.com/sitrain-personal)

**Overview**

SINAMICS S210 training case

The SINAMICS S210 training case is a convincing demonstration system thanks to its compact design. It is suitable for direct presentations as well as for tests in technical departments. The training case enables the functions of SINAMICS S210 servo drive system to be demonstrated and tested quickly and easily.

It contains the following components:

- 2 × SINAMICS S210 servo converters, 0.1 kW, 230 V 1 AC
- 2 × SIMOTICS S-1FK2 servomotors, High Dynamic
- 2 × One Cable Connection (OCC) motor connection cable
- Rail, prepared for installation of a controller, e.g. SIMATIC S7-1500 (controller not included in scope of delivery)

The SINAMICS S210 training case is supplied as a trolley with a hood.

**Technical specifications**

SINAMICS S210 training case	6AG1067-1AA33-0AA0
<b>Supply voltage</b>	230 V 1 AC
<b>Dimensions</b>	
• Width	420 mm (16.54 in)
• Height	580 mm (22.83 in)
• Depth	340 mm (13.39 in)
<b>Weight, approx.</b>	21 kg (46.3 lb)

**Selection and ordering data**

Description	Article No.
<b>SINAMICS S210 training case</b>	<b>6AG1067-1AA33-0AA0</b>

## Services and documentation

### Applications

#### Overview



Our understanding of an application is the customer-specific solution of an automation task based on standard hardware and software components. In this respect, industry knowledge and technological expertise are just as important as expert knowledge about how our products and systems work. We are setting ourselves this challenge with more than 280 application engineers in 20 countries.

#### Application centers

We currently have application centers in:

- Germany:
  - Head Office in Erlangen and in other German regions, e.g. in Munich, Nuremberg, Stuttgart, Mannheim, Frankfurt, Chemnitz, Cologne, Bielefeld, Bremen, Hanover, Hamburg
- Belgium: Brussels
- Brazil: Sao Paulo
- China: Beijing and 12 regions
- Denmark: Ballerup
- France: Paris
- Great Britain: Manchester
- India: Mumbai
- Italy: Bologna, Milan
- Japan: Tokyo, Osaka
- The Netherlands: The Hague
- Austria: Vienna
- Poland: Warsaw
- Sweden: Göteborg
- Switzerland: Zurich, Lausanne
- Spain: Madrid
- South Korea: Seoul
- Taiwan: Taipei
- Turkey: Istanbul
- USA: Atlanta

These application centers specialize in the use of SIMATIC/SIMOTION/SINAMICS. You therefore can rely on automation and drive specialists for implementing successful applications. By involving your personnel at an early stage in the process, we can provide a solid basis for rapid knowledge transfer, maintenance and further development of your automation solution.

#### Advice on applications and implementation

We offer a variety of consultation services to help you find the optimum solution for the SIMATIC/SIMOTION/SINAMICS application you want to implement:

The quotation phase includes

- clarification of technical questions,
- discussion of machine concepts and customer-specific solutions,
- selection of suitable technology and
- suggestions for implementation.

A technical feasibility study is also performed at the outset. In this way, difficult points of the application can be identified and solved early on. We can also configure and implement your application as a complete solution from a single source.

A large number of proven standard applications are available for use during the implementation phase. This saves engineering costs.

The system can be commissioned by experienced, competent personnel, if required. This saves time and trouble.

If servicing is required, we can support you on site or remotely. For further information about servicing, please see the section "Industry Services".

#### On-site application training

Training for the implemented applications can also be organized and carried out on site. This training for machine manufacturers and their customers does not deal with individual products, but the entire hardware and software system (for example, automation, drives and visualization).

From an initial concept to successful installation and commissioning: We provide complete support for SIMATIC/SIMOTION/SINAMICS! Contact your Siemens representative.

You can find further information at [www.siemens.com/machinebuilding](http://www.siemens.com/machinebuilding)

## Overview

### Siemens Product Partners for Drives Options

#### Individual options for our drives

In order to meet as many customer requirements as possible in the field of drive technology, in addition to its own products, Siemens also relies on the individual and complementary services of selected partners.

We are increasingly focusing on the standard drive options, and our Siemens Product Partners for Drives Options supplement our drives with individual drive options.

This gives Siemens a unique flexibility to meet all application requirements. Naturally, we support our Siemens Product Partners for Drives Options in tailoring their options perfectly to our drives.

For you as our customer, there are multiple benefits:

- The Siemens Product Partners for Drives Options meet the same high standards of quality and performance that we place on our own products
- Drive options can be adapted to individual requirements/designs
- The Siemens Product Partners for Drives Options know our Siemens converter portfolio and can advise you individually and quickly

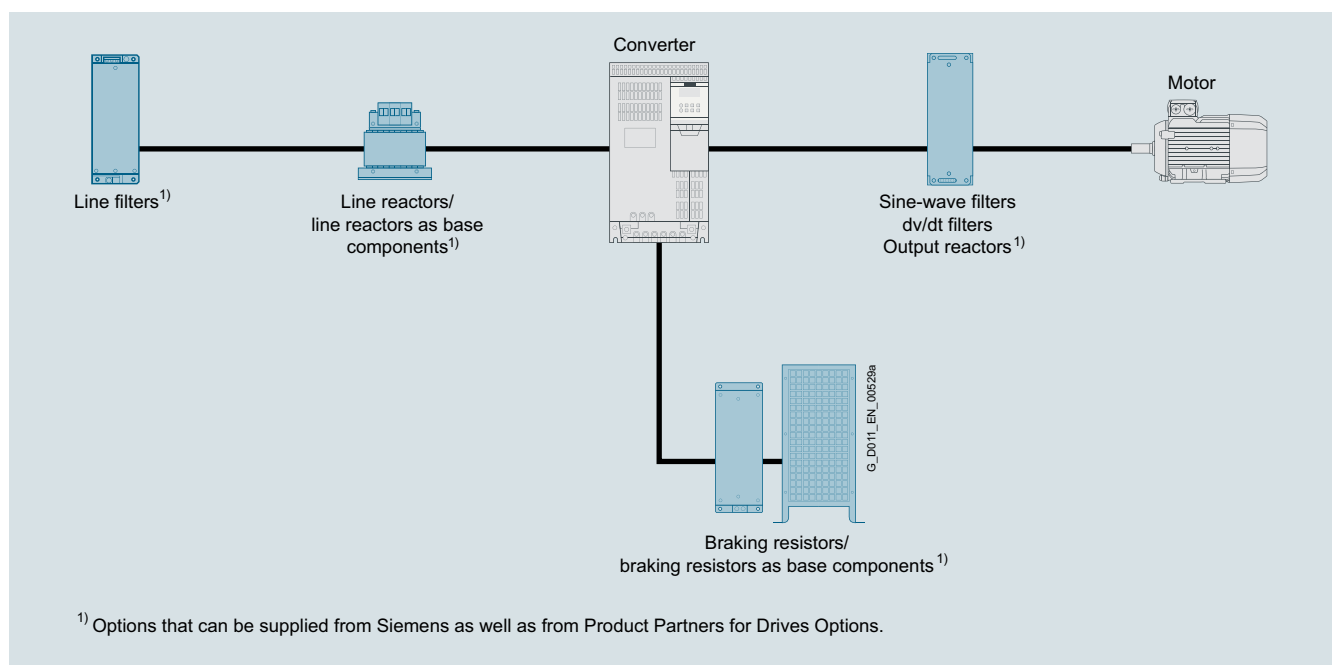

Schematic circuit diagram

## More information

You can find more information on the Internet at [www.siemens.com/drives-options-partner](http://www.siemens.com/drives-options-partner)

## Services and documentation

### mySupport documentation

#### Overview

#### mySupport documentation – Compiling personal documents

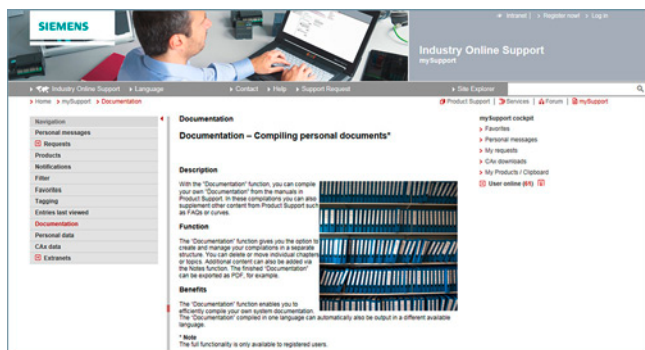

mySupport documentation is a web-based system for generating personalized documentation based on standard documents and is part of the Siemens Industry Online Support portal.

In mySupport, a personal document library can be created in the "Documentation" category. This library can be accessed online in mySupport or also be generated in various formats for offline use.

Previously, this functionality was available in the My Documentation Manager for configurable manuals. Due to the integration in mySupport, all entries of the Industry Online Support can now be imported into the personal document library, including FAQs or product notifications.

If you have already worked with the My Documentation Manager, all of the previously created libraries will continue to be available without restrictions in mySupport.

In addition, the personal library in mySupport can be shared with other mySupport users. In this way, a collection of relevant documents can be created very effectively and used together with other mySupport users all over the world.

You must register/log in for configuring and generating/managing.

#### Benefits

- Display  
View, print or download standard documents or personalized documents
- Configure  
Transfer standard documents or parts of them to personalized documents
- Generate/Manage  
Generate and manage personalized documents in the formats PDF, RTF or XML in all available languages

#### Function

##### Opening mySupport documentation in the Industry Online Support portal

- Via the product support, entry type "Manual":  
<https://support.industry.siemens.com/cs/ww/en/ps/manual>  
By clicking on the required version of the manual and then "Show and configure", the manual opens in a modular view, where you can navigate from topic to topic. Here the direct link to a topic can be used and made available to other users. The selected document can be added to the personal library via "mySupport Cockpit" > "Add to mySupport documentation".
- Via the direct link  
<https://support.industry.siemens.com/my/ww/en/documentation/advanced>  
After logon/registration, the online help is displayed as the current document.

#### More information

You can find additional information on the Internet at

- <https://support.industry.siemens.com/my/ww/en/documentation>
- [https://support.industry.siemens.com/cs/helpcenter/en/index.htm?#persoenliche\\_bibliothek\\_aufbauen.htm](https://support.industry.siemens.com/cs/helpcenter/en/index.htm?#persoenliche_bibliothek_aufbauen.htm)



### Overview

A high-quality programmable control or drive system can be used to maximum effect only if the user is aware of the performance of the products used as a result of intensive training and good technical documentation.

This is becoming more important due to the shorter innovation cycles of modern automation products and the convergence of electronics and mechanical engineering.

A comprehensive range of documentation is available which includes a Getting Started guide, operating instructions, installation manuals and a list manual.

The documents are available in hardcopy form or as a PDF file for downloading from the Internet.

Information and documentation relating to SINUMERIK, SINAMICS, SIMOTION and SIMOTICS are available on the Internet at <https://support.industry.siemens.com/cs/document/109476679>

### Application

#### *Explanations of the manuals:*

- **Operating Instructions**  
contain all the information needed to install the device and make electrical connections, information about commissioning and a description of the converter functions.  
Phases of use: Control cabinet construction, commissioning, operation, maintenance and servicing.
- **Hardware Installation Manual**  
contains all relevant information about the intended use of the components of a system (technical specifications, interfaces, dimensional drawings, characteristics, or possible applications), information about installation and electrical connections and information about maintenance and servicing.  
Phases of use: Control cabinet configuration/construction, maintenance and servicing.
- **Operating and Installation Instructions**  
(for converter and accessories)  
contain all relevant information about the intended use of the components, such as technical specifications, interfaces, dimensional drawings, characteristics, or possible applications.  
Phases of use: Control cabinet configuration/construction.
- **Manual/Configuration Manual**  
contains all necessary information about the intended use of the components of a system, e.g. technical specifications, interfaces, dimensional drawings, characteristics, or possible applications.  
Phases of use: Cabinet configuration/setup, circuit diagram configuration/drawing.
- **Commissioning Manual**  
contains all information relevant to commissioning after installation and wiring. It also contains all safety and warning notices relevant to commissioning in addition to overview drawings.  
Phases of use: Commissioning of components that have already been connected, configuration of system functions.
- **List Manual**  
contains all parameters, function diagrams, and faults/alarms for the product/system as well as their meanings and setting options. It contains parameter data and fault/alarm descriptions with functional correlations.  
Phases of use: Commissioning of components that have already been connected, configuration of system functions, fault cause/diagnosis.
- **Getting Started**  
provides information about getting started for the first-time user as well as references to additional information. It contains information about the basic steps to be taken during commissioning. The information in the other documentation should be carefully observed for all of the other work required.  
Phases of use: Commissioning of components that have already been connected.
- **Function Manual Drive Functions**  
contains all the relevant information about individual drive functions: Description, commissioning and integration in the drive system.  
Phases of use: Commissioning of components that have already been connected, configuration of system functions.

## Services and documentation

### Documentation

#### General documentation

##### Overview

Description	Article No.
<b>Decentralization with PROFIBUS DP/DPV1</b> <ul style="list-style-type: none"> <li>• German</li> <li>• English</li> </ul>	Via bookstore  <b>ISBN 978-3-89578-189-6</b> <b>ISBN 978-3-89578-218-3</b>
<b>Automating with PROFINET: Industrial Communication Based on Industrial Ethernet</b> <ul style="list-style-type: none"> <li>• German</li> <li>• English</li> </ul>	Via bookstore  <b>ISBN 978-3-89578-293-0</b> <b>ISBN 978-3-89578-294-7</b>

#### SINAMICS S210 documentation

##### Overview

A **Quick Installation Guide** is supplied in hard copy form in English with every SINAMICS S210. Further documentation, such as the operating instructions, is available free on the Internet at:

[www.siemens.com/sinamics-s210/documentation](http://www.siemens.com/sinamics-s210/documentation)

Detailed information on the SINAMICS S210 drive system, including the latest technical documentation (brochures, tutorials, dimensional drawings, certificates, manuals and operating instructions), is available on the Internet at:

[www.siemens.com/sinamics-s210](http://www.siemens.com/sinamics-s210)

and is also available via the Drive Technology Configurator (DT Configurator) on the Internet.

The DT Configurator can be found in the Siemens Industry Mall at the following address:

[www.siemens.com/dt-configurator](http://www.siemens.com/dt-configurator)

## Appendix



7/2	<b>Certificates of suitability (approvals)</b>
7/4	<b>Software licenses</b>
7/6	<b>Conversion tables</b>
7/8	<b>Metal surcharges</b>
7/11	<b>Conditions of sale and delivery</b>

## Appendix

### Certificates of suitability (approvals)





#### Overview

Many of the products in this catalog fulfill requirements, e.g. for UL, CSA or FM and are labeled with the corresponding approval designation.

All of the certificates of suitability, approvals, certificates, declarations of conformity, test certificates, e.g. CE, UL, Safety Integrated etc. have been performed with the associated system components as they are described in the Catalogs and Configuration Manuals.

The certificates are only valid if the products are used with the described system components, are installed according to the Installation Guidelines and used for their intended purpose.

In other cases, the vendor of these products is responsible for arranging for the issue of new certificates.

Test code	Tested by	Device series/ Component	Test standard	Product category/ File-No.
<b>UL: Underwriters Laboratories</b> Independent public testing body in North America				
	UL according to UL standard	SINUMERIK	Standard UL 508, CSA C22.2 No. 142	NRAQ/7.E164110 NRAQ/7.E217227
		SIMOTION	Standard UL 508, CSA C22.2 No. 142	NRAQ/7.E164110
	UL according to CSA standard	SINAMICS	Standard UL 508, 508C, 61800-5-1 CSA C22.2 No. 142, 274	NRAQ/7.E164110, NMMS/2/7/8.E192450, NMMS/7.E214113, NMMS/7.E253831
				NMMS/2/7/8.E121068 NMMS/7.E355661 NMMS/7.E323473
	UL according to UL and CSA standards	SIMODRIVE	Standard UL 508C, CSA C22.2 No. 274	NMMS/2/7/8.E192450 NMMS/7.E214113
				SIMOTICS
	UL according to UL and CSA standards	Line/motor reactors	Standard UL 508, 506, 5085-1, 5085-2, 1561, CSA C22.2 No. 14, 47, 66.1-06, 66.2-06	XQNX2/8.E257859 NMTR2/8.E219022 NMMS2/8.E333628 XPTQ2/8.E257852 XPTQ2/8.E103521 NMMS2/8.E224872 XPTQ2/8.E354316 XPTQ2/8.E198309 XQNX2/8.E475972
				Line filters, dv/dt filters, sine-wave filters
		Resistors	UL 508, 508C, CSA C22.2 No. 14, 274	NMTR2/8.E224314 NMMS2/8.E192450 NMTR2/8.E221095 NMTR2/8.E226619
<b>TUV: TÜV Rheinland of North America Inc.</b> Independent public testing body in North America, Nationally Recognized Testing Laboratory (NRTL)				
<b>TÜV: TÜV SÜD Product Service</b> Independent public testing body in Germany, Nationally Recognized Testing Laboratory (NRTL) for North America				
	TUV according to UL and CSA standards	SINAMICS	NRTL listing according to standard UL 508C	U7V 12 06 20078 013 U7 11 04 20078 009 U7 11 04 20078 010 U7 11 04 20078 011
		SIMOTION	NRTL listing according to standard UL 508	U7V 13 03 20078 01
		SIMODRIVE	NRTL listing according to standard UL 508C, CSA C22.2. No. 14	CU 72090702
		Motion Control Encoder	NRTL listing according to UL 61010-1 CSA C22.2 No. 61010-1	U8V 10 06 20196 024

## Certificates of suitability (approvals)

## Overview

Test code	Tested by	Device series/ Component	Test standard	Product category/ File-No.
<b>CSA: Canadian Standards Association</b> Independent public testing body in Canada				
	CSA according to CSA standard	SINUMERIK	Standard CSA C22.2 No. 142	2252-01 : LR 102527
<b>FMRC: Factory Mutual Research Corporation</b> Independent public testing body in North America				
	FM according to FM standard	SINUMERIK	Standard FMRC 3600, FMRC 3611, FMRC 3810, ANSI/ISA S82.02.1	-
<b>EAC: Ivanovo-Certificate</b> Independent public testing body in the Russian Federation				
	EAC in accordance with the EAC Directive	SINAMICS SINUMERIK SIMOTION	Standard IEC 61800-5-1/-2, IEC 61800-3	-
<b>RCM: Australian Communications and Media Authority</b> Independent public testing body in Australia				
	RCM according to EMC standard	SINAMICS SINUMERIK SIMOTION	Standard IEC AS 61800-3, EN 61800-3	-
<b>KC: National Radio Research Agency</b> Independent public testing body in South Korea				
	KC according to EMC standard	SINAMICS SINUMERIK SIMOTION	Standard KN 11	-
<b>BIA</b> Federal Institute for Occupational Safety				
-	Functional safety	SINAMICS SINUMERIK SIMOTION	Standard EN 61800-5-2	-
<b>TÜV SÜD Rail</b>				
-	Functional safety	SINAMICS SINUMERIK SIMOTION	Standard EN 61800-5-2	-

More information about certificates can be found online at:  
<https://support.industry.siemens.com/cs/ww/en/ps/cert>

## Appendix

### Software licenses

#### Overview

##### Software types

Software requiring a license is categorized into types. The following software types have been defined:

- Engineering software
- Runtime software

##### Engineering software

This includes all software products for creating (engineering) user software, e.g. for configuring, programming, parameterizing, testing, commissioning or servicing.

Data generated with engineering software and executable programs can be duplicated for your own use or for use by third-parties free-of-charge.

##### Runtime software

This includes all software products required for plant/machine operation, e.g. operating system, basic system, system expansions, drivers, etc.

The duplication of the runtime software and executable programs created with the runtime software for your own use or for use by third-parties is subject to a charge.

You can find information about license fees according to use in the ordering data (e.g. in the catalog). Examples of categories of use include per CPU, per installation, per channel, per instance, per axis, per control loop, per variable, etc.

Information about extended rights of use for parameterization/configuration tools supplied as integral components of the scope of supply can be found in the readme file supplied with the relevant product(s).

##### License types

Siemens Industry Automation & Drive Technologies offers various types of software license:

- Floating license
- Single license
- Rental license
- Rental floating license
- Trial license
- Demo license
- Demo floating license

##### Floating license

The software may be installed for internal use on any number of devices by the licensee. Only the concurrent user is licensed. The concurrent user is the person using the program. Use begins when the software is started. A license is required for each concurrent user.

##### Single license

Unlike the floating license, a single license permits only one installation of the software per license.

The type of use licensed is specified in the ordering data and in the Certificate of License (CoL). Types of use include for example per instance, per axis, per channel, etc.

One single license is required for each type of use defined.

##### Rental license

A rental license supports the "sporadic use" of engineering software. Once the license key has been installed, the software can be used for a specific period of time (the operating hours do not have to be consecutive).

One license is required for each installation of the software.

##### Rental floating license

The rental floating license corresponds to the rental license, except that a license is not required for each installation of the software. Rather, one license is required per object (for example, user or device).

##### Trial license

A trial license supports "short-term use" of the software in a non-productive context, e.g. for testing and evaluation purposes. It can be transferred to another license.

##### Demo license

The demo license support the "sporadic use" of engineering software in a non-productive context, for example, use for testing and evaluation purposes. It can be transferred to another license. After the installation of the license key, the software can be operated for a specific period of time, whereby usage can be interrupted as often as required.

One license is required per installation of the software.

##### Demo floating license

The demo floating license corresponds to the demo license, except that a license is not required for each installation of the software. Rather, one license is required per object (for example, user or device).

##### Certificate of License (CoL)

The CoL is the licensee's proof that the use of the software has been licensed by Siemens. A CoL is required for every type of use and must be kept in a safe place.

##### Downgrading

The licensee is permitted to use the software or an earlier version/release of the software, provided that the licensee owns such a version/release and its use is technically feasible.

##### Delivery versions

Software is constantly being updated. The following delivery versions

- PowerPack
- Upgrade

can be used to access updates.

Existing bug fixes are supplied with the ServicePack version.

##### PowerPack

PowerPacks can be used to upgrade to more powerful software. The licensee receives a new license agreement and CoL (Certificate of License) with the PowerPack. This CoL, together with the CoL for the original product, proves that the new software is licensed.

A separate PowerPack must be purchased for each original license of the software to be replaced.

##### Upgrade

An upgrade permits the use of a new version of the software on the condition that a license for a previous version of the product is already held.

The licensee receives a new license agreement and CoL with the upgrade. This CoL, together with the CoL for the previous product, proves that the new version is licensed.

A separate upgrade must be purchased for each original license of the software to be upgraded.

## Overview

### *ServicePack*

ServicePacks are used to debug existing products. ServicePacks may be duplicated for use as prescribed according to the number of existing original licenses.

### *License key*

Siemens Industry Automation & Drive Technologies supplies software products with and without license keys.

The license key serves as an electronic license stamp and is also the "switch" for activating the software (floating license, rental license, etc.).

The complete installation of software products requiring license keys includes the program to be licensed (the software) and the license key (which represents the license).

### *Software Update Service (SUS)*

As part of the SUS contract, all software updates for the respective product are made available to you free of charge for a period of one year from the invoice date. The contract will automatically be extended for one year if it is not canceled three months before it expires.

The possession of the current version of the respective software is a basic condition for entering into an SUS contract.

You can download explanations concerning license conditions from [https://mall.industry.siemens.com/legal/ww/en/terms\\_of\\_trade\\_en.pdf](https://mall.industry.siemens.com/legal/ww/en/terms_of_trade_en.pdf)

## Appendix

### Conversion tables

**Rotary inertia** (to convert from A to B, multiply by entry in table)

A \ B	lb-in <sup>2</sup>	lb-ft <sup>2</sup>	lb-in-s <sup>2</sup>	lb-ft-s <sup>2</sup> slug-ft <sup>2</sup>	kg-cm <sup>2</sup>	kg-cm-s <sup>2</sup>	gm-cm <sup>2</sup>	gm-cm-s <sup>2</sup>	oz-in <sup>2</sup>	oz-in-s <sup>2</sup>
lb-in <sup>2</sup>	1	$6.94 \times 10^{-3}$	$2.59 \times 10^{-3}$	$2.15 \times 10^{-4}$	2.926	$2.98 \times 10^{-3}$	$2.92 \times 10^3$	2.984	16	$4.14 \times 10^{-2}$
lb-ft <sup>2</sup>	144	1	0.3729	$3.10 \times 10^{-2}$	421.40	0.4297	$4.21 \times 10^5$	429.71	2304	5.967
lb-in-s <sup>2</sup>	386.08	2.681	1	$8.33 \times 10^{-2}$	$1.129 \times 10^3$	1.152	$1.129 \times 10^6$	$1.152 \times 10^3$	$6.177 \times 10^3$	16
lb-ft-s <sup>2</sup> slug-ft <sup>2</sup>	$4.63 \times 10^3$	32.17	12	1	$1.35 \times 10^4$	13.825	$1.355 \times 10^7$	$1.38 \times 10^4$	$7.41 \times 10^4$	192
kg-cm <sup>2</sup>	0.3417	$2.37 \times 10^{-3}$	$8.85 \times 10^{-4}$	$7.37 \times 10^{-5}$	1	$1.019 \times 10^{-3}$	1000	1.019	5.46	$1.41 \times 10^{-2}$
kg-cm-s <sup>2</sup>	335.1	2.327	0.8679	$7.23 \times 10^{-2}$	980.66	1	$9.8 \times 10^5$	1000	$5.36 \times 10^3$	13.887
gm-cm <sup>2</sup>	$3.417 \times 10^{-4}$	$2.37 \times 10^{-6}$	$8.85 \times 10^{-7}$	$7.37 \times 10^{-8}$	$1 \times 10^{-3}$	$1.01 \times 10^{-6}$	1	$1.01 \times 10^{-3}$	$5.46 \times 10^{-3}$	$1.41 \times 10^{-5}$
gm-cm-s <sup>2</sup>	0.335	$2.32 \times 10^{-3}$	$8.67 \times 10^{-4}$	$7.23 \times 10^{-5}$	0.9806	$1 \times 10^{-3}$	980.6	1	5.36	$1.38 \times 10^{-2}$
oz-in <sup>2</sup>	0.0625	$4.34 \times 10^{-4}$	$1.61 \times 10^{-4}$	$1.34 \times 10^{-5}$	0.182	$1.86 \times 10^{-4}$	182.9	0.186	1	$2.59 \times 10^{-3}$
oz-in-s <sup>2</sup>	24.13	0.1675	$6.25 \times 10^{-2}$	$5.20 \times 10^{-3}$	70.615	$7.20 \times 10^{-2}$	$7.09 \times 10^4$	72.0	386.08	1

**Torque** (to convert from A to B, multiply by entry in table)

A \ B	lb-in	lb-ft	oz-in	N-m	kg-cm	kg-m	gm-cm	dyne-cm
lb-in	1	$8.333 \times 10^{-2}$	16	0.113	1.152	$1.152 \times 10^{-2}$	$1.152 \times 10^3$	$1.129 \times 10^6$
lb-ft	12	1	192	1.355	13.825	0.138	$1.382 \times 10^4$	$1.355 \times 10^7$
oz-in	$6.25 \times 10^{-2}$	$5.208 \times 10^{-3}$	1	$7.061 \times 10^{-3}$	$7.200 \times 10^{-2}$	$7.200 \times 10^{-4}$	72.007	$7.061 \times 10^4$
N-m	8.850	0.737	141.612	1	10.197	0.102	$1.019 \times 10^4$	$1 \times 10^7$
kg-cm	0.8679	$7.233 \times 10^{-2}$	13.877	$9.806 \times 10^{-2}$	1	$10^{-2}$	1000	$9.806 \times 10^5$
kg-m	86.796	7.233	$1.388 \times 10^3$	9.806	100	1	$1 \times 10^5$	$9.806 \times 10^7$
gm-cm	$8.679 \times 10^{-4}$	$7.233 \times 10^{-5}$	$1.388 \times 10^{-2}$	$9.806 \times 10^{-5}$	$1 \times 10^{-3}$	$1 \times 10^{-5}$	1	980.665
dyne-cm	$8.850 \times 10^{-7}$	$7.375 \times 10^{-8}$	$1.416 \times 10^{-5}$	$10^{-7}$	$1.0197 \times 10^{-6}$	$1.019 \times 10^{-8}$	$1.019 \times 10^{-3}$	1

**Length** (to convert from A to B, multiply by entry in table)

A \ B	inches	feet	cm	yd	mm	m
inches	1	0.0833	2.54	0.028	25.4	0.0254
feet	12	1	30.48	0.333	304.8	0.3048
cm	0.3937	0.03281	1	$1.09 \times 10^{-2}$	10	0.01
yd	36	3	91.44	1	914.4	0.914
mm	0.03937	0.00328	0.1	$1.09 \times 10^{-3}$	1	0.001
m	39.37	3.281	100	1.09	1000	1

**Force** (to convert from A to B, multiply by entry in table)

A \ B	lb	oz	gm	dyne	N
lb	1	16	453.6	$4.448 \times 10^5$	4.4482
oz	0.0625	1	28.35	$2.780 \times 10^4$	0.27801
gm	$2.205 \times 10^{-3}$	0.03527	1	$1.02 \times 10^{-3}$	N.A.
dyne	$2.248 \times 10^{-6}$	$3.59 \times 10^{-5}$	980.7	1	0.00001
N	0.22481	3.5967	N.A.	100000	1

**Mass** (to convert from A to B, multiply by entry in table)

A \ B	lb	oz	gm	kg	slug
lb	1	16	453.6	0.4536	0.0311
oz	$6.25 \times 10^{-2}$	1	28.35	0.02835	$1.93 \times 10^{-3}$
gm	$2.205 \times 10^{-3}$	$3.527 \times 10^{-2}$	1	$10^{-3}$	$6.852 \times 10^{-5}$
kg	2.205	35.27	$10^3$	1	$6.852 \times 10^{-2}$
slug	32.17	514.8	$1.459 \times 10^4$	14.59	1

**Rotation** (to convert from A to B, multiply by entry in table)

A \ B	rpm	rad/s	degrees/s
rpm	1	0.105	6.0
rad/s	9.55	1	57.30
degrees/s	0.167	$1.745 \times 10^{-2}$	1

**Power** (to convert from A to B, multiply by entry in table)

A \ B	hp	Watts
hp (English)	1	745.7
(lb-in) (deg./s)	$2.645 \times 10^{-6}$	$1.972 \times 10^{-3}$
(lb-in) (rpm)	$1.587 \times 10^{-5}$	$1.183 \times 10^{-2}$
(lb-ft) (deg./s)	$3.173 \times 10^{-5}$	$2.366 \times 10^{-2}$
(lb-ft) (rpm)	$1.904 \times 10^{-4}$	0.1420
Watts	$1.341 \times 10^{-3}$	1



**Temperature Conversion**

°F	°C	°C	°F
0	-17.8	-10	14
32	0	0	32
50	10	10	50
70	21.1	20	68
90	32.2	30	86
98.4	37	37	98.4
212	100	100	212
subtract 32 and multiply by $\frac{5}{9}$		multiply by $\frac{9}{5}$ and add 32	

**Mechanism Efficiencies**

Acme-screw with brass nut	~0.35–0.65
Acme-screw with plastic nut	~0.50–0.85
Ball-screw	~0.85–0.95
Chain and sprocket	~0.95–0.98
Preloaded ball-screw	~0.75–0.85
Spur or bevel-gears	~0.90
Timing belts	~0.96–0.98
Worm gears	~0.45–0.85
Helical gear (1 reduction)	~0.92

**Friction Coefficients**

Materials	$\mu$
Steel on steel (greased)	~0.15
Plastic on steel	~0.15–0.25
Copper on steel	~0.30
Brass on steel	~0.35
Aluminum on steel	~0.45
Steel on steel	~0.58
Mechanism	$\mu$
Ball bushings	<0.001
Linear bearings	<0.001
Dove-tail slides	~0.2++
Gibb ways	~0.5++

**Material Densities**

Material	lb-in <sup>3</sup>	gm-cm <sup>3</sup>
Aluminum	0.096	2.66
Brass	0.299	8.30
Bronze	0.295	8.17
Copper	0.322	8.91
Hard wood	0.029	0.80
Soft wood	0.018	0.48
Plastic	0.040	1.11
Glass	0.079–0.090	2.2–2.5
Titanium	0.163	4.51
Paper	0.025–0.043	0.7–1.2
Polyvinyl chloride	0.047–0.050	1.3–1.4
Rubber	0.033–0.036	0.92–0.99
Silicone rubber, without filler	0.043	1.2
Cast iron, gray	0.274	7.6
Steel	0.280	7.75

**Wire Gauges<sup>1)</sup>**

Cross-section mm <sup>2</sup>	Standard Wire Gauge (SWG)	American Wire Gauge (AWG)
0.2	25	24
0.3	23	22
0.5	21	20
0.75	20	19
1.0	19	18
1.5	17	16
2.5	15	13
4	13	11
6	12	9
10	9	7
16	7	6
25	5	3
35	3	2
50	0	1/0
70	000	2/0
95	00000	3/0
120	0000000	4/0
150	–	6/0
185	–	7/0

<sup>1)</sup> The table shows approximate SWG/AWG sizes nearest to standard metric sizes; the cross-sections do not match exactly.

## Appendix

### Metal surcharges

#### Explanation of the raw material/metal surcharges <sup>1)</sup>

##### Surcharge calculation

To compensate for variations in the price of the raw materials silver, copper, aluminum, lead, gold, dysprosium <sup>2)</sup> and/or neodym <sup>2)</sup>, surcharges are calculated on a daily basis using the so-called metal factor for products containing these raw materials. A surcharge for the respective raw material is calculated as a supplement to the price of a product if the basic official price of the raw material in question is exceeded.

The surcharges are calculated in accordance with the following criteria:

- Basic official price of the raw material  
Basic official price from the day prior to receipt of the order or prior to release order (daily price) for <sup>3)</sup>  
- Silver (sales price, processed)  
- Gold (sales price, processed)  
and for <sup>4)</sup>  
- Copper (lower DEL notation + 1 %)  
- Aluminum (aluminum in cables)  
- Lead (lead in cables)
- Metal factor of the products  
Certain products are displayed with a metal factor. The metal factor determines the official price (for those raw materials concerned) as of which the metal surcharges are applied and the calculation method used (weight or percentage method). An exact explanation is given below.

##### Structure of the metal factor

The metal factor consists of several digits; the first digit indicates whether the percentage method of calculation refers to the list price or a possible discounted price (customer net price) (L = list price / N = customer net price).

The remaining digits indicate the method of calculation used for the respective raw material. If no surcharge is added for a raw material, a "-" is used.

1st digit	List or customer net price using the percentage method
2nd digit	for silver (AG)
3rd digit	for copper (CU)
4th digit	for aluminum (AL)
5th digit	for lead (PB)
6th digit	for gold (AU)
7th digit	for dysprosium (Dy) <sup>2)</sup>
8th digit	for neodym (Nd) <sup>2)</sup>

##### Weight method

The weight method uses the basic official price, the daily price and the raw material weight. In order to calculate the surcharge, the basic official price must be subtracted from the daily price. The difference is then multiplied by the raw material weight.

The basic official price can be found in the table below using the number (1 to 9) of the respective digit of the metal factor. The raw material weight can be found in the respective product descriptions.

##### Percentage method

Use of the percentage method is indicated by the letters A-Z at the respective digit of the metal factor.

The surcharge is increased - dependent on the deviation of the daily price compared with the basic official price - using the percentage method in "steps" and consequently offers surcharges that remain constant within the framework of this "step range". A higher percentage rate is charged for each new step. The respective percentage level can be found in the table below.

##### Metal factor examples

<b>L E A</b> - - - - -	Basis for % surcharge: List price
	Silver Basis 150 €, Step 50 €, 0.5 %
	Copper Basis 150 €, Step 50 €, 0.1 %
	No surcharge for aluminum
	No surcharge for lead
	No surcharge for gold
	No surcharge for dysprosium
	No surcharge for neodym

<b>N - A 6</b> - - - - -	Basis for % surcharge: Customer net price
	No surcharge for silver
	Copper Basis 150 €, Step 50 €, 0.1 %
	Aluminum acc. to weight, basic offic. price 225 €
	No surcharge for lead
	No surcharge for gold
	No surcharge for dysprosium
	No surcharge for neodym

- - <b>3</b> - - - - -	No basis necessary
	No surcharge for silver
	Copper acc. to weight, basic official price 150 €
	No surcharge for aluminum
	No surcharge for lead
	No surcharge for gold
	No surcharge for dysprosium
	No surcharge for neodym

<sup>1)</sup> Refer to the separate explanation on the next page regarding the raw materials dysprosium and neodym (= rare earths).  
<sup>2)</sup> For a different method of calculation, refer to the separate explanation for these raw materials on the next page.  
<sup>3)</sup> Source: Umicore, Hanau ([www.metalsmanagement.umicore.com](http://www.metalsmanagement.umicore.com)).  
<sup>4)</sup> Source: Schutzvereinigung DEL-Notiz e.V. ([www.del-notiz.org](http://www.del-notiz.org)).

## Explanation of the raw material/metal surcharges for dysprosium and neodym (rare earths)

### Surcharge calculation

To compensate for variations in the price of the raw materials silver <sup>1)</sup>, copper <sup>1)</sup>, aluminum <sup>1)</sup>, lead <sup>1)</sup>, gold <sup>1)</sup>, dysprosium and/or neodym, surcharges are calculated on a daily basis using the so-called metal factor for products containing these raw materials. The surcharge for dysprosium and neodym is calculated as a supplement to the price of a product if the basic official price of the raw material in question is exceeded.

The surcharge is calculated in accordance with the following criteria:

- Basic official price of the raw material <sup>2)</sup>  
Three-month basic average price (see below) in the period before the quarter in which the order was received or the release order took place (= average official price) for  
- dysprosium (Dy metal, 99 % min. FOB China; USD/kg)  
- neodym (Nd metal, 99 % min. FOB China; USD/kg)
- Metal factor of the products  
Certain products are displayed with a metal factor. The metal factor indicates (for those raw materials concerned) the basic official price as of which the surcharges for dysprosium and neodym are calculated using the weight method. An exact explanation of the metal factor is given below.

### Three-month average price

The prices of rare earths vary according to the foreign currency, and there is no freely accessible stock exchange listing. This makes it more difficult for all parties involved to monitor changes in price. In order to avoid continuous adjustment of the surcharges, but to still ensure fair, transparent pricing, an average price is calculated over a three-month period using the average monthly foreign exchange rate from USD to EUR (source: European Central Bank). Since not all facts are immediately available at the start of each month, a one-month buffer is allowed before the new average price applies.

Examples of calculation of the average official price:

Period for calculation of the average price:	Period during which the order/release order is effected and the average price applies:
Sep 2012 - Nov 2012	Q1 in 2013 (Jan - Mar)
Dec 2012 - Feb 2013	Q2 in 2013 (Apr - Jun)
Mar 2013 - May 2013	Q3 in 2013 (Jul - Sep)
Jun 2013 - Aug 2013	Q4 in 2013 (Oct - Dec)

### Structure of the metal factor

The metal factor consists of several digits; the first digit is not relevant to the calculation of dysprosium and neodym.

The remaining digits indicate the method of calculation used for the respective raw material. If no surcharge is added for a raw material, a "-" is used.

1st digit	List or customer net price using the percentage method
2nd digit	for silver (AG) <sup>1)</sup>
3rd digit	for copper (CU) <sup>1)</sup>
4th digit	for aluminum (AL) <sup>1)</sup>
5th digit	for lead (PB) <sup>1)</sup>
6th digit	for gold (AU) <sup>1)</sup>
7th digit	for dysprosium (Dy)
8th digit	for neodym (Nd)

### Weight method

The weight method uses the basic official price, the average price and the raw material weight. In order to calculate the surcharge, the basic official price must be subtracted from the average price. The difference is then multiplied by the raw material weight.

The basic official price can be found in the table below using the number (1 to 9) of the respective digit of the metal factor. Your Sales contact can inform you of the raw material weight.

### Metal factor examples

Metal factor	Description
-----71	No basis necessary
	No surcharge for silver
	No surcharge for copper
	No surcharge for aluminum
	No surcharge for lead
	No surcharge for gold
	Dysprosium acc. to weight, basic official price 300 €
	Neodym acc. to weight, basic official price 50 €

<sup>1)</sup> For a different method of calculation, refer to the separate explanation for these raw materials on the previous page.

<sup>2)</sup> Source: Asian Metal Ltd ([www.asianmetal.com](http://www.asianmetal.com))

## Appendix

### Metal surcharges

#### Values of the metal factor

Percentage method	Basic official price in €	Step range in €	% surcharge 1st step	% surcharge 2nd step	% surcharge 3rd step	% surcharge 4th step	% surcharge per additional step	
			Price in € 150.01 - 200.00	Price in € 200.01 - 250.00	Price in € 250.01 - 300.00	Price in € 300.01 - 350.00		
A	150	50	0.1	0.2	0.3	0.4	0.1	
B	150	50	0.2	0.4	0.6	0.8	0.2	
C	150	50	0.3	0.6	0.9	1.2	0.3	
D	150	50	0.4	0.8	1.2	1.6	0.4	
E	150	50	0.5	1.0	1.5	2.0	0.5	
F	150	50	0.6	1.2	1.8	2.4	0.6	
G	150	50	1.0	2.0	3.0	4.0	1.0	
H	150	50	1.2	2.4	3.6	4.8	1.2	
I	150	50	1.6	3.2	4.8	6.4	1.6	
J	150	50	1.8	3.6	5.4	7.2	1.8	
			175.01 - 225.00	225.01 - 275.00	275.01 - 325.00	325.01 - 375.00		
O	175	50	0.1	0.2	0.3	0.4	0.1	
P	175	50	0.2	0.4	0.6	0.8	0.2	
R	175	50	0.5	1.0	1.5	2.0	0.5	
			225.01 - 275.00	275.01 - 325.00	325.01 - 375.00	375.01 - 425.00		
S	225	50	0.2	0.4	0.6	0.8	0.2	
U	225	50	1.0	2.0	3.0	4.0	1.0	
V	225	50	1.0	1.5	2.0	3.0	1.0	
W	225	50	1.2	2.5	3.5	4.5	1.0	
			150.01 - 175.00	175.01 - 200.00	200.01 - 225.00	225.01 - 250.00		
Y	150	25	0.3	0.6	0.9	1.2	0.3	
			400.01 - 425.00	425.01 - 450.00	450.01 - 475.00	475.01 - 500.00		
Z	400	25	0.1	0.2	0.3	0.4	0.1	
<b>Price basis (1st digit)</b>								
L	Calculation based on the list price							
N	Calculation based on the customer net price (discounted list price)							
<b>Weight method</b>	<b>Basic official price in €</b>							
1	50	Calculation based on raw material weight						
2	100							
3	150							
4	175							
5	200							
6	225							
7	300							
8	400							
9	555							
<b>Miscellaneous</b>								
-	No metal surcharge							

## 1. General Provisions

By using this catalog you can purchase products (hardware, software and services) described therein from Siemens Aktiengesellschaft subject to the following Terms and Conditions of Sale and Delivery (hereinafter referred to as "T&C"). Please note that the scope, the quality and the conditions for supplies and services, including software products, by any Siemens entity having a registered office outside Germany, shall be subject exclusively to the General Terms and Conditions of the respective Siemens entity. The following T&C apply exclusively for orders placed with Siemens Aktiengesellschaft, Germany.

### 1.1 For customers with a seat or registered office in Germany

For customers with a seat or registered office in Germany, the following terms and conditions apply subordinate to T&C:

- for products, which include specific terms and conditions in the description text, these specific terms and conditions shall apply and subordinate thereto,
- for installation work the "General Conditions for Erection Works – Germany" ("Allgemeine Montagebedingungen – Deutschland" (currently only available in German)) and/or
- for stand-alone software products and software products forming a part of a product or project, the "General License Conditions for Software Products for Automation and Drives for Customers with a Seat or registered Office in Germany" <sup>1)</sup> and/or
- for consulting services the "General Terms and Conditions for Consulting Services of the Division DF – Germany" <sup>1)</sup> and/or
- for other supplies and/or services the "General Conditions for the Supply of Products and Services of the Electrical and Electronics Industry" <sup>1)</sup>.

In case such supplies and/or services should contain Open Source Software, the conditions of which shall prevail over the "General Conditions for the Supply of Products and Services of the Electrical and Electronics Industry" <sup>1)</sup>, a notice will be contained in the scope of delivery in which the applicable conditions for Open Source Software are specified. This shall apply mutatis mutandis for notices referring to other third party software components.

### 1.2 For customers with a seat or registered office outside Germany

For customers with a seat or registered office outside Germany, the following terms and conditions apply subordinate to T&C:

- for products, which include specific terms and conditions in the description text, these specific terms and conditions shall apply and subordinate thereto,
- for services the "International Terms & Conditions for Services" <sup>1)</sup> supplemented by "Software Licensing Conditions" <sup>1)</sup> and/or
- for consulting services the "General Terms and Conditions for Consulting Services of the Division DF – Germany" <sup>1)</sup> and/or
- for other supplies of hard- and software the "International Terms Conditions for Products" <sup>1)</sup> supplemented by "Software Licensing Conditions" <sup>1)</sup>

### 1.3 For customers with master or framework agreement

To the extent our supplies and/or services offered are covered by an existing master or framework agreement, the terms and conditions of that agreement shall apply instead of T&C.

## 2. Prices

The prices are in € (Euro) ex point of delivery, exclusive of packaging.

The sales tax (value added tax) is not included in the prices. It shall be charged separately at the respective rate according to the applicable statutory legal regulations.

Prices are subject to change without prior notice. We will charge the prices valid at the time of delivery.

To compensate for variations in the price of raw materials (e.g. silver, copper, aluminum, lead, gold, dysprosium and neodym), surcharges are calculated on a daily basis using the so-called metal factor for products containing these raw materials.

A surcharge for the respective raw material is calculated as a supplement to the price of a product if the basic official price of the raw material in question is exceeded.

The metal factor of a product indicates the basic official price (for those raw materials concerned) as of which the surcharges on the price of the product are applied, and with what method of calculation.

You will find a detailed explanation of the metal factor on the page headed "Metal surcharges".

To calculate the surcharge (except in the cases of dysprosium and neodym), the official price from the day prior to that on which the order was received or the release order was effected is used.

To calculate the surcharge applicable to dysprosium and neodym ("rare earths"), the corresponding three-month basic average price in the quarter prior to that in which the order was received or the release order was effected is used with a one-month buffer (details on the calculation can be found in the explanation of the metal factor).

## 3. Additional Terms and Conditions

The dimensions are in mm. In Germany, according to the German law on units in measuring technology, data in inches apply only to devices for export.

Illustrations are not binding.

Insofar as there are no remarks on the individual pages of this catalog – especially with regard to data, dimensions and weights given – these are subject to change without prior notice.

<sup>1)</sup> The text of the Terms and Conditions of Siemens AG can be downloaded at [www.siemens.com/automation/salesmaterial-as/catalog/en/terms\\_of\\_trade\\_en.pdf](http://www.siemens.com/automation/salesmaterial-as/catalog/en/terms_of_trade_en.pdf)

## Appendix

### Conditions of sale and delivery

#### 4. Export Regulations

We shall not be obligated to fulfill any agreement if such fulfillment is prevented by any impediments arising out of national or international foreign trade or customs requirements or any embargoes and/or other sanctions.

Export may be subject to license. We shall indicate in the delivery details whether licenses are required under German, European and US export lists.

Our products are controlled by the U.S. Government (when labeled with "ECCN" unequal "N") and authorized for export only to the country of ultimate destination for use by the ultimate consignee or end-user(s) herein identified. They may not be resold, transferred, or otherwise disposed of, to any other country or to any person other than the authorized ultimate consignee or end-user(s), either in their original form or after being incorporated into other items, without first obtaining approval from the U.S. Government or as otherwise authorized by U.S. law and regulations.

The export indications can be viewed in advance in the description of the respective goods on the Industry Mall, our online catalog system. Only the export labels "AL" and "ECCN" indicated on order confirmations, delivery notes and invoices are authoritative.

Products labeled with "AL" unequal "N" are subject to European / national export authorization. Products without label, with label "AL:N" / "ECCN:N", or label "AL:9X9999" / "ECCN: 9X9999" may require authorization from responsible authorities depending on the final end-use, or the destination.

If you transfer goods (hardware and/or software and/or technology as well as corresponding documentation, regardless of the mode of provision) delivered by us or works and services (including all kinds of technical support) performed by us to a third party worldwide, you must comply with all applicable national and international (re-)export control regulations.

If required for the purpose of conducting export control checks, you (upon request by us) shall promptly provide us with all information pertaining to the particular end customer, final disposition and intended use of goods delivered by us respectively works and services provided by us, as well as to any export control restrictions existing in this relation.

The products listed in this catalog may be subject to European / German and/or US export regulations. Any export requiring approval is therefore subject to authorization by the relevant authorities.

Errors excepted and subject to change without prior notice.

## Selection and ordering at Siemens Industry Mall, Catalog CA 01, downloading and ordering catalogs

### Easy product selection and ordering: Industry Mall and Interactive Catalog CA 01

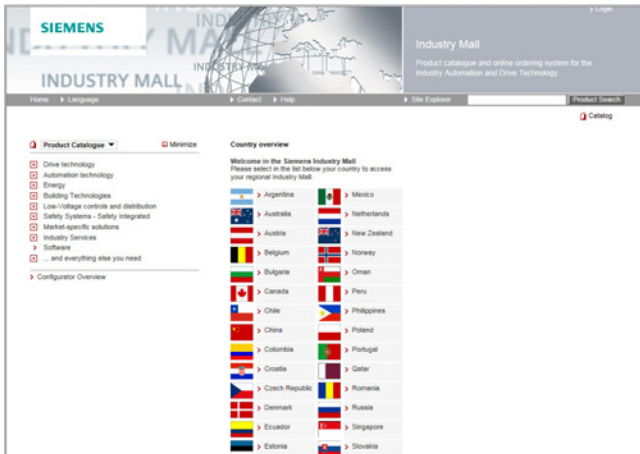

#### Industry Mall

The Industry Mall is a Siemens AG Internet ordering platform. It provides you with online access to a comprehensive product spectrum that is presented in an informative, well-organized way.

Powerful search functions help you select the required products, while configurators enable you to configure complex product and system components quickly and easily. CAx data are also available for you to use.

Data transfer allows the entire procedure, from selection through ordering to tracking and tracing, to be carried out online. Availability checks, individual customer discounting, and quotation preparation are also possible.

[www.siemens.com/industrymall](http://www.siemens.com/industrymall)



#### Interactive Catalog CA 01 – Products for automation and drives

The Interactive Catalog CA 01 combined with the Siemens Industry Mall unites the benefits of offline and online media in one application – the performance of an offline catalog with the availability of a wide range of up-to-date information on the Internet.

Select products and assemble orders using the CA 01, determine the availability of the selected products, and track and trace them via the Industry Mall.

Information and download:

[www.siemens.com/automation/ca01](http://www.siemens.com/automation/ca01)

### Downloading catalogs

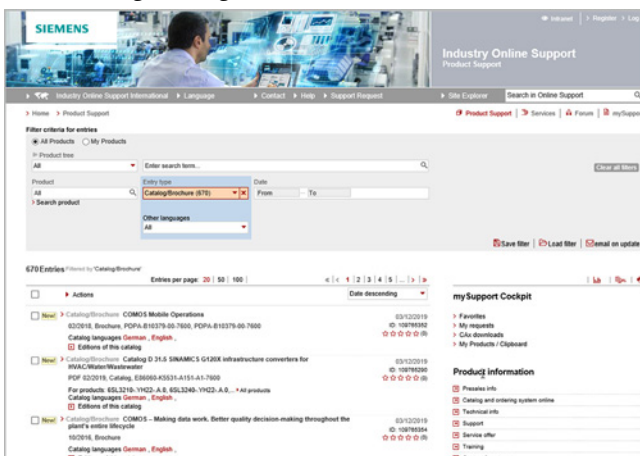

#### Siemens Industry Online Support

You can download catalogs and brochures in PDF format from Siemens Industry Online Support without having to register.

The filter box makes it possible to perform targeted searches.

[www.siemens.com/industry-catalogs](http://www.siemens.com/industry-catalogs)

### Ordering printed catalogs



Please contact your local Siemens branch if you are interested in ordering printed catalogs.

Addresses can be found at

[www.siemens.com/automation-contact](http://www.siemens.com/automation-contact)

## Get more information

SINAMICS S210 servo drive system:  
[www.siemens.com/sinamics-s210](http://www.siemens.com/sinamics-s210)

SIMOTICS electric motors:  
[www.siemens.com/simotics](http://www.siemens.com/simotics)

Motion Control Systems and Solutions  
for production machine and machine tool equipment:  
[www.siemens.com/motioncontrol](http://www.siemens.com/motioncontrol)

Local partners worldwide:  
[www.siemens.com/automation-contact](http://www.siemens.com/automation-contact)

Published by  
Siemens AG

Digital Industries  
Motion Control  
Postfach 31 80  
91050 Erlangen, Germany

For the U.S. published by  
Siemens Industry Inc.

100 Technology Drive  
Alpharetta, GA 30005  
United States

PDF (E86060-K5532-A101-A5-7600)  
V6.MKKATA.GMC.170  
KG 0120 RIF 112 En  
Produced in Germany  
© Siemens 2020

Subject to changes and errors. The information given in this document only contains general descriptions and/or performance features which may not always specifically reflect those described, or which may undergo modification in the course of further development of the products. The requested performance features are binding only when they are expressly agreed upon in the concluded contract.

All product designations may be trademarks or other rights of Siemens AG, its affiliated companies or other companies whose use by third parties for their own purposes could violate the rights of the respective owner.

## Security information

Siemens provides products and solutions with industrial security functions that support the secure operation of plants, systems, machines and networks.

In order to protect plants, systems, machines and networks against cyber threats, it is necessary to implement – and continuously maintain – a holistic, state-of-the-art industrial security concept. Siemens' products and solutions constitute one element of such a concept.

Customers are responsible for preventing unauthorized access to their plants, systems, machines and networks. Such systems, machines and components should only be connected to an enterprise network or the internet if and to the extent such a connection is necessary and only when appropriate security measures (e.g. firewalls and/or network segmentation) are in place.

For additional information on industrial security measures that may be implemented, please visit  
<https://www.siemens.com/industrialsecurity>

Siemens' products and solutions undergo continuous development to make them more secure. Siemens strongly recommends that product updates are applied as soon as they are available and that the latest product versions are used. Use of product versions that are no longer supported, and failure to apply the latest updates may increase customer's exposure to cyber threats.

To stay informed about product updates, subscribe to the Siemens Industrial Security RSS Feed under  
<https://www.siemens.com/industrialsecurity>